

BT152 Serial 16A SCRs

GENERAL DESCRIPTION:

High current density due to sing mesa technology. BT152 series of silicon controlled rectifiers are specifically designed for medium power switching and phase control applications. BT152 series are suitable for general purpose applications. a high gate sensitivity is required.

Main Features:

$I_T(RMS)$	VDRM/VRRM	VTM
16 A	600V and 800 V	≤ 1.75 V

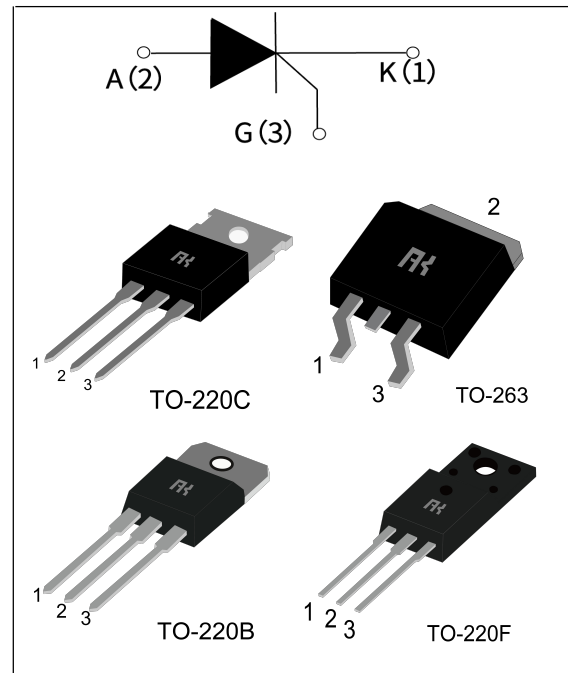

Absolute Ratings(limiting values) :

Symbol	Parameter	value	Unit	
$I_{T(RMS)}$	on-state RMS current(180°C conduction angle)	TO-220B/C Tc=110 C	16	A
		TO-220F Tc=90 C		
		TO-263 Tc=85 C		
I_{TSM}	Non repetitive surge peak on-state current (Tj= 25 °C)	tp= 8.3 ms	200	A
		tp = 10 ms	190	
V_{DRM}	Repetitive peak off-state voltage(Tj =25°C)	600 and 800	V	
V_{RRM}	Repetitive peak reverse voltage(Tj =25°C)	600 and 800	V	
T_{stg} T_j	Storage and operating junction temperature range	- 40 to + 150 - 40 to + 125	°C	
I^2t	I^2t value for fusing Tj = 125°C	tp = 10 ms	180	A ² s
di/dt	Critical rate of rise of on-state current $I_G=2I_{GT}$, tr \leq 100ns	50	A/ μ s	
I_{GM}	Peak gate current tp=20us Tj=125°C	4	A	
P_{GM}	Peak gate power tp=20us Tj=125°C	5	W	
$P_{G(av)}$	Average gate power dissipation Tj=125°C	1	W	

Electrical Characteristics :

Symbol	Test Condition	range	Value	Unit	
I_{GT}	$V_D=12V$ $R_L=3.3k\Omega$	$T_j=25^\circ C$	MAX	15	mA
V_{GT}		$T_j=25^\circ C$	MAX	1.5	V
V_{GD}	$V_D=V_{DRM}$ $R_L=3.3k\Omega$	$T_j=125^\circ C$	MIN	0.2	V
t_{gt}	$V_D=V_{DRM}$ $I_G=500mA$ $dIG/dt=0.2A/\mu s$	$T_j=25^\circ C$	TYP	2	μs
I_L	$V_D=12V$ $I_{GT}=0.1A$	$T_j=25^\circ C$	TYP	40	mA
I_H	$I_T=500mA$ gate open	$T_j=25^\circ C$	MAX	30	mA
V_{TM}	$I_{TM}=2*I_{T(RMS)}$ $tp=380\mu s$	$T_j=25^\circ C$	MAX	1.75	V
I_{DRM} I_{RRM}	$V_D=V_{DRM}, V_R=V_{RRM}$	$T_j=125^\circ C$	TYP	5	μA
		$T_j=125^\circ C$	MAX	2	mA
dV/dt	$V_D=67\%V_{DR}$ exponential waveform; $R_{GK}=100\Omega$	$T_j=125^\circ C$	TYP	500	$V/\mu s$

Thermal Resistances :

Symbol	Parameter	Value	Unit
$R_{th(j-c)}$	junction to mounting base	TO-220B/C	1.05
		TO-220F	2.2
		TO-263	2.5

FIG.1: Maximum power dissipation versus RMS on-state current

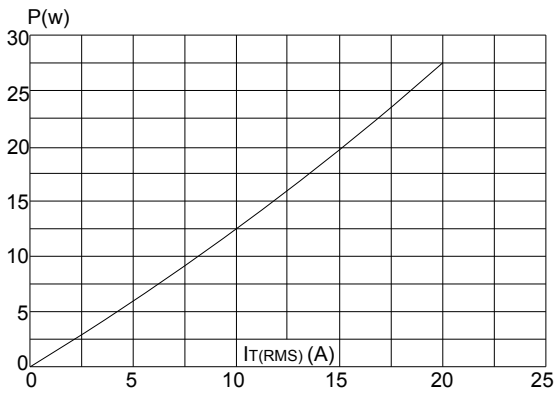

FIG.2: RMS on-state current versus case temperature

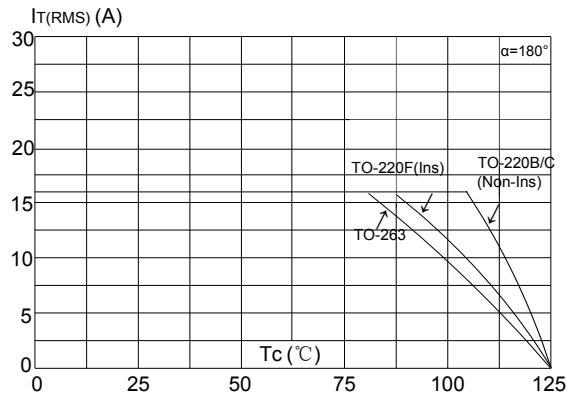

FIG.3: Surge peak on-state current versus number of cycles

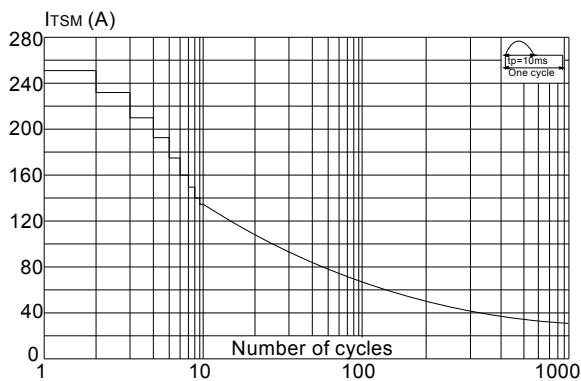

FIG.4: On-state characteristics (maximum values)

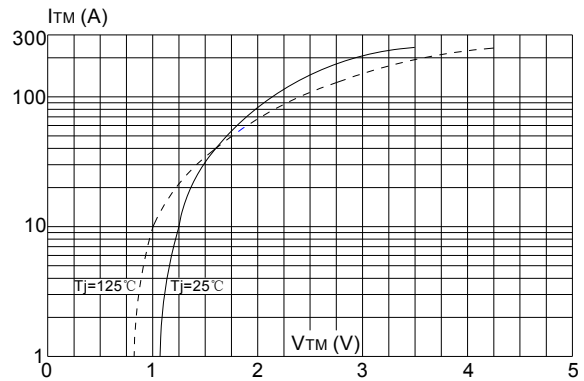

FIG.5: Non-repetitive surge peak on-state current for a sinusoidal pulse with width $t_p < 10\text{ms}$, and corresponding value of I^2t

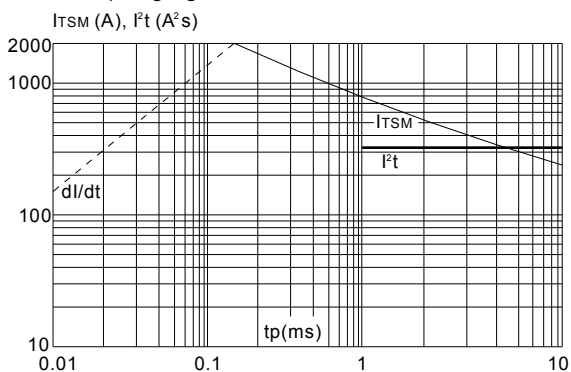
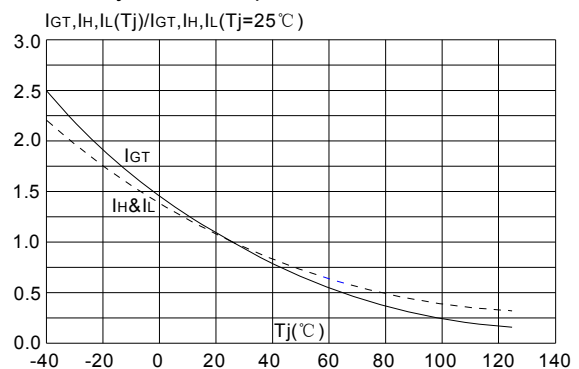
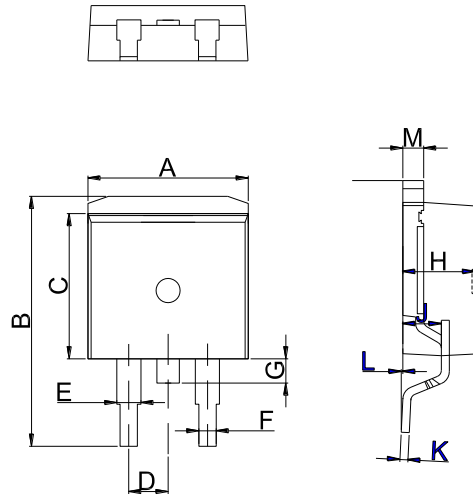

FIG.6: Relative variations of gate trigger current, holding current and latching current versus junction temperature



Package Mechanical Data :



TO-263

Ref.	Dimensions					
	Millimeters			Inches		
	Min.	Typ.	Max.	Min.	Typ.	Max.
A	9.90		10.20	0.390		0.402
B	14.70		15.80	0.579		0.622
C	9.4		9.6	0.37		0.378
D		2.54			0.100	
E	1.20		1.40	0.047		0.055
F	0.75		0.85	0.029		0.033
G			1.75			0.069
H	4.40		4.70	0.173		0.185
J	2.30		2.70	0.091		0.106
K	0.38		0.55	0.015		0.022
L	0	0.10	0.25	0	0.004	0.010
M	1.25		1.35	0.049		0.053

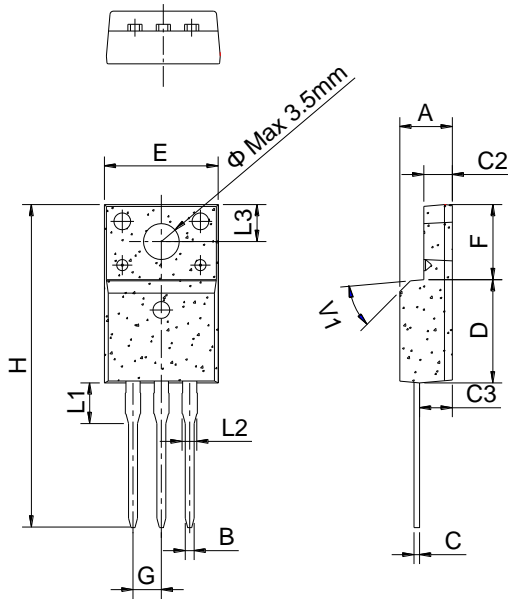

TO-220F Ins

Ref.	Dimensions					
	Millimeters			Inches		
	Min.	Typ.	Max.	Min.	Typ.	Max.
A	4.40		4.80	0.173		0.189
B	0.74	0.80	0.83	0.029	0.031	0.033
C	0.48		0.75	0.019		0.030
C2	2.40		2.70	0.094		0.106
C3	2.60		3.00	0.102		0.118
D	8.80		9.30	0.346		0.366
E	9.70		10.3	0.382		0.406
F	6.40		7.00	0.252		0.276
G		2.54			0.1	
H	28.0		29.8	1.102		1.173
L1		3.63			0.143	
L2	1.14		1.70	0.045		0.067
L3		3.30			0.130	
V1		45°			45°	

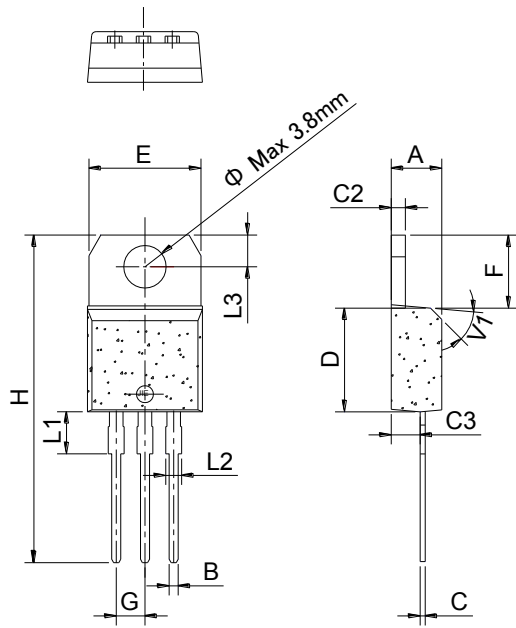

TO-220B

Ref.	Dimensions					
	Millimeters			Inches		
	Min.	Typ.	Max.	Min.	Typ.	Max.
A	4.40		4.60	0.173		0.181
B	0.61		0.88	0.024		0.035
C	0.46		0.70	0.018		0.028
C2	1.21		1.32	0.048		0.052
C3	2.40		2.72	0.094		0.107
D	8.60		9.70	0.339		0.382
E	9.60		10.4	0.378		0.409
F	6.20		6.60	0.244		0.260
G		2.54			0.1	
H	28.0		29.8	1.102		1.173
L1		3.75			0.148	
L2	1.14		1.70	0.045		0.067
L3	2.65		2.95	0.104		0.116
V1		45°			45°	

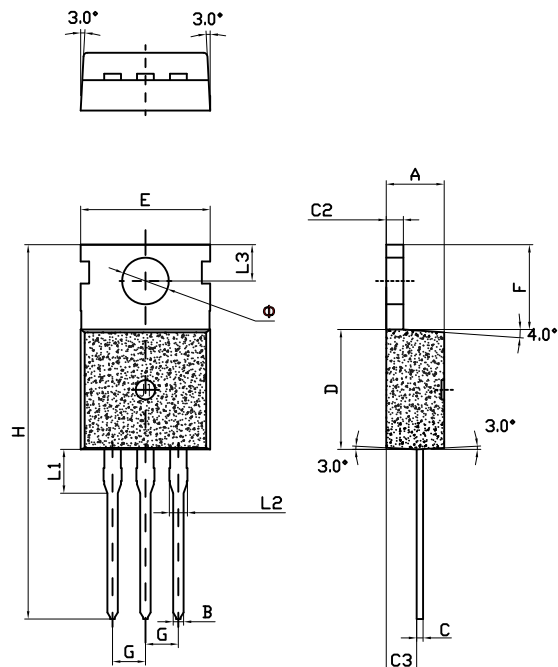

TO-220C

Ref.	Dimensions					
	Millimeters			Inches		
	Min.	Typ.	Max.	Min.	Typ.	Max.
A	4.4		4.6	0.173		1.181
B	0.7		0.9	0.027		0.035
C	0.45		0.6	0.018		0.024
C2	1.23		1.32	0.048		0.052
C3	2.2		2.6	0.086		0.102
D	8.9		9.9	0.350		0.390
E	9.9		10.3	0.390		0.406
F	6.3		6.9	0.248		0.272
G		2.54			0.1	
H	28.0		29.8	11.0		11.7
L1		3.2			0.126	
L2	1.14		1.7	0.045		0.067
L3	2.65		2.95	0.104		0.116
Φ		3.6			0.142	