

TN415 Serial 4ASCRs

GENERAL DESCRIPTION:

Glass passivated, sensitive gate thyristors in a plastic envelope, intended for use in general purpose switching and phase control applications. These devices are intended to be interfaced directly to microcontrollers, logic integrated circuits and other low power gate trigger circuits.

Main Features:

IT(RMS)	VDRM/VRRM	VTM
4 A	600V and 800 V	≤1.8 V

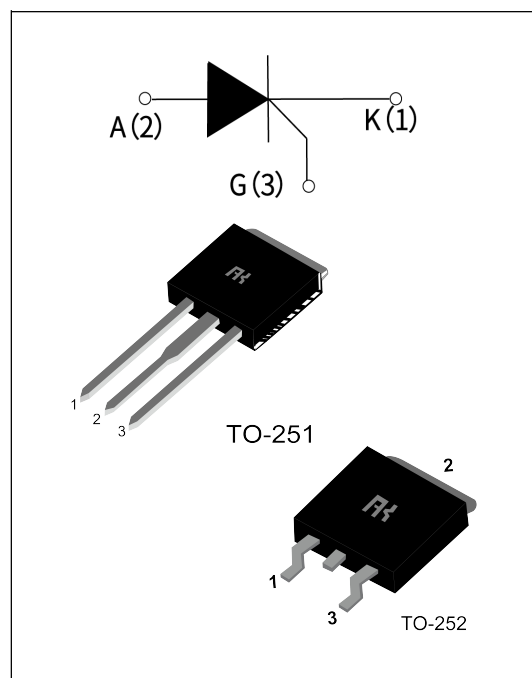

Absolute Ratings(limiting values) :

Symbol	Parameter		value	Unit
IT(RMS)	on-state RMS current(180°C conduction angle)		4	A
ITSM	Non repetitive surge peak on-state current (Tj= 25 °C)	tp= 8.3 ms	38	A
		tp = 10 ms	35	
VDRM	Repetitive peak off-state voltage(Tj =25°C)		600 and 800	V
VRRM	Repetitive peak reverse voltage(Tj =25°C)		600 and 800	V
Tstg Tj	Storage and operating junction temperature range		- 40 to + 150 - 40 to + 125	°C
I²t	I²t value for fusing Tj = 125°C	tp = 10 ms	6	A²s
di/dt	Critical rate of rise of on-state current IG=2xIGT, tr≤100ns		50	A/μs

Electrical Characteristics :

Symbol	Test Condition	range	Value	Unit	
I_{GT}	V _D =12V R _L =3.3kΩ	T _j =25°C	MAX	20	mA
V_{GT}		T _j =25°C	MAX	1.5	V
V_{GD}	V _D =V _{DRM} R _L =3.3kΩ	T _j =125°C	MIN	0.2	V
t_{gt}	V _D =V _{DRM} I _G = 500mA dI _G /dt = 0.2A/μs	T _j =25°C	TYP	2	μs
I_L	V _D =12V I _{GT} = 0.1 A	T _j =25°C	TYP	0.17	mA
I_H	I _T = 500mA gate open	T _j =25°C	MAX	6	mA
V_{TM}	I _{TM} = 2*I _{T (RMS)} tp=380μs	T _j =25°C	MAX	1.8	V
I_{DRM} I_{RRM}	V _D =V _{DRM} , V _R =V _{RRM}	T _j =125°C	TYP	0.1	mA
		T _j =125°C	MAX	0.5	mA
dV_D/dt	V _D =67%V _{DR} exponential waveform; R _{GK} = 100 Ω	T _j =125°C	TYP	50	V/μs

Thermal Resistances :

Symbol	Parameter		Value	Unit
R_{th (j-c)}	junction to mounting case	TO-251/252	2.5	°C/W
R_{th (j-a)}	Junction to ambient	TO-251/252	60	K/W

Fig.1: Maximum average power dissipation versus average on-state current .

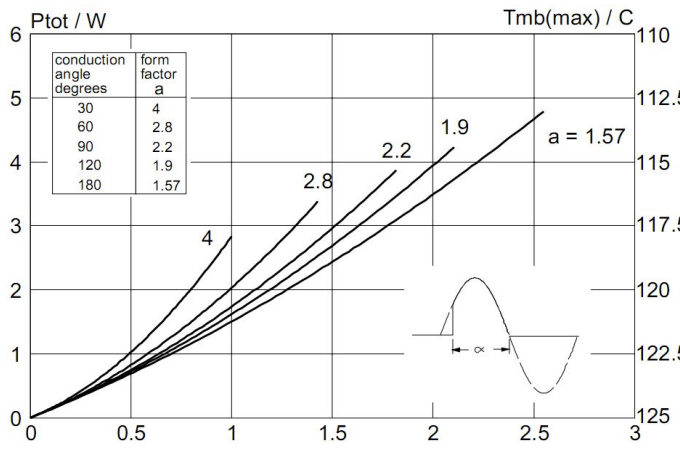

Fig.2 : Maximum permissible non-repetitive peak on-state current ITSM, versus pulse width tp, for sinusoidal currents, tp ≤ 10ms

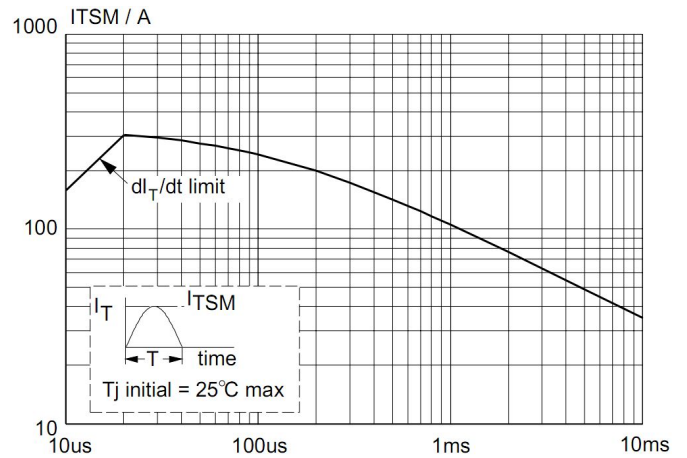

Fig.3 : Typical and maximum on-state characteristic.

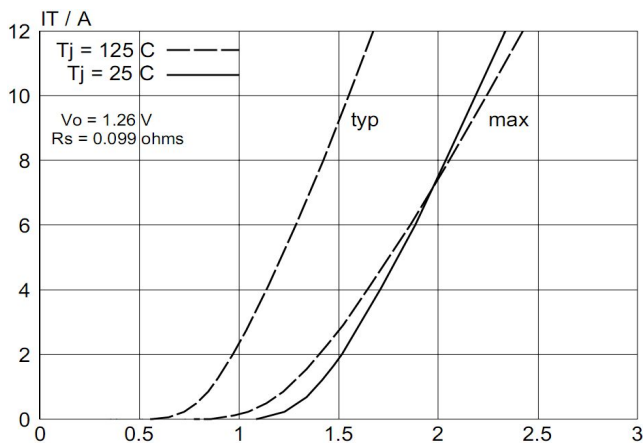

Fig.4 : Maximum permissible RMS current IT(RMS) , versus mounting base temperature Tmb.

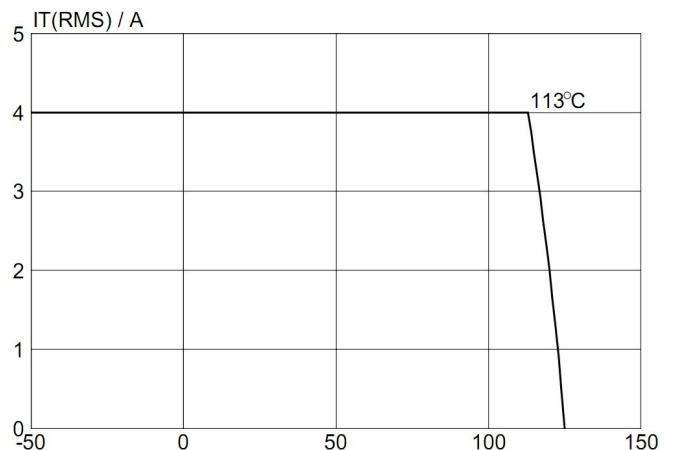

Fig.5 : Maximum permissible repetitive rms on-state current IT(RMS), versus surge duration, for sinusoidal currents, f = 50 Hz; Tmb ≤ 113°C

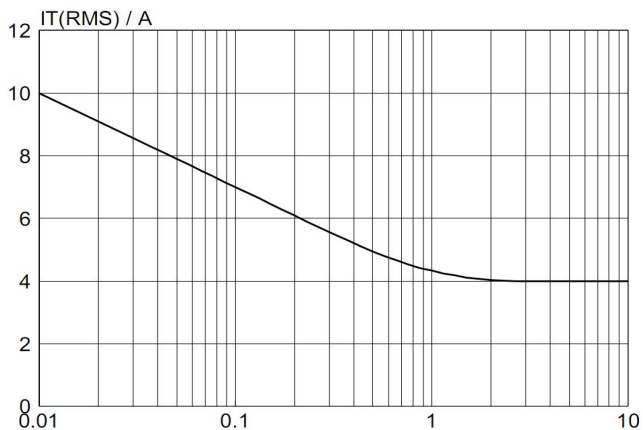

Fig.6: Normalised gate trigger voltage VGT(Tj)/ VGT(25 ° C), versus junction temperature Tj

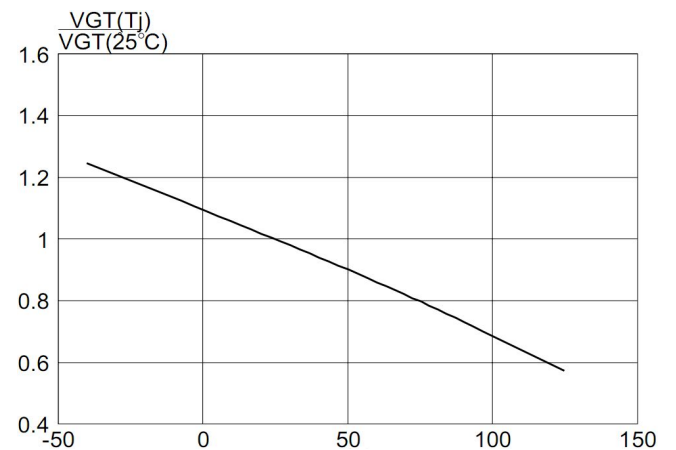

Fig.7 : Typical, critical rate of rise of off-state voltage, dV_D/dt versus junction temperature T_j

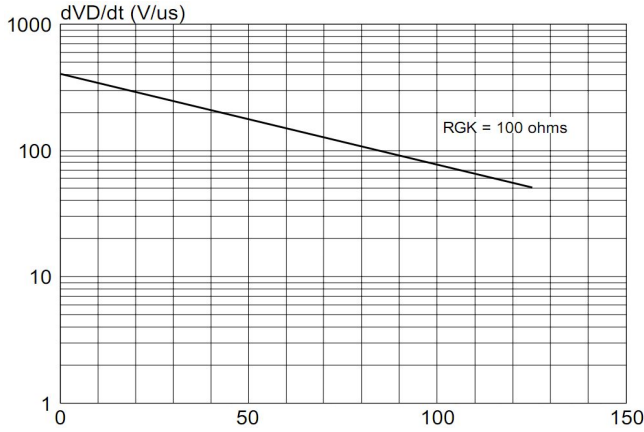
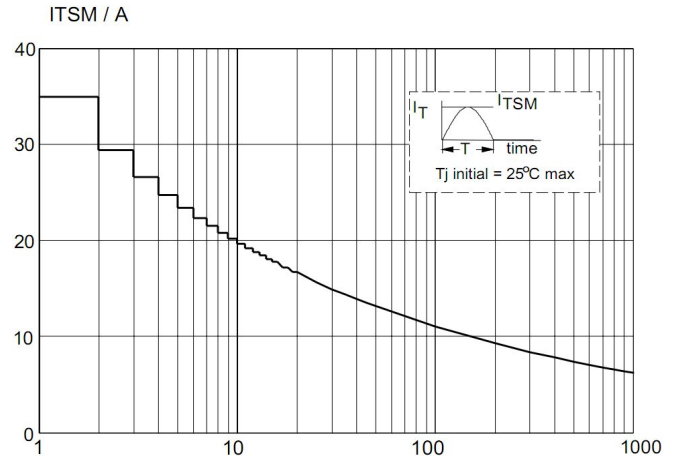
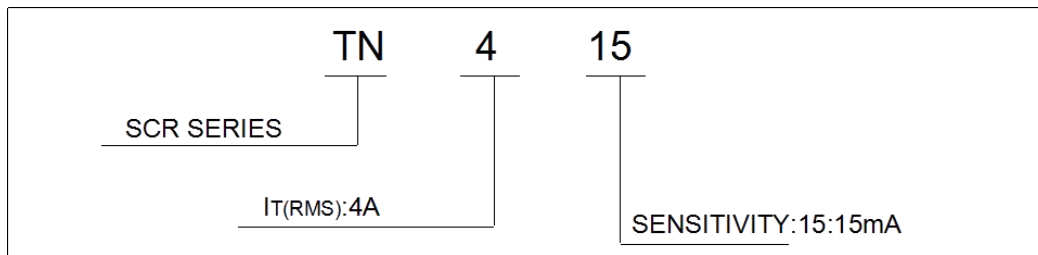

Fig.6: Non repetitive surge peak on-state current versus number of cycles.



Ordering Information



Package Mechanical Data :

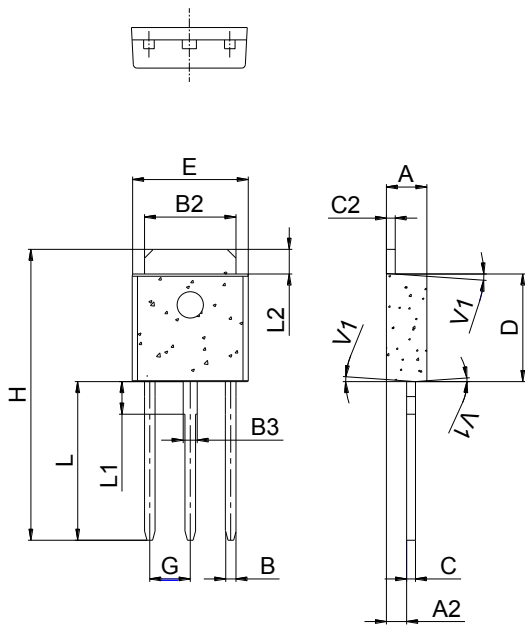

TO-251

Ref.	Dimensions					
	Millimeters			Inches		
	Min.	Typ.	Max.	Min.	Typ.	Max.
A	2.20		2.40	0.086		0.095
A2	0.90		1.20	0.035		0.047
B	0.55		0.65	0.022		0.026
B2	5.10		5.40	0.200		0.213
B3	0.76		0.85	0.030		0.033
C	0.45		0.62	0.018		0.024
C2	0.48		0.62	0.019		0.024
D	6.00		6.20	0.236		0.244
E	6.40		6.70	0.252		0.264
G		2.30			0.091	
H	16.0		17.0	0.630		0.669
L	8.90		9.40	0.350		0.370
L1	1.80		1.90	0.071		0.075
L2	1.37		1.50	0.054		0.059
V1		4°			4°	

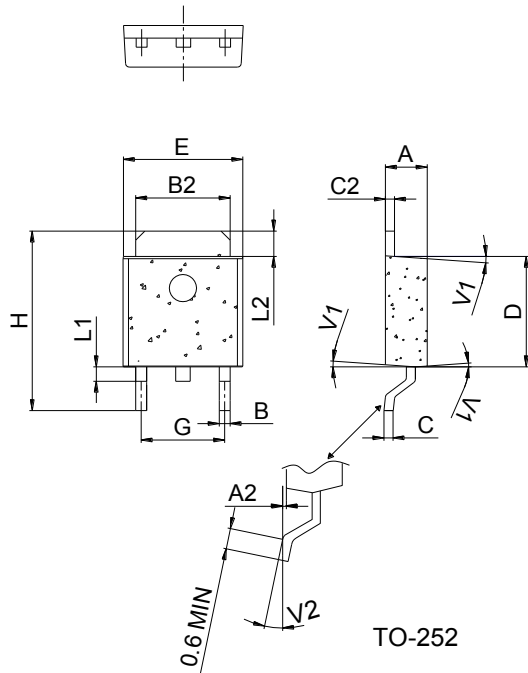

Ref.	Dimensions					
	Millimeters			Inches		
	Min.	Typ.	Max.	Min.	Typ.	Max.
A	2.20		2.40	0.086		0.095
A2	0.03		0.23	0.001		0.009
B	0.55		0.65	0.022		0.026
B2	5.10		5.40	0.200		0.213
C	0.45		0.62	0.018		0.024
C2	0.48		0.62	0.019		0.024
D	6.00		6.20	0.236		0.244
E	6.40		6.70	0.252		0.264
G	4.40		4.70	0.173		0.185
H	9.35		10.6	0.368		0.417
L1	1.30		1.70	0.051		0.067
L2	1.37		1.50	0.054		0.059
V1		4°			4°	
V2		0°	8°		0°	8°

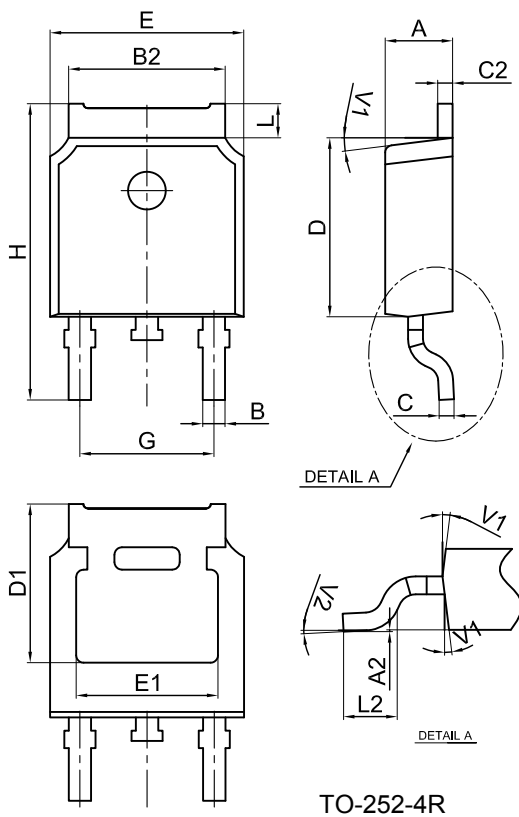

Ref.	Dimensions					
	Millimeters			Inches		
	Min.	Typ.	Max.	Min.	Typ.	Max.
A	2.10		2.50	0.083		0.098
A2	0		0.10	0		0.004
B	0.66		0.86	0.026		0.034
B2	5.18		5.48	0.202		0.216
C	0.40		0.60	0.016		0.024
C2	0.44		0.58	0.017		0.023
D	5.90		6.30	0.232		0.248
D1	5.30REF			0.209REF		
E	6.40		6.80	0.252		0.268
E1	4.63			0.182		
G	4.47		4.67	0.176		0.184
H	9.50		10.70	0.374		0.421
L	1.09		1.21	0.043		0.048
L2	1.35		1.65	0.053		0.065
V1		7°			7°	
V2		0°	6°		0°	6°