

## TN815 Serial 8A SCRs

### GENERAL DESCRIPTION :

High current density due to single mese technology. TN815 series of silicon controlled rectifiers are specifically designed for medium power switching and phase control applications. TN815 series are suitable for general purpose applications where a high gate sensitivity is required.

### Main Features:

IT(RMS)	VDRM/VRRM	VTM
8 A	600V and 800 V	≤1.6 V

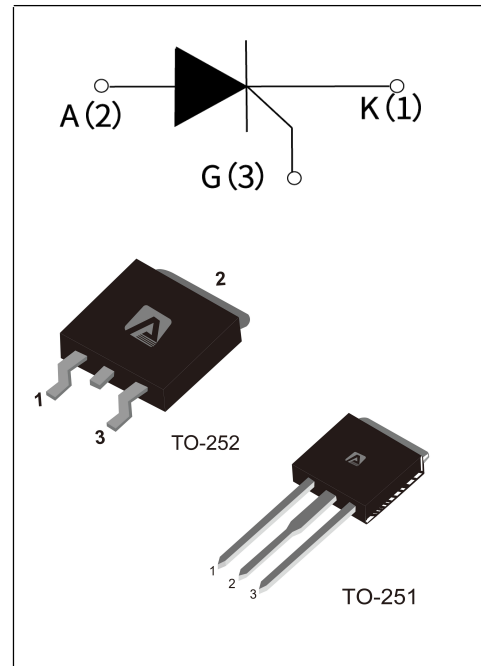

### Absolute Ratings(limiting values) :

Symbol	Parameter		value	Unit
$I_{T(RMS)}$	on-state RMS current(180°C conduction angle)		8	A
$I_{TSM}$	Non repetitive surge peak on-state current ( $T_j = 25\text{ }^\circ\text{C}$ )	$t_p = 8.3\text{ ms}$	73	A
		$t_p = 10\text{ ms}$	70	
$V_{DRM}$	Repetitive peak off-state voltage( $T_j = 25\text{ }^\circ\text{C}$ )		600 and 800	V
$V_{RRM}$	Repetitive peak reverse voltage( $T_j = 25\text{ }^\circ\text{C}$ )		600 and 800	V
$T_{stg}$ $T_j$	Storage and operating junction temperature range		- 40 to + 150 - 40 to + 125	$^\circ\text{C}$
$I^2t$	$I^2t$ value for fusing $T_j = 125\text{ }^\circ\text{C}$	$t_p = 10\text{ ms}$	25	$\text{A}^2\text{s}$
$di/dt$	Critical rate of rise of on-state current $I_G = 2 \times I_{GT}$ , $t_r \leq 100\text{ ns}$		50	$\text{A}/\mu\text{s}$

**Electrical Characteristics :**

Symbol	Test Condition	range	Value	Unit	
<b>I<sub>GT</sub></b>	V <sub>D</sub> =12V    R <sub>L</sub> =3.3kΩ	T <sub>j</sub> =25°C	MAX	15	mA
<b>V<sub>GT</sub></b>		T <sub>j</sub> =25°C	MAX	1.3	V
<b>V<sub>GD</sub></b>	V <sub>D</sub> =V <sub>DRM</sub> R <sub>L</sub> =3.3kΩ	T <sub>j</sub> =125°C	MIN	0.2	V
<b>t<sub>gt</sub></b>	V <sub>D</sub> =V <sub>DRM</sub> I <sub>G</sub> = 500mA    dI <sub>G</sub> /dt = 0.2A/μs	T <sub>j</sub> =25°C	TYP	2	μs
<b>I<sub>L</sub></b>	V <sub>D</sub> =12V    I <sub>GT</sub> = 0.1 A	T <sub>j</sub> =25°C	TYP	50	mA
<b>I<sub>H</sub></b>	I <sub>T</sub> = 500mA gate open	T <sub>j</sub> =25°C	MAX	40	mA
<b>V<sub>TM</sub></b>	I <sub>TM</sub> = 2*I <sub>T (RMS)</sub> tp=380μs	T <sub>j</sub> =25°C	MAX	1.6	V
<b>I<sub>DRM</sub></b> <b>I<sub>RRM</sub></b>	V <sub>D</sub> =V <sub>DRM</sub> , V <sub>R</sub> =V <sub>RRM</sub>	T <sub>j</sub> =125°C	TYP	5	μA
		T <sub>j</sub> =125°C	MAX	2	mA
<b>dV<sub>D</sub>/dt</b>	V <sub>D</sub> =67%V <sub>DR</sub> exponential waveform; R <sub>GK</sub> = 100 Ω	T <sub>j</sub> =125°C	TYP	150	V/μs

**Thermal Resistances :**

Symbol	Parameter		Value	Unit
<b>R<sub>th (j-c)</sub></b>	junction to mounting base	TO-251/252	2.5	°C/W
<b>R<sub>th (j-a)</sub></b>	Junction to ambient	TO-251/252	60	°C/W

Fig.1: Maximum average power dissipation versus average on-state current .

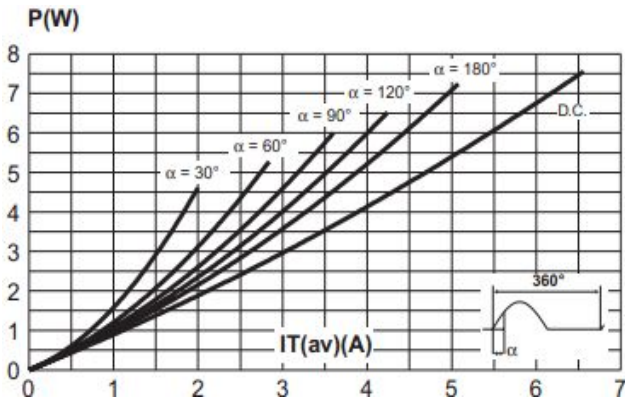

Fig.2 : Correlation between maximum average power dissipation and maximum allowable temperatures (Tamb and Tcase) for different thermal resistances heat sink+contact.

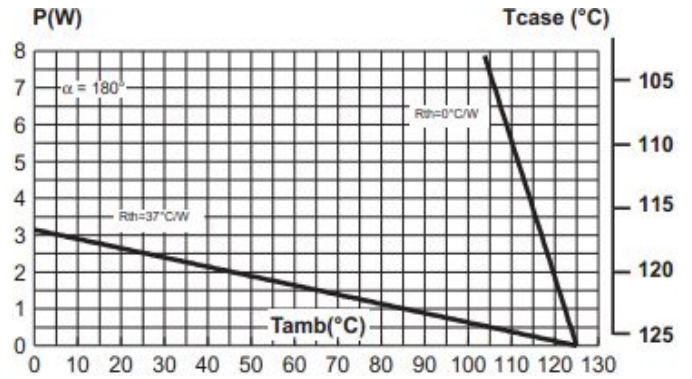

Fig.3 : Average and D.C. on-state current versus case temperature.

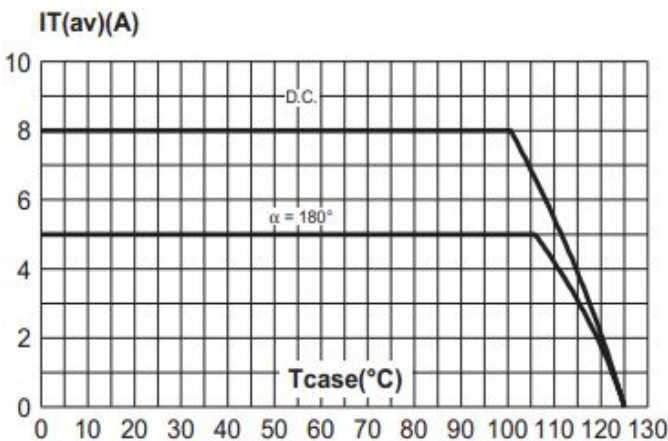

Fig.4 : Average and D.C. on-state current versus case temperature.

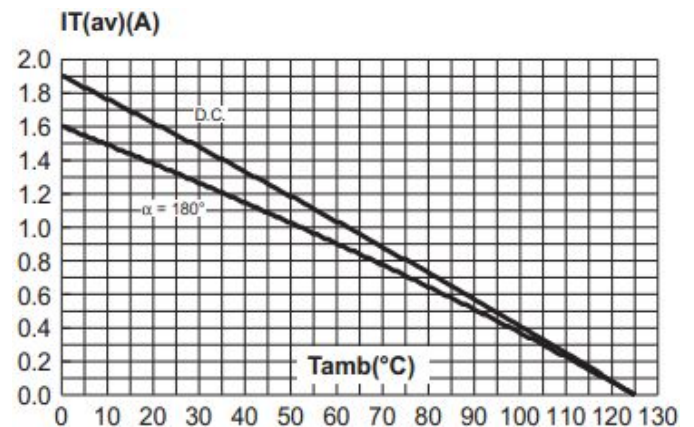

Fig.5 : Relative variation of thermal impedance versus pulse duration.

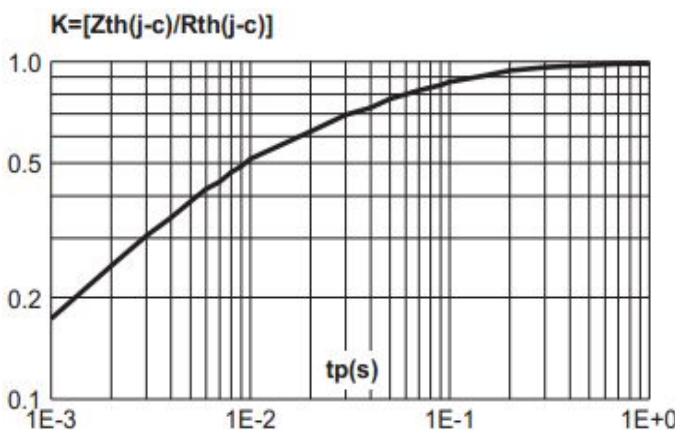

Fig.6 : Relative variation of thermal impedance versus pulse duration.

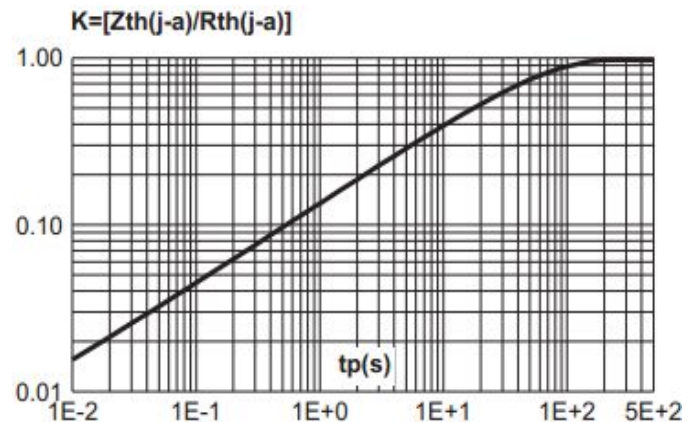

Fig.7 : Relative variation of gate trigger current and holding current versus junction temperature.

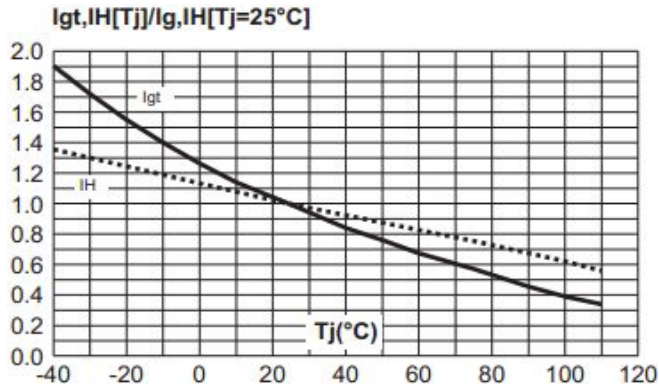
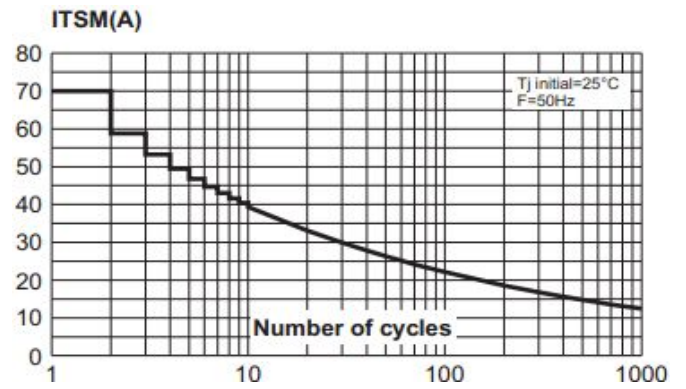
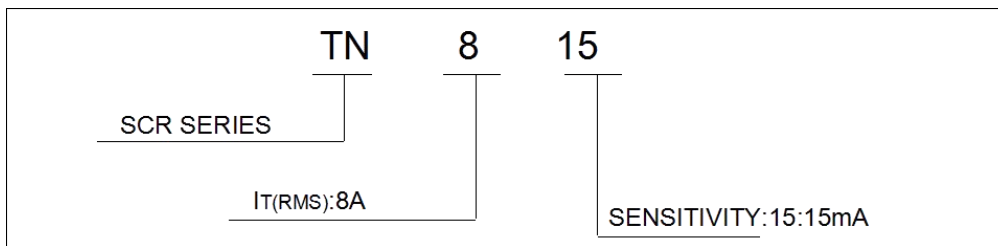

Fig.6: Non repetitive surge peak on-state current versus number of cycles.



**Ordering Information**



**Package Mechanical Data :**

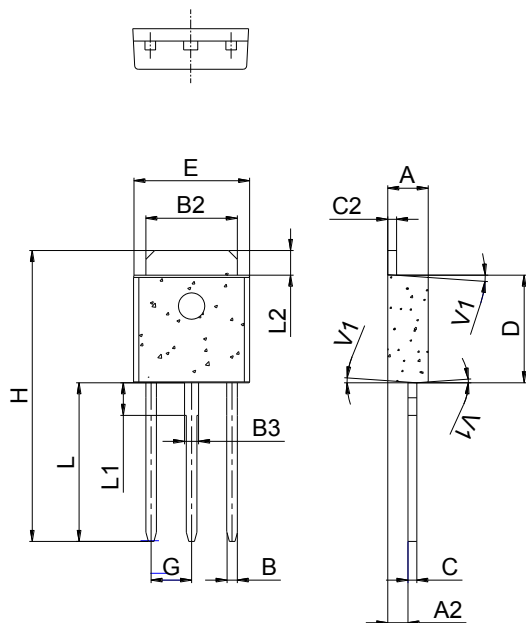

TO-251

Ref.	Dimensions					
	Millimeters			Inches		
	Min.	Typ.	Max.	Min.	Typ.	Max.
A	2.20		2.40	0.086		0.095
A2	0.90		1.20	0.035		0.047
B	0.55		0.65	0.022		0.026
B2	5.10		5.40	0.200		0.213
B3	0.76		0.85	0.030		0.033
C	0.45		0.62	0.018		0.024
C2	0.48		0.62	0.019		0.024
D	6.00		6.20	0.236		0.244
E	6.40		6.70	0.252		0.264
G		2.30			0.091	
H	16.0		17.0	0.630		0.669
L	8.90		9.40	0.350		0.370
L1	1.80		1.90	0.071		0.075
L2	1.37		1.50	0.054		0.059
V1		4°			4°	

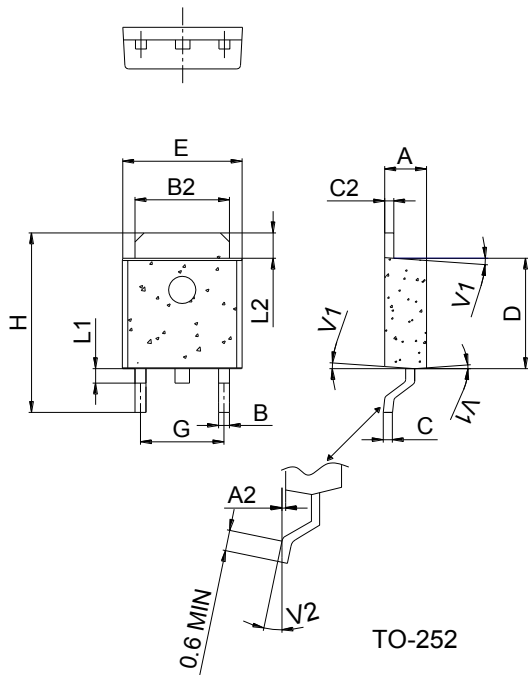

Ref.	Dimensions					
	Millimeters			Inches		
	Min.	Typ.	Max.	Min.	Typ.	Max.
A	2.20		2.40	0.086		0.095
A2	0.03		0.23	0.001		0.009
B	0.55		0.65	0.022		0.026
B2	5.10		5.40	0.200		0.213
C	0.45		0.62	0.018		0.024
C2	0.48		0.62	0.019		0.024
D	6.00		6.20	0.236		0.244
E	6.40		6.70	0.252		0.264
G	4.40		4.70	0.173		0.185
H	9.35		10.6	0.368		0.417
L1	1.30		1.70	0.051		0.067
L2	1.37		1.50	0.054		0.059
V1		4°			4°	
V2		0°	8°		0°	8°

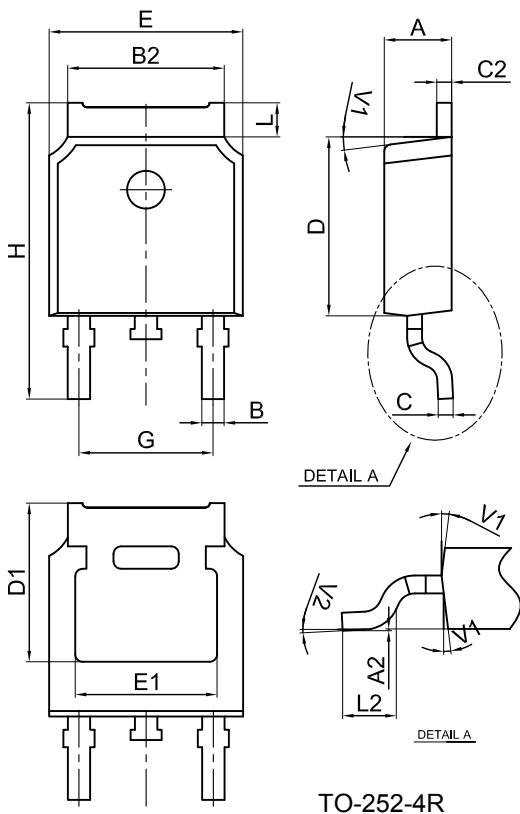

Ref.	Dimensions					
	Millimeters			Inches		
	Min.	Typ.	Max.	Min.	Typ.	Max.
A	2.10		2.50	0.083		0.098
A2	0		0.10	0		0.004
B	0.66		0.86	0.026		0.034
B2	5.18		5.48	0.202		0.216
C	0.40		0.60	0.016		0.024
C2	0.44		0.58	0.017		0.023
D	5.90		6.30	0.232		0.248
D1	5.30REF			0.209REF		
E	6.40		6.80	0.252		0.268
E1	4.63			0.182		
G	4.47		4.67	0.176		0.184
H	9.50		10.70	0.374		0.421
L	1.09		1.21	0.043		0.048
L2	1.35		1.65	0.053		0.065
V1		7°			7°	
V2		0°	6°		0°	6°