

TN1215 Serial 12A SCRs

GENERAL DESCRIPTION:

High current density due to singel mesa technology. TN1215 series of silicon controlled rectifiers are specifically designed for medium power switching and phase control applications. TN1215 series are suitable for general purpose applications where a high gate sensitivity is required.

Main Features:

$I_{T(RMS)}$	VDRM/VRRM	V_{TM}
12 A	600V and 800 V	≤1.7 V

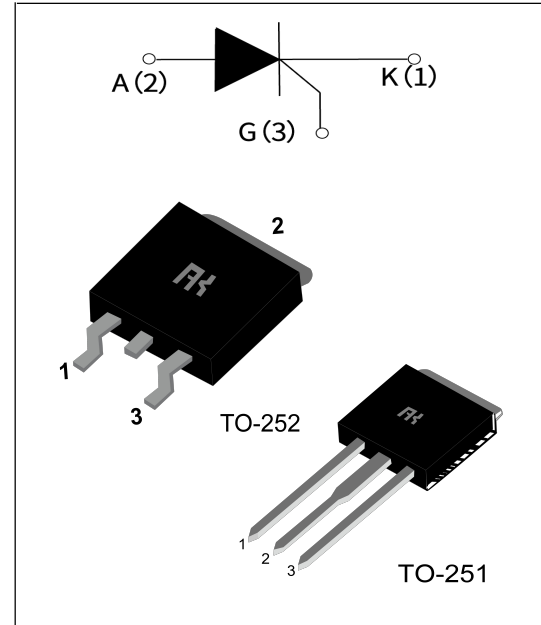

Absolute Ratings(limiting values) :

Symbol	Parameter		value	Unit
$I_{T(RMS)}$	on-state RMS current(180°C conduction angle)		12	A
I_{TSM}	Non repetitive surge peak on-state current ($T_j = 25^\circ\text{C}$)	$t_p = 8.3\text{ ms}$	110	A
		$t_p = 10\text{ ms}$	100	
V_{DRM}	Repetitive peak off-state voltage($T_j = 25^\circ\text{C}$)		600 and 800	V
V_{RRM}	Repetitive peak reverse voltage($T_j = 25^\circ\text{C}$)		600 and 800	V
T_{stg} T_j	Storage and operating junction temperature range		- 40 to + 150 - 40 to + 125	°C
I^2t	I^2t value for fusing $T_j = 125^\circ\text{C}$	$t_p = 10\text{ ms}$	50	A^2s
di/dt	Critical rate of rise of on-state current $I_G = 2 \times I_{GT}$, $t_r \leq 100\text{ns}$		50	$\text{A}/\mu\text{s}$
I_{GM}	Peak gate current $t_p = 20\mu\text{s}$ $T_j = 125^\circ\text{C}$		2	A
P_{GM}	Peak gate power $t_p = 20\mu\text{s}$ $T_j = 125^\circ\text{C}$		5	W
$P_{G(av)}$	Average gate power dissipation $T_j = 125^\circ\text{C}$		0.5	W

Electrical Characteristics :

Symbol	Test Condition	range	Value	Unit	
I_{GT}	V _D =12V R _L =3.3kΩ	T _j =25°C	MAX	15	mA
V_{GT}		T _j =25°C	MAX	1.5	V
V_{GD}	V _D =V _{DRM} R _L =3.3kΩ	T _j =125°C	MIN	0.2	V
t_{gt}	V _D =V _{DRM} I _G = 500mA dI _G /dt = 0.2A/μs	T _j =25°C	TYP	2	μs
I_L	V _D =12V I _{GT} = 0.1 A	T _j =25°C	TYP	40	mA
I_H	I _T = 500mA gate open	T _j =25°C	MAX	30	mA
V_{TM}	I _{TM} = 2*I _{T (RMS)} tp=380μs	T _j =25°C	MAX	1.7	V
I_{DRM} I_{RRM}	V _D =V _{DRM} , V _R =V _{RRM}	T _j =125°C	TYP	10	μA
		T _j =125°C	MAX	0.5	mA
dV_D/dt	V _D =67%V _{DR} exponential waveform; R _{GK} = 100 Ω	T _j =125°C	TYP	200	V/μs

Thermal Resistances :

Symbol	Parameter		Value	Unit
R_{th (j-mb)}	Thermal resistance from junction to mounting case	TO-252\251	2.0	°C/W

FIG.1 Maximum power dissipation versus RMS on-state current

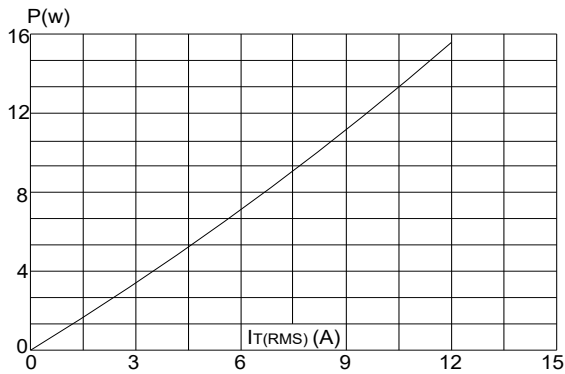

FIG.2: RMS on-state current versus case temperature

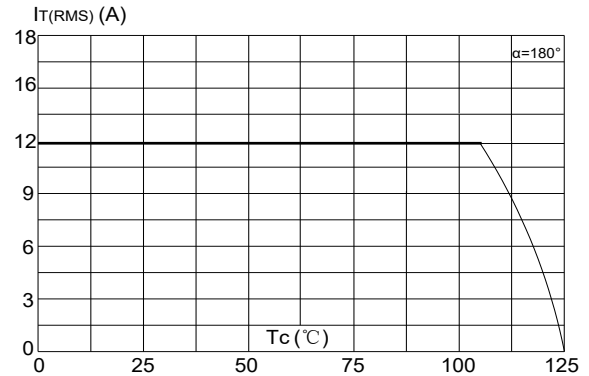

FIG.3: Surge peak on-state current versus number of cycles

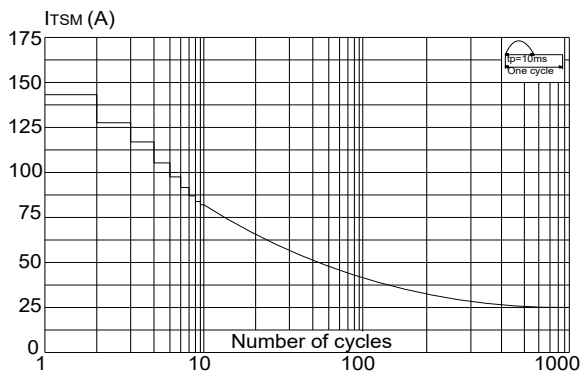

FIG.4: On-state characteristics (maximum values)

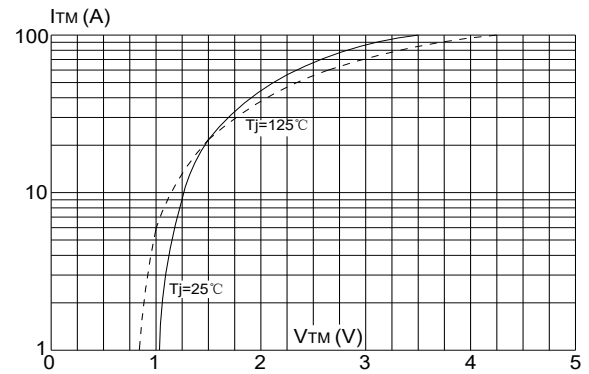

FIG.5: Non-repetitive surge peak on-state current for a sinusoidal pulse with width $t_p < 10\text{ms}$, and corresponding value of I^2t ($dI/dt < 50\text{A}/\mu\text{s}$)

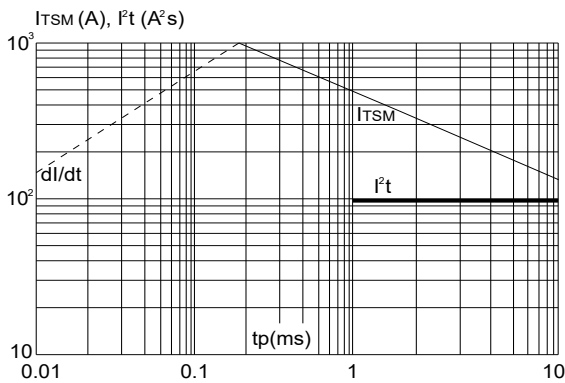
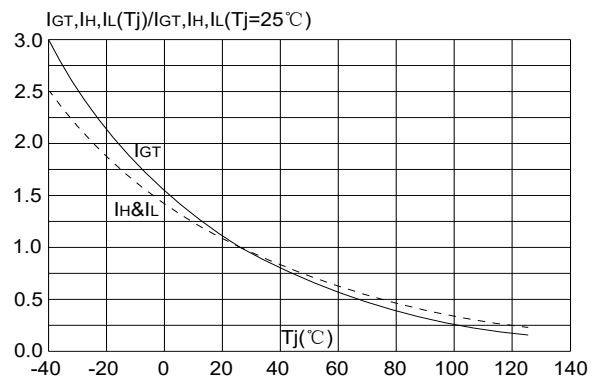
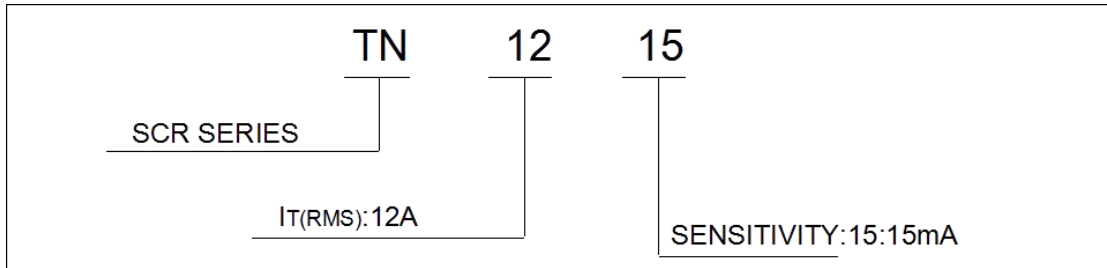

FIG.6: Relative variations of gate trigger current, holding current and latching current versus junction temperature



Ordering Information



Package Mechanical Data :

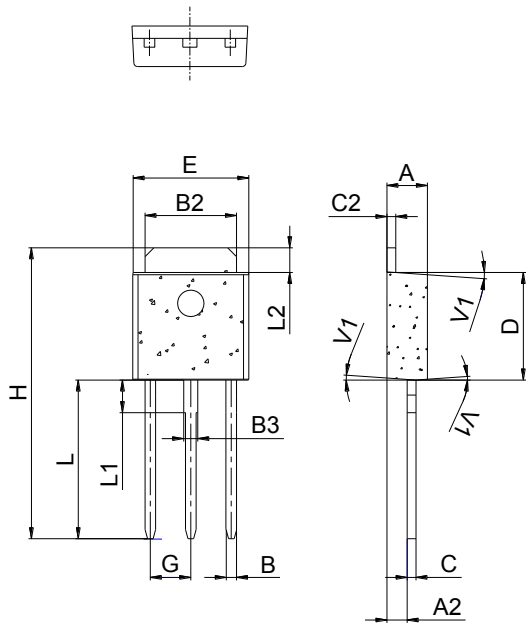

TO-251

Ref.	Dimensions					
	Millimeters			Inches		
	Min.	Typ.	Max.	Min.	Typ.	Max.
A	2.20		2.40	0.086		0.095
A2	0.90		1.20	0.035		0.047
B	0.55		0.65	0.022		0.026
B2	5.10		5.40	0.200		0.213
B3	0.76		0.85	0.030		0.033
C	0.45		0.62	0.018		0.024
C2	0.48		0.62	0.019		0.024
D	6.00		6.20	0.236		0.244
E	6.40		6.70	0.252		0.264
G		2.30			0.091	
H	16.0		17.0	0.630		0.669
L	8.90		9.40	0.350		0.370
L1	1.80		1.90	0.071		0.075
L2	1.37		1.50	0.054		0.059
V1		4°			4°	

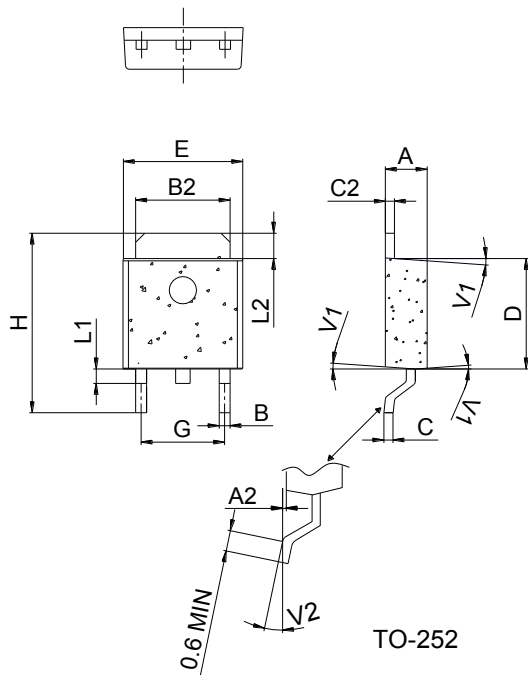

Ref.	Dimensions					
	Millimeters			Inches		
	Min.	Typ.	Max.	Min.	Typ.	Max.
A	2.20		2.40	0.086		0.095
A2	0.03		0.23	0.001		0.009
B	0.55		0.65	0.022		0.026
B2	5.10		5.40	0.200		0.213
C	0.45		0.62	0.018		0.024
C2	0.48		0.62	0.019		0.024
D	6.00		6.20	0.236		0.244
E	6.40		6.70	0.252		0.264
G	4.40		4.70	0.173		0.185
H	9.35		10.6	0.368		0.417
L1	1.30		1.70	0.051		0.067
L2	1.37		1.50	0.054		0.059
V1		4°			4°	
V2		0°	8°		0°	8°

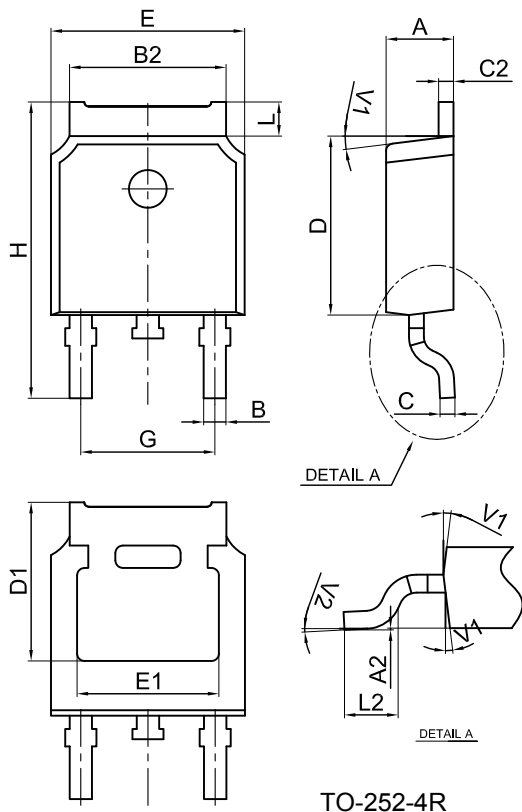

Ref.	Dimensions					
	Millimeters			Inches		
	Min.	Typ.	Max.	Min.	Typ.	Max.
A	2.10		2.50	0.083		0.098
A2	0		0.10	0		0.004
B	0.66		0.86	0.026		0.034
B2	5.18		5.48	0.202		0.216
C	0.40		0.60	0.016		0.024
C2	0.44		0.58	0.017		0.023
D	5.90		6.30	0.232		0.248
D1	5.30REF			0.209REF		
E	6.40		6.80	0.252		0.268
E1	4.63			0.182		
G	4.47		4.67	0.176		0.184
H	9.50		10.70	0.374		0.421
L	1.09		1.21	0.043		0.048
L2	1.35		1.65	0.053		0.065
V1		7°			7°	
V2		0°	6°		0°	6°