

## 600V Isolation FRD Module

### Description

The Fast Recovery Diode module devices are optimized to reduce losses and EMI/RFI in high frequency power conditioning electrical systems.

The Fast Recovery Diode module is ideally suited for power converters, inverter welders, motor drives and other applications where switching losses are significant portion of the total losses.

### Features

- Repetitive Reverse Voltage:  $V_{RRM} = 600V$
- Low Forward Voltage:  $V_F(\text{typ.}) = 1.3V @ I_F=150A$
- Average Forward Current:  $I_{F(AV)} = 150A @ T_C=100^\circ C$
- Reverse Recovery Time:  $t_{rr}(\text{typ.}) = 100ns$
- Extensive Characterization of Recovery Parameters
- Reduced EMI and RFI
- Isolation Type Package
- $150^\circ C$  Operating Junction Temperature
- Built-in Dual FRD Construction

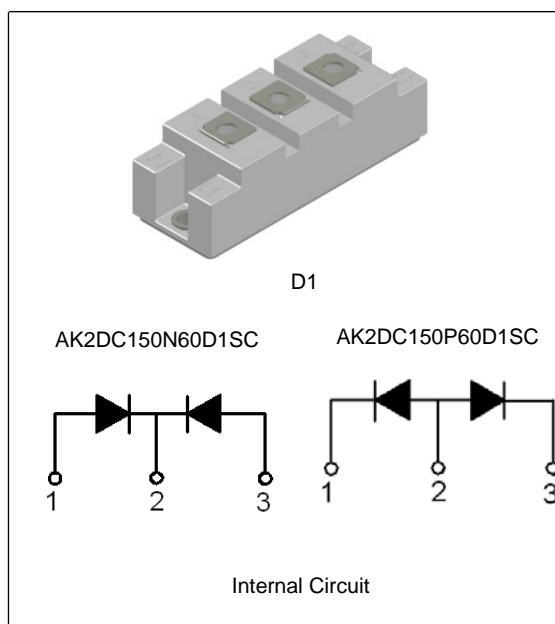

### Applications

- High Speed & High Power converters, Inverter Welders
- Various Switching and Telecommunication Power Supply

### Absolute Maximum Ratings ( $T_C=25^\circ C$ , unless otherwise noted)

Symbol	Parameter		Ratings	Unit	
$V_{RRM}$	Repetitive Peak Reverse Voltage		600	V	
$V_R$	DC Blocking Voltage		480	V	
$I_{F(AV)}$	Average Rectified Forward Current	Per Diode	$T_C = 25^\circ C$	300	A
			$T_C = 100^\circ C$	150	
		Per Package	$T_C = 25^\circ C$	600	
			$T_C = 100^\circ C$	300	
$I_{FSM}$	Non-repetitive Peak Surge Current (Per Diode) 60Hz Single Half-sine Wave		2750	A	
$I^2t$	$I^2t$ For Fusing 60Hz Sine Wave		$31.4 * 10^3$	$A^2S$	
$P_D$	Maximum Power Dissipation		550	W	
$V_{iso}$	Isolation Voltage @AC 1 Minutes		3300	V	
$T_J$	Junction Temperature		-55 ~ +150	$^\circ C$	
$T_{STG}$	Storage Temperature Range		-55 ~ +150	$^\circ C$	
	Mounting Torque (M5)		4.0	N.m	
	Terminal Torque (M5)		3.0	N.m	
	Weight		145	g	

**Electrical Characteristics** (Per Diode,  $T_C=25\text{ }^\circ\text{C}$ , unless otherwise noted)

Symbol	Parameter	Conditions	Min.	Typ.	Max.	Unit
$V_F$	Forward Voltage Drop	$I_F=150\text{A}$	-	1.3	1.8	V
		$I_F=150\text{A}$ , $T_C=100\text{ }^\circ\text{C}$	-	1.15	-	V
$I_{RM}$	Reverse Leakage Current	$V_R=600\text{V}$	-	-	0.5	mA
		$V_R=600\text{V}$ , $T_C=100\text{ }^\circ\text{C}$	-	-	1	mA
$t_{rr}$	Reverse Recovery Time	$I_F=1\text{A}$ , $di/dt=-200\text{A/us}$	-	35	-	ns
$t_{rr}$	Reverse Recovery Time	$I_F=150\text{A}$ , $di/dt=-200\text{A/us}$	-	100	130	ns
$I_{rr}$	Reverse Recovery Current		-	12.0	-	A
$t_{rr}$	Reverse Recovery Time	$I_F=150\text{A}$ , $di/dt=-200\text{A/us}$ , $T_C=100\text{ }^\circ\text{C}$	-	270	-	ns
$I_{rr}$	Reverse Recovery Current		-	23.5	-	A

**Thermal Characteristics**

Symbol	Parameter	Ratings	Unit
$R_{th(J-C)}$	Thermal Resistance, Junction to case	0.23	$^\circ\text{C/W}$

**Typical Performance Characteristics**

Fig. 1. Typical Characteristics:  $V_F$  vs.  $I_F$

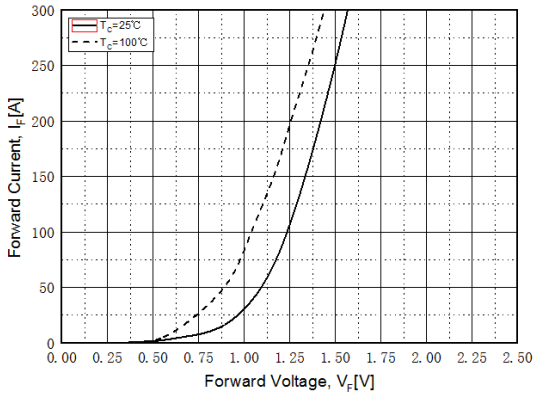

Fig. 2. Typical Reverse Recovery Time vs.  $di/dt$

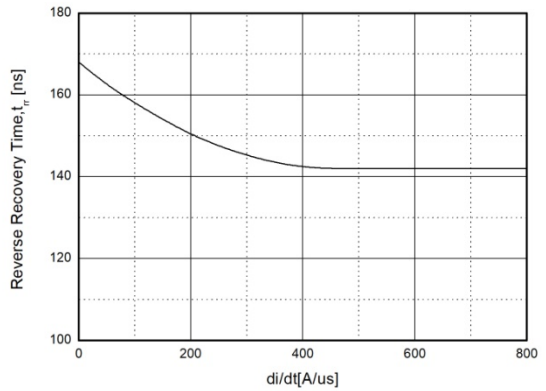

Fig. 3. Transient Thermal Impedance Characteristics ( $R_{th(J-C)}$ )

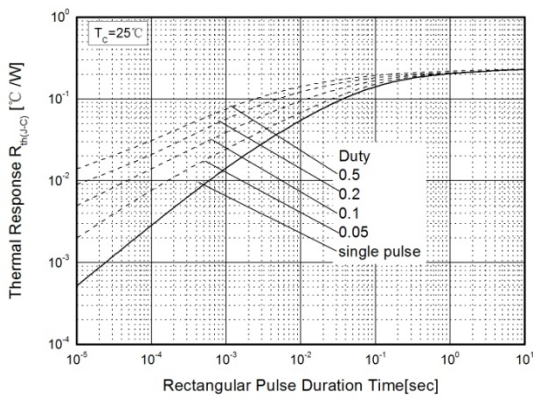
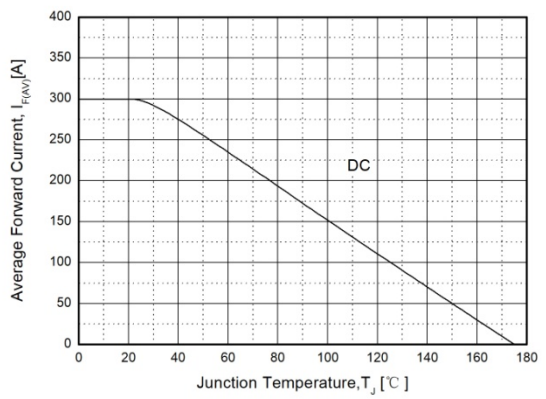
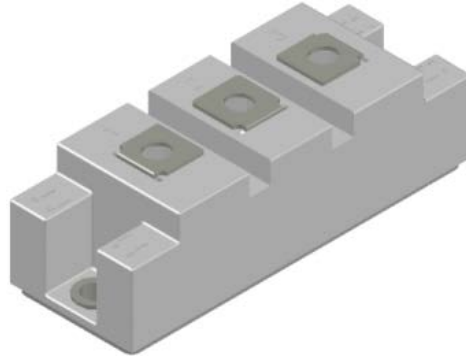

Fig. 4. Forward Current Derating Curve



**Package Dimensions**

**D1**



(Dimensions in Millimeters)

