

## 1200V FRD Full Bridge Module

### Description

The Fast Recovery Diode module devices used Full Bridge Structure, and optimized to reduce losses and EMI/RFI in high frequency power conditioning electrical systems.

The Fast Recovery Diode module is ideally suited for power converters, inverter welders, motor drives and other applications where switching losses are significant portion of the total losses.

### Features

- Repetitive Reverse Voltage:  $V_{RRM} = 1200V$
- Low Forward Voltage:  $V_F(\text{typ.}) = 2.0V @ I_F=100A$
- Average Forward Current:  $I_{F(AV)} = 100A @ T_C=100^\circ C$
- Reverse Recovery Time:  $t_{rr}(\text{typ.}) = 140ns$
- Extensive Characterization of Recovery Parameters
- Reduced EMI and RFI
- Isolation Type Package
- $150^\circ C$  Operating Junction Temperature
- Built-in Full Bridge FRD Construction

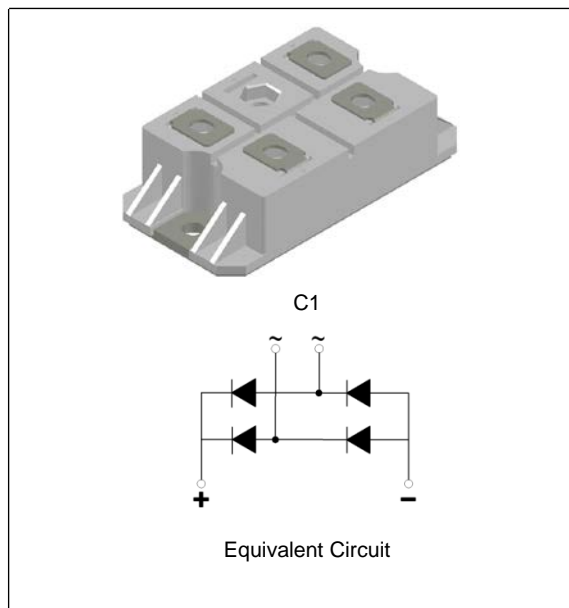

### Applications

- High Speed & High Power Converters, Inverter Welders
- Various Switching and Telecommunication Power Supply
- Cutting Machine

### Absolute Maximum Ratings ( $T_C=25^\circ C$ , unless otherwise noted)

Symbol	Parameter		Ratings	Unit	
$V_{RRM}$	Repetitive Peak Reverse Voltage		1200	V	
$V_R$	DC Blocking Voltage		960	V	
$I_{F(AV)}$	Average Rectified Forward Current	Per Diode	$T_C = 25^\circ C$	200	A
			$T_C = 100^\circ C$	100	
		Per Package	$T_C = 25^\circ C$	800	
			$T_C = 100^\circ C$	400	
$I_{FSM}$	Non-repetitive Peak Surge Current (Per Diode) 60Hz Single Half-sine Wave		1750	A	
$I^2t$	$I^2t$ For Fusing 60Hz Sine Wave		$12.7 * 10^3$	$A^2S$	
$P_D$	Maximum Power Dissipation		360	W	
$V_{iso}$	Isolation Voltage @AC 1 Minutes		2500	V	
$T_J$	Junction Temperature		-55 ~ +150	$^\circ C$	
$T_{STG}$	Storage Temperature Range		-55 ~ +150	$^\circ C$	
	Mounting Torque (M5)		4.0	N.m	
	Terminal Torque (M5)		2.0	N.m	
	Weight		137	g	

## Electrical Characteristics (Per Diode, $T_C=25\text{ }^\circ\text{C}$ , unless otherwise noted)

Symbol	Parameter	Conditions	Min.	Typ.	Max.	Unit
$V_F$	Forward Voltage Drop	$I_F=100\text{A}$	-	2.0	2.4	V
		$I_F=100\text{A}$ , $T_C=100\text{ }^\circ\text{C}$	-	1.7	-	V
$I_{RM}$	Reverse Leakage Current	$V_R=600\text{V}$	-	-	0.5	mA
		$V_R=600\text{V}$ , $T_C=100\text{ }^\circ\text{C}$	-	-	1	mA
$t_{rr}$	Reverse Recovery Time	$I_F=1\text{A}$ , $di/dt=-200\text{A/us}$	-	35	-	ns
$t_{rr}$	Reverse Recovery Time	$I_F=100\text{A}$ , $di/dt=-200\text{A/us}$	-	140	170	ns
$I_{rr}$	Reverse Recovery Current		-	22.0	-	A
$t_{rr}$	Reverse Recovery Time	$I_F=100\text{A}$ , $di/dt=-200\text{A/us}$ , $T_C=100\text{ }^\circ\text{C}$	-	530	-	ns
$I_{rr}$	Reverse Recovery Current		-	39.0	-	A

## Thermal Characteristics

Symbol	Parameter	Ratings	Unit
$R_{th(J-C)}$	Thermal Resistance, Junction to case	0.34	$^\circ\text{C/W}$

**Typical Performance Characteristics**

Fig. 1. Typical Characteristics:  $V_F$  vs.  $I_F$

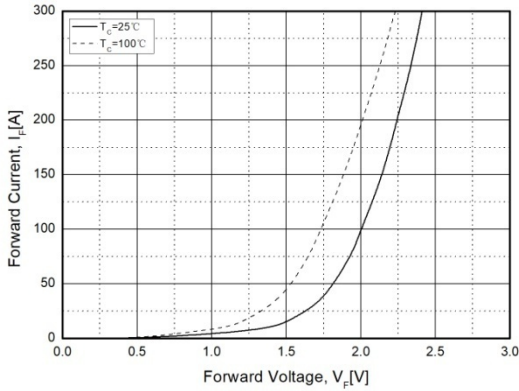

Fig. 2. Typical Reverse Recovery Time vs.  $di/dt$

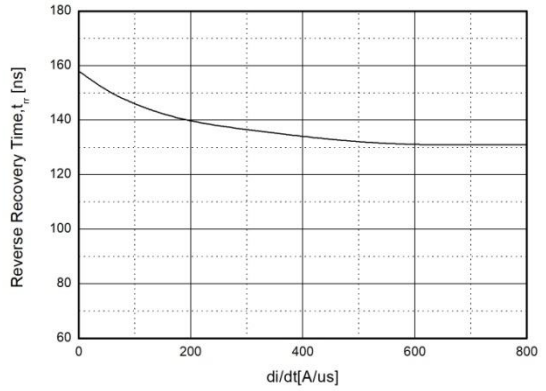

Fig. 3. Transient Thermal Impedance Characteristics ( $R_{th(J-C)}$ )

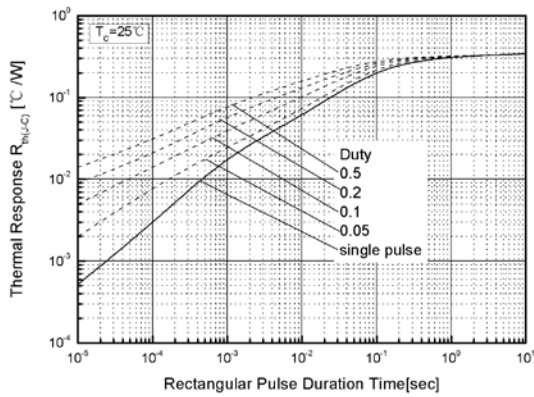
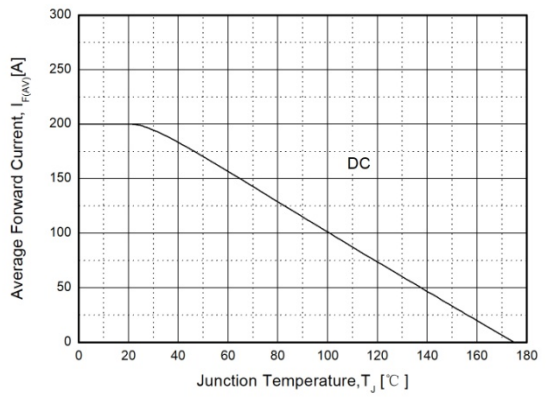
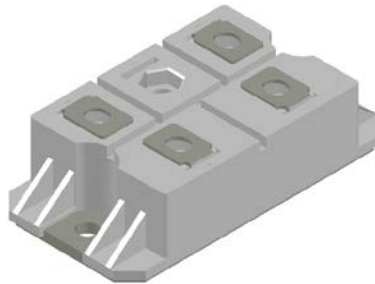

Fig. 4. Forward Current Derating Curve



**Package Dimensions**

**C1**



(Dimensions in Millimeters)

