

## 650V 80A FieldStop Trench IGBT

### Description

The device is designed by advanced FieldStop Trench technology process. This IGBT offer low  $V_{CE(sat)}$ , high speed switching performance and excellent quality for application such as PFC,UPS, Welder, PV Inverter, Solar Inverter and other switching applications.

### Features

- FieldStop Trench Technology, Positive temperature coefficient
- $V_{CE(sat)}=1.75V@I_C=80A$
- $t_{rr}=71ns$  (typ.)
- High Speed Switching & Low Power Loss
- High Input Impedance

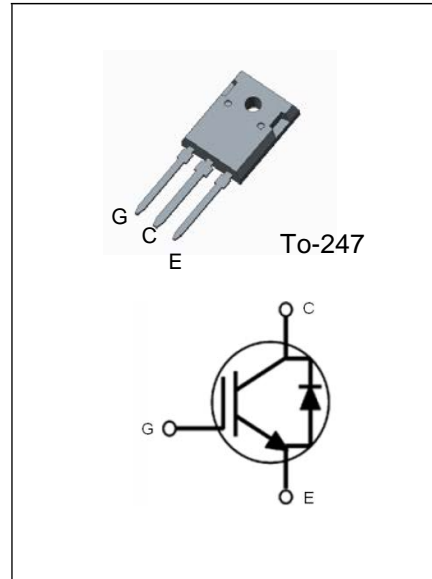

### Applications

- PFC, UPS, Welder, PV Inverter, Solar Inverter

### Absolute Maximum Ratings

Symbol	Parameter	Ratings	Unit	
$V_{CES}$	Collector to Emitter Voltage	650	V	
$V_{GES}$	Gate to Emitter Voltage	$\pm 20$	V	
$I_C$	Collector Current	$T_C=25^\circ C$	160	A
		$T_C=125^\circ C$	80	A
$I_{CM}$	Pulsed Collector Current	240	A	
$I_F$	Diode Continuous Forward Current	$T_C=125^\circ C$	30	A
$I_{FSM}$	Non-repetitive Peak Surge Current	180	A	
$P_D$	Maximum Power Dissipation	$T_C=25^\circ C$	428	W
		$T_C=125^\circ C$	214	W
$T_J$	Operating Junction Temperature Range	-50~+175	$^\circ C$	
$T_{STG}$	Storage Temperature Range	-50~+150	$^\circ C$	

### Thermal Characteristics

Symbol	Parameter	Ratings	Unit
$R_{th(J-C)}$ (IGBT)	Thermal Resistance, Junction to case for IGBT	0.35	$^\circ C/W$
$R_{th(J-C)}$ (Diode)	Thermal Resistance, Junction to case for Diode	0.78	$^\circ C/W$
$R_{th(J-A)}$	Thermal Resistance, Junction to Ambient	40	$^\circ C/W$

## Electrical Characteristics of IGBT @ $T_C=25\text{ }^\circ\text{C}$ unless otherwise noted

Symbol	Parameter	Conditions	Min.	Typ.	Max.	Unit
$BV_{CES}$	Collector to Emitter Breakdown Voltage	$V_{GE}=0V, I_C=250\mu A$	650	-	-	V
$V_{CE(sat)}$	Collector to Emitter Saturation Voltage	$I_C=80A, V_{GE}=15V$	-	1.75	2.1	V
		$I_C=80A, V_{GE}=15V, T_C=125^\circ\text{C}$	-	2.1	-	V
$V_{GE(th)}$	Gate Threshold Voltage	$V_{CE}=V_{GE}, I_C=250\mu A$	4.0	4.76	6.0	V
$I_{CES}$	Zero Gate Voltage Collector Current	$V_{CE}=V_{CES}, V_{GE}=0V$	-	-	10	$\mu A$
$I_{GES}$	Gate to Emitter Leakage Current	$V_{GE}=V_{GES}, V_{CE}=0V$	-	-	$\pm 250$	nA

## Electrical Characteristics of Diode @ $T_C=25\text{ }^\circ\text{C}$ unless otherwise noted

Symbol	Parameter	Conditions	Min.	Typ.	Max.	Unit
$V_F$	Diode Forward Voltage	$I_F=30A$	-	1.36	1.8	V
		$I_F=30A, T_C=125^\circ\text{C}$	-	1.20	-	V
$t_{rr}$	Diode Reverse Recovery Time	$I_F=30A, di/dt=-240A/\mu s$	-	71	-	ns
$I_{rr}$	Diode Peak Reverse Recovery Current		-	9.6	-	A
$Q_{rr}$	Diode Reverse Recovery Charge		-	425	-	nC

## Switching Characteristics @ $T_C=25\text{ }^\circ\text{C}$ unless otherwise noted

Symbol	Parameter	Conditions	Min.	Typ.	Max.	Unit
$t_{d(on)}$	Turn-on Delay Time	$I_C=80A, V_{CC}=325V, V_{GE}=15V, R_G=7\Omega, \text{Inductive Load}, T_C=25^\circ\text{C}$	-	30.5	-	ns
$t_r$	Rising Time		-	82.5	-	ns
$t_{d(off)}$	Turn-off Delay Time		-	127.8	-	ns
$t_f$	Falling Time		-	21.7	-	ns
$E_{on}$	Turn-on Switching Loss		-	1.45	-	mJ
$E_{off}$	Turn-off Switching Loss		-	0.55	-	mJ
$E_{ts}$	Total Switching Loss		-	2.00	-	mJ
$t_{d(on)}$	Turn-on Delay Time	$I_C=80A, V_{CC}=325V, V_{GE}=15V, R_G=7\Omega, \text{Inductive Load}, T_C=125^\circ\text{C}$	-	33.3	-	ns
$t_r$	Rising Time		-	83.4	-	ns
$t_{d(off)}$	Turn-off Delay Time		-	139.1	-	ns
$t_f$	Falling Time		-	28.1	-	ns
$E_{on}$	Turn-on Switching Loss		-	1.95	-	mJ
$E_{off}$	Turn-off Switching Loss		-	0.90	-	mJ
$E_{ts}$	Total Switching Loss		-	2.85	-	mJ
$C_{ies}$	Input Capacitance	$V_{GE}=0V, V_{CE}=25V, f=1.0\text{MHz}$	-	3496	-	pF
$C_{res}$	Reverse Transfer Capacitance		-	103	-	pF
$C_{oes}$	Output Capacitance		-	14	-	pF
tsc	Short Circuit With stand Time	$V_{CC}=325V, V_{GE}=15V$	5	-	-	us

**Typical Performance Characteristics**

Fig. 1. Typical Output Characteristics

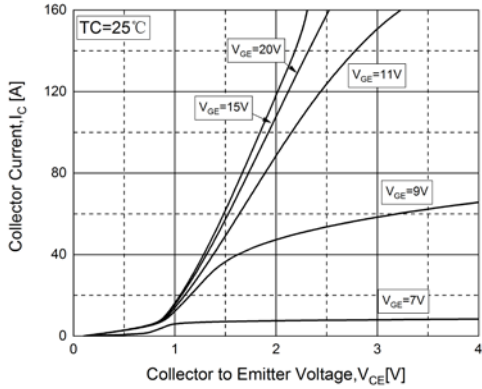

Fig. 2. Typical Saturation Voltage Characteristics

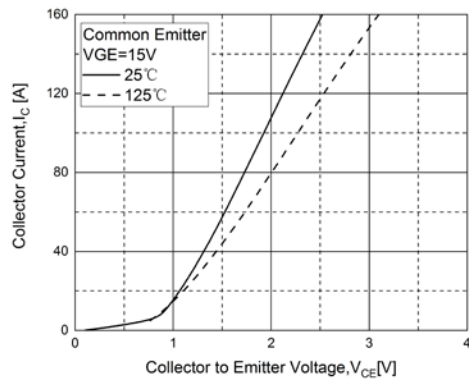

Fig. 3. Typical Saturation Voltage vs.  $T_C$

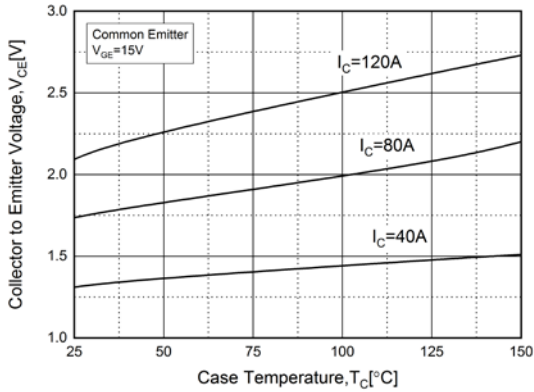

Fig. 4. Diode Forward Characteristics

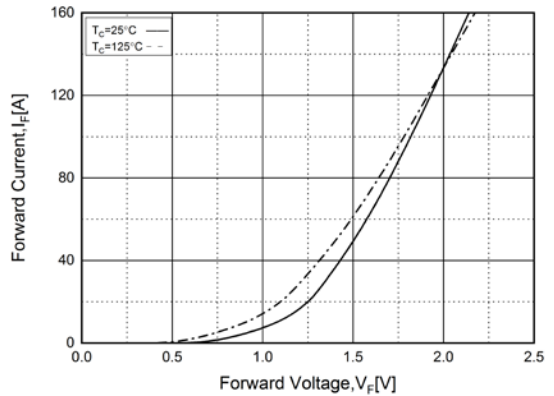

Fig. 5. Typical Capacitance Characteristics

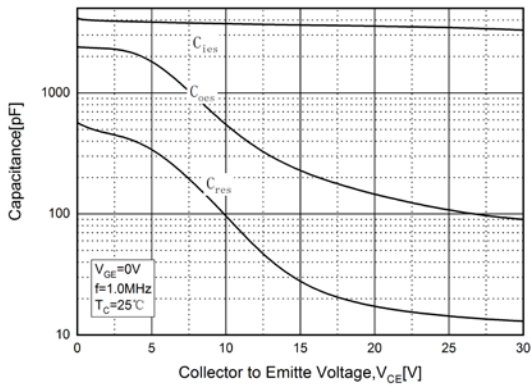
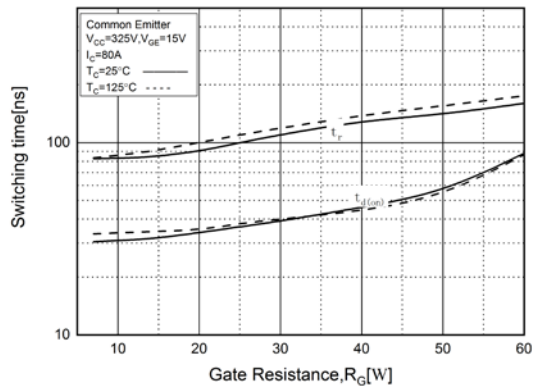

Fig. 6. Turn-on Characteristics vs.  $R_G$



**Typical Performance Characteristics**

Fig. 7. Turn-off Characteristics vs.  $R_G$

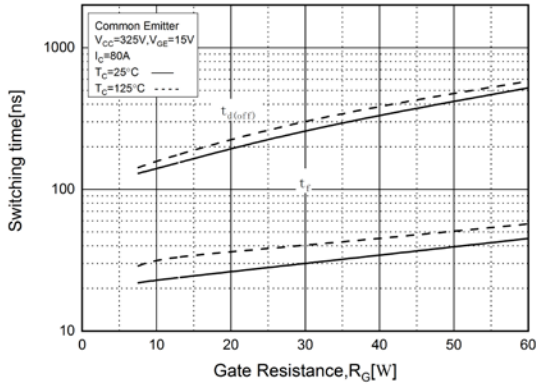

Fig. 8. Switching Loss vs.  $R_G$

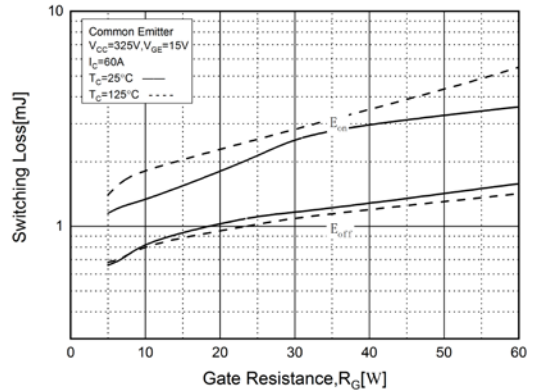

Fig. 9. Turn-on Characteristics vs.  $I_C$

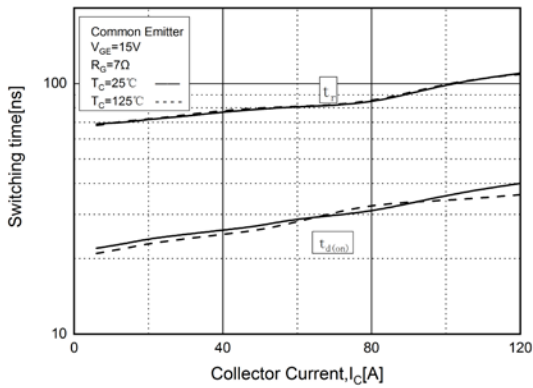

Fig. 10. Turn-off Characteristics vs.  $I_C$

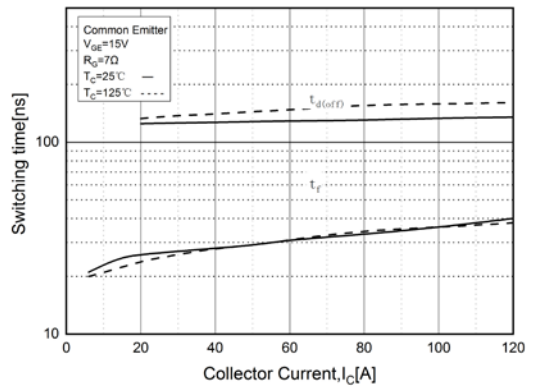
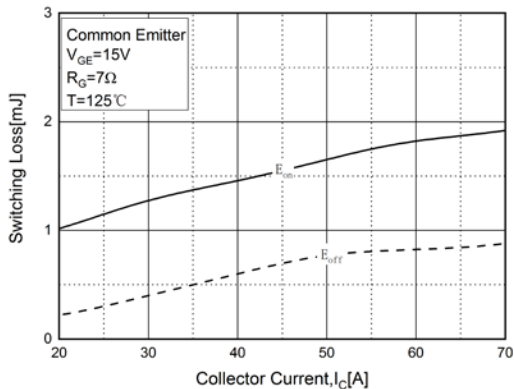

Fig. 11. Switching Loss vs.  $I_C$



**Package Dimensions**

**TO-247**

(Dimensions in Millimeters)

