

3-Level IGBT Module

$V_{CES} = 650V$, $I_{C\ nom} = 100A$ / $I_{CRM} = 200A$

Electrical characteristics :

- 650V Trench /Field Stop type
- Low switching losses
- V_{cesat} has a positive temperature coefficient

Applications:

- 3-Level-Applications
- UPS
- Photovoltaic application

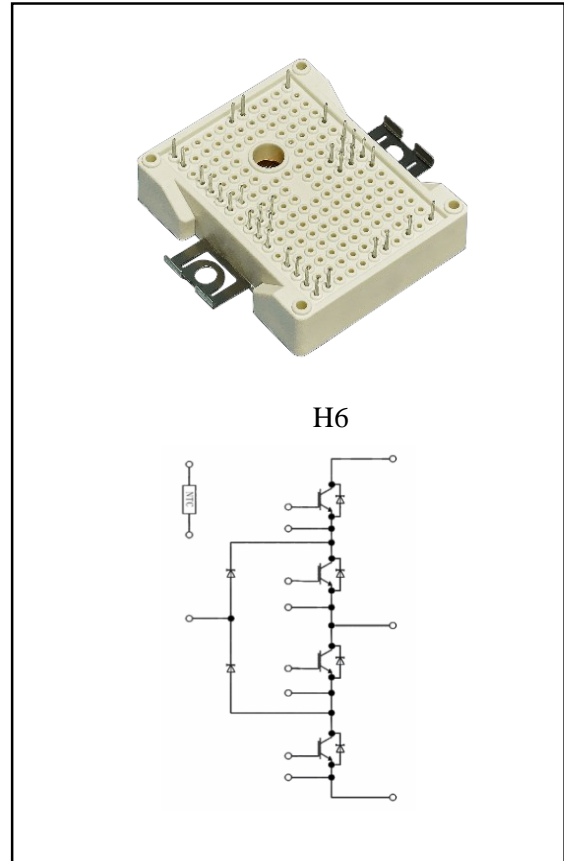

IGBT, Inverter

Maximum Ratings

Parameter	Conditions	Symbol	Value	Unit
Collector-Emitter voltage	$T_{vj} = 25^{\circ}C$	V_{CES}	650	V
Continuous DC collector current	$T_C = 100^{\circ}C$, $T_{vj\ max} = 175^{\circ}C$	$I_{C\ nom}$	100	A
Repetitive peak collector current	$t_p = 1\ ms$	I_{CRM}	200	A
Gate emitter voltage		V_{GE}	± 20	V

Characteristic Values

Parameter	Conditions	Symbol	Value			Unit	
			Min.	Typ.	Max.		
Collector-Emitter saturation voltage	$V_{GE}=15V, I_C=100A$	$T_{vj}=25^{\circ}C$		1.58	2.0	V	
	$V_{GE}=15V, I_C=100A$	$T_{vj}=125^{\circ}C$		1.83			
	$V_{GE}=15V, I_C=100A$	$T_{vj}=150^{\circ}C$		1.87			
Gate-Emitter threshold voltage	$I_C=1.6mA, V_{GE}=V_{CE}$	$T_{vj}=25^{\circ}C$	$V_{GE(th)}$	4.6	5.2	5.8	
Gate charge	$V_{GE} = -15 V \dots +15 V$		Q_G		1.57		μC
Internal gate resistor	$T_{vj} = 25^{\circ}C$		R_{Gint}		None		Ω
Input capacitance	$f=1 MHz, V_{CE}=25 V, V_{GE}=0 V$	$T_{vj}=25^{\circ}C$	C_{ies}		11.12		nF
Reverse transfer capacitance			C_{res}		0.19		nF
Collector-emitter cut-off current	$V_{CE}=650V, V_{GE}=0 V$	$T_{vj}=25^{\circ}C$	I_{CES}			1	mA
Gate-emitter leakage current	$V_{CE}=0 V, V_{GE}=20 V$	$T_{vj}=25^{\circ}C$	I_{GES}			100	nA
Turn-on delay time	$I_C=100A, V_{CE}=300 V$ $V_{GE}=\pm 15 V, R_G=5\Omega$ (inductive load)	$T_{vj}=25^{\circ}C$	$t_{d on}$		17		
		$T_{vj}=125^{\circ}C$			16		
		$T_{vj}=150^{\circ}C$			15		
Rise time	$I_C=100A, V_{CE}=300 V$ $V_{GE}=\pm 15 V, R_G=5\Omega$ (inductive load)	$T_{vj}=25^{\circ}C$	t_r		22		
		$T_{vj}=125^{\circ}C$			25		
		$T_{vj}=150^{\circ}C$			25		
Turn-off delay time	$I_C=100A, V_{CE}=300 V$ $V_{GE}=\pm 15 V, R_G=5\Omega$ (inductive load)	$T_{vj}=25^{\circ}C$	$t_{d off}$		157		ns
		$T_{vj}=125^{\circ}C$			172		
		$T_{vj}=150^{\circ}C$			177		
Fall time	$I_C=100A, V_{CE}=300 V$ $V_{GE}=\pm 15 V, R_G=5\Omega$ (inductive load)	$T_{vj}=25^{\circ}C$	t_f		57		
		$T_{vj}=125^{\circ}C$			61		
		$T_{vj}=150^{\circ}C$			67		
Turn-on energy loss per pulse	$I_C=100A, V_{CE}=300 V$ $V_{GE}=\pm 15 V, R_G=5\Omega$ (inductive load)	$T_{vj}=25^{\circ}C$	E_{on}		0.42		mJ
		$T_{vj}=125^{\circ}C$			0.60		
		$T_{vj}=150^{\circ}C$			0.66		
Turn-off energy loss per pulse	$I_C=100A, V_{CE}=300 V$ $V_{GE}=\pm 15 V, R_G=5\Omega$ (inductive load)	$T_{vj}=25^{\circ}C$	E_{off}		0.82		
		$T_{vj}=125^{\circ}C$			1.07		
		$T_{vj}=150^{\circ}C$			1.17		
Temperature under switching conditions			$T_{vj op}$	-40		150	$^{\circ}C$

Diode, Inverter

Maximum Ratings

Parameter	Conditions	Symbol	Value	Unit
Repetitive peak reverse voltage	$T_{vj}=25^{\circ}\text{C}$	V_{RRM}	650	V
Continuous DC forward current		I_F	100	A
Repetitive peak forward current	$t_p=1\text{ms}$	I_{FRM}	200	A
I^2t -value	$V_R = 0\text{ V}, t_p = 10\text{ ms}, T_{vj} = 125^{\circ}\text{C}$	I^2t	1200	A^2s

Characteristic Values

Parameter	Conditions	Symbol	Value			Unit
			Min.	Typ.	Max.	
Forward voltage	$I_F=100\text{A}, V_{GE}=0\text{V}$ $T_{vj}=25^{\circ}\text{C}$	V_F		1.43	1.9	V
	$I_F=100\text{A}, V_{GE}=0\text{V}$ $T_{vj}=125^{\circ}\text{C}$		1.48			
	$I_F=100\text{A}, V_{GE}=0\text{V}$ $T_{vj}=150^{\circ}\text{C}$		1.44			
Peak reverse recovery current	$I_F = 100\text{ A},$ $-diF/dt = 3264\text{A}/\mu\text{s}(T_{vj}=150^{\circ}\text{C})$ $V_R = 300\text{ V}, V_{GE} = -15\text{ V}$ $T_{vj}=25^{\circ}\text{C}$	I_{RM}		70	A	
	$T_{vj}=125^{\circ}\text{C}$		83			
	$T_{vj}=150^{\circ}\text{C}$		90			
Recovered charge	$I_F = 100\text{ A},$ $-diF/dt = 3264\text{A}/\mu\text{s}(T_{vj}=150^{\circ}\text{C})$ $V_R = 300\text{ V}, V_{GE} = -15\text{ V}$ $T_{vj}=25^{\circ}\text{C}$	Q_r		2.33	μC	
	$T_{vj}=125^{\circ}\text{C}$		4.12			
	$T_{vj}=150^{\circ}\text{C}$		4.95			
Reverse recovered energy	$I_F = 100\text{ A},$ $-diF/dt = 3264\text{A}/\mu\text{s}(T_{vj}=150^{\circ}\text{C})$ $V_R = 300\text{ V}, V_{GE} = -15\text{ V}$ $T_{vj}=25^{\circ}\text{C}$	E_{rec}		0.43	mJ	
	$T_{vj}=125^{\circ}\text{C}$		0.82			
	$T_{vj}=150^{\circ}\text{C}$		0.99			
Temperature under switching conditions		$T_{vj\text{ op}}$	-40		150	$^{\circ}\text{C}$

Diode, D5-D6

Maximum Ratings

Parameter	Conditions	Symbol	Value	Unit
Repetitive peak reverse voltage	$T_{vj}=25^{\circ}\text{C}$	V_{RRM}	650	V
Continuous DC forward current		I_F	100	A
Repetitive peak forward current	$t_p=1\text{ms}$	I_{FRM}	200	A
I^2t -value	$t_p=10\text{ms}, \sin 180^{\circ}, T_{vj}=125^{\circ}\text{C}$	I^2t	1200	A^2s

Characteristic Value

Parameter	Conditions	Symbol	Value			Unit
			Min.	Typ.	Max.	
Forward voltage	$I_F=100A, V_{GE}=0V$ $T_{vj}=25^{\circ}C$	V_F		1.47	2.0	V
	$I_F=100A, V_{GE}=0V$ $T_{vj}=125^{\circ}C$			1.53		
	$I_F=100A, V_{GE}=0V$ $T_{vj}=150^{\circ}C$			1.51		
Reverse current	$I_F = 100 A,$ $T_{vj} = 25^{\circ}C$	I_{RM}		74		A
	$-diF/dt = 3699A/\mu s(T_{vj}=150^{\circ}C)$ $T_{vj}=125^{\circ}C$			93		
	$V_R = 300 V, V_{GE} = -15 V$ $T_{vj}=150^{\circ}C$			102		
Recovered charge	$I_F = 100 A,$ $T_{vj} = 25^{\circ}C$	Qr		2.31		μC
	$-diF/dt = 3699A/\mu s(T_{vj}=150^{\circ}C)$ $T_{vj}=125^{\circ}C$			4.13		
	$V_R = 300 V, V_{GE} = -15 V$ $T_{vj}=150^{\circ}C$			5.30		
Reverse recovery energy	$I_F = 100 A,$ $T_{vj} = 25^{\circ}C$	Erec		0.46		mJ
	$-diF/dt = 3699A/\mu s(T_{vj}=150^{\circ}C)$ $T_{vj}=125^{\circ}C$			0.91		
	$V_R = 300 V, V_{GE} = -15 V$ $T_{vj}=150^{\circ}C$			1.20		
Temperature under switching conditions		$T_{vj op}$	-40		150	$^{\circ}C$

NTC-Thermistor
Characteristic Values

Parameter	Conditions	Symbol	Value			Unit
			Min.	Typ.	Max.	
Rated resistances	$T_C=25^{\circ}C, \pm 5\%$	R_{25}		5		$k\Omega$
B-value	$\pm 1\%$	$B_{25/50}$		3380		K

Module

Parameter	Conditions	Symbol	Value			Unit
Isolation test voltage	RMS, $f=50Hz, t=60s$	V_{ISOL}	2500			V
Internal isolation			Al ₂ O ₃			
Storage temperature		T_{stg}	-40		125	$^{\circ}C$
Mounting torque for modul mounting		M	3.0		6.0	Nm
Weight		W		42		g

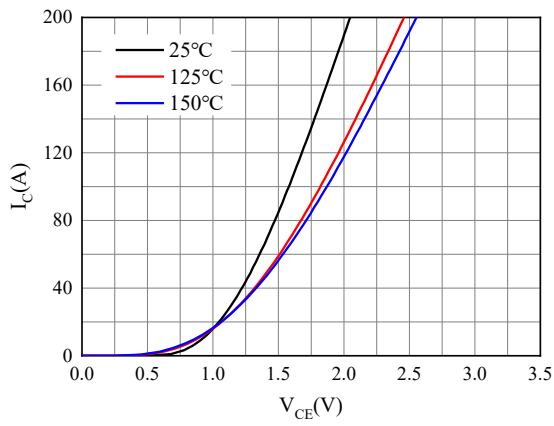

Fig 1. Typical output characteristics ($V_{GE}=15V$)

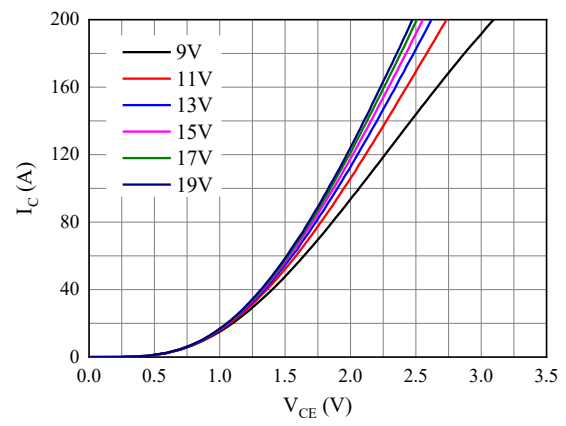

Fig 2. Typical output characteristics ($T_{vj}=150^{\circ}C$)

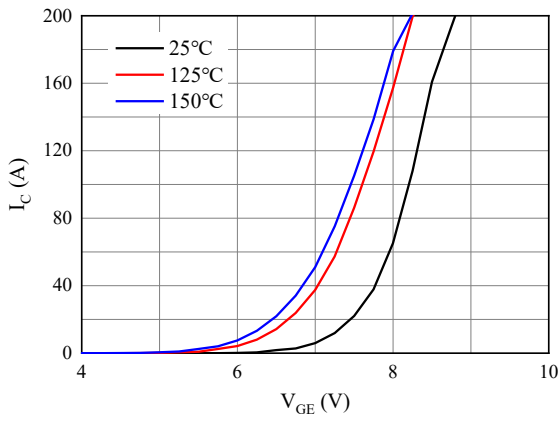

Fig 3. Typical transfer characteristic ($V_{CE}=20V$)

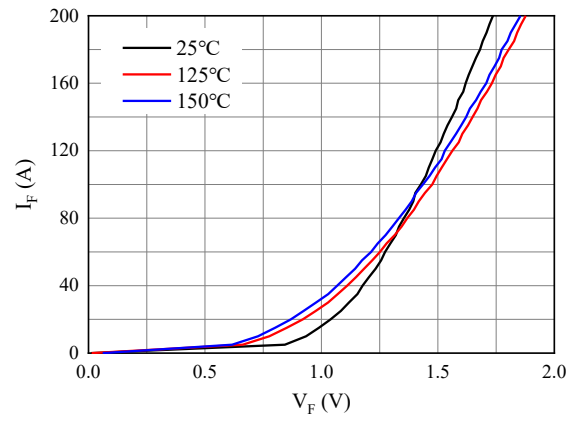

Fig 4. Forward characteristic of Diode

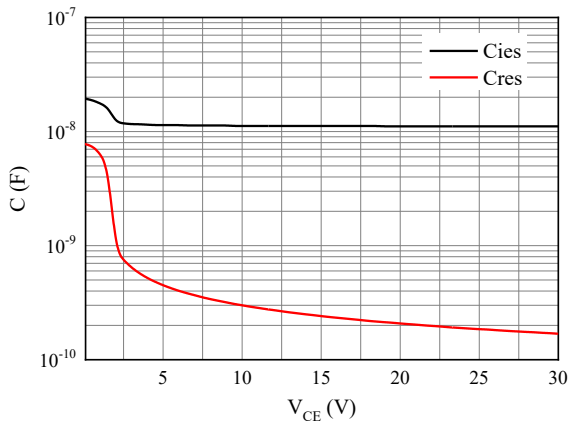

Fig 5. Capacitance characteristic

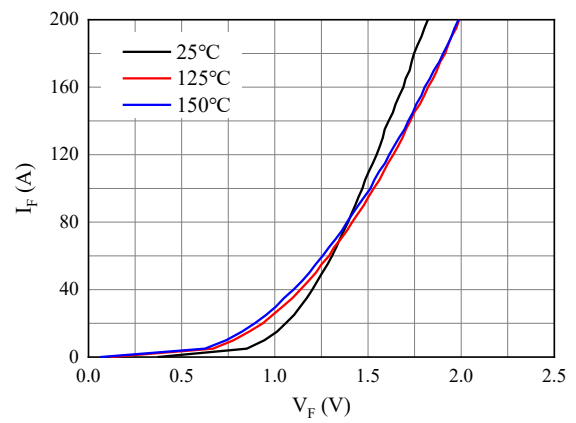

Fig 6. Forward characteristic of Diode, D5-D6

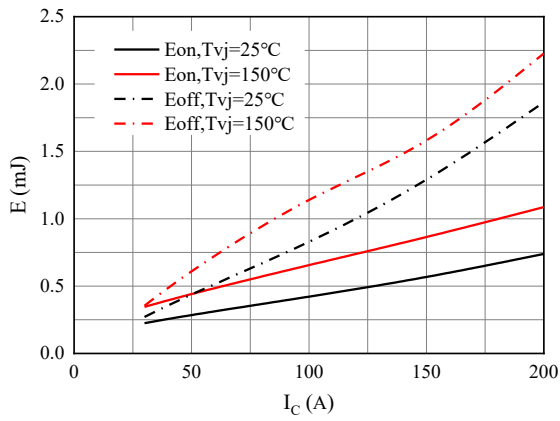

Fig 7. Switching losses of IGBT

VGE=±15V, RGon=5Ω, RGoff=5Ω, VCE=300V

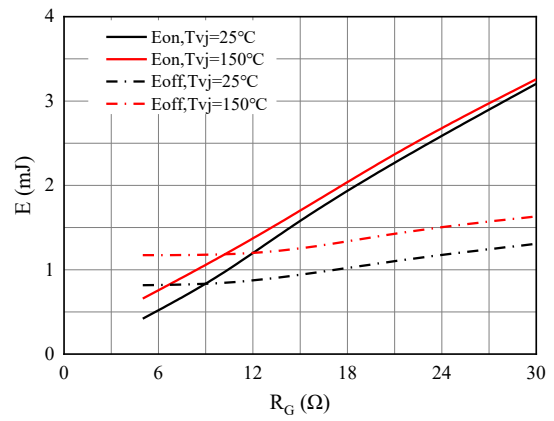

Fig 8. Switching losses of IGBT

VGE=±15V, IC=100A, VCE=300V

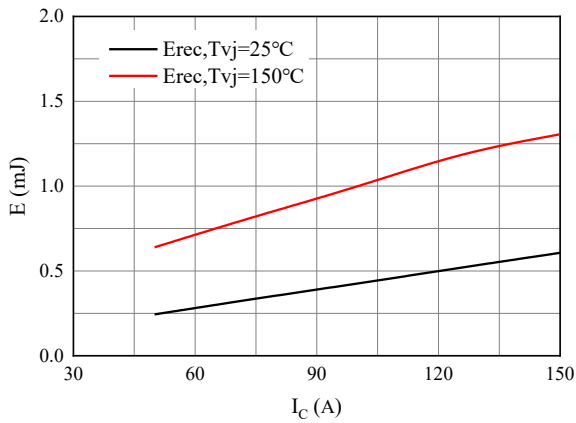

Fig 9. Switching losses of Diode

RGon=5Ω, VCE=300V

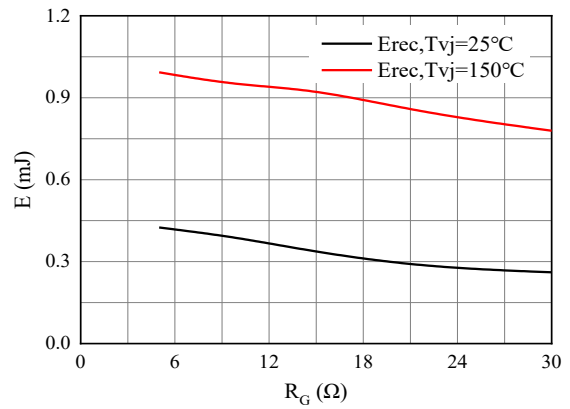

Fig 10. Switching losses of Diode

IF=100A, VCE=300V

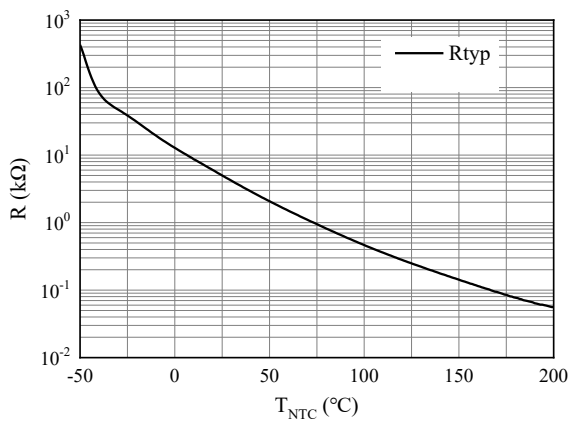
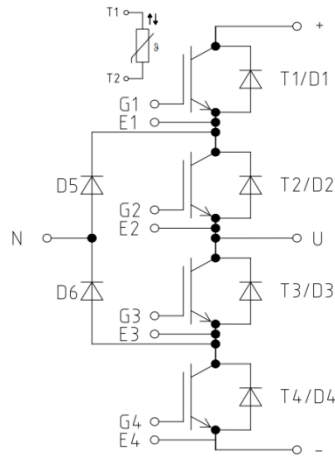
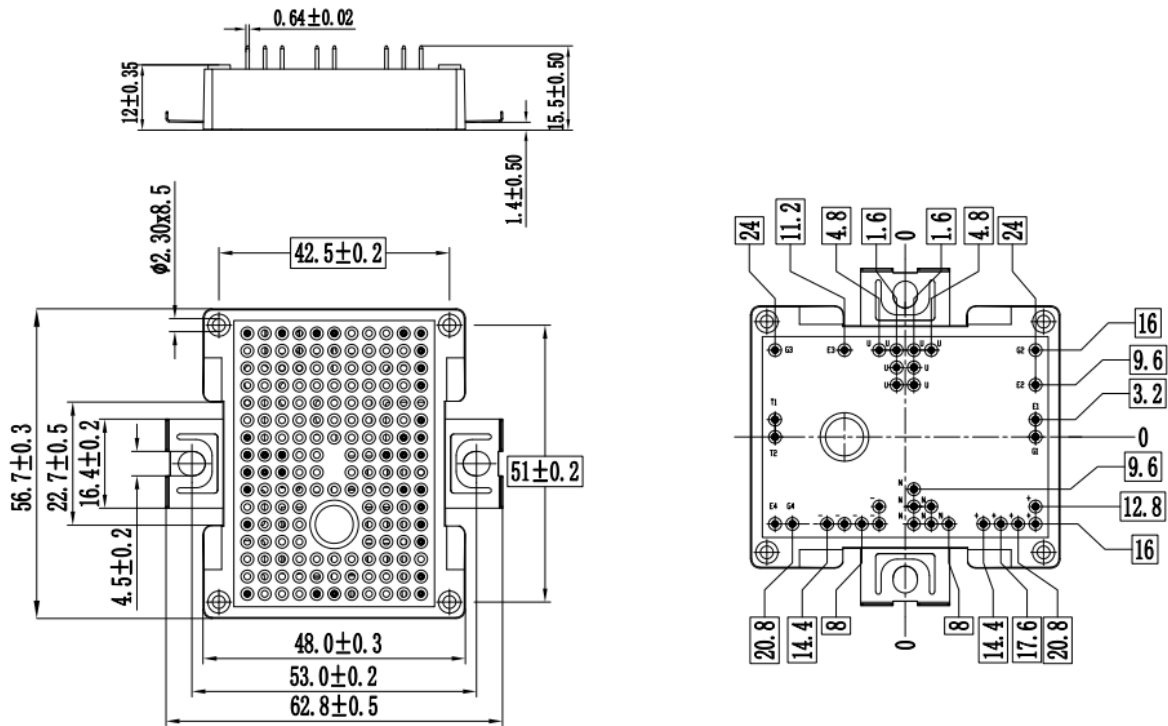

Fig 11. NTC-Themistor-temperature characteristic

Circuit diagram



Package outlines



Dimensions in (mm)