

34mm Half Bridge IGBT Module

$V_{CES} = 650V$, $I_{C\ nom} = 100A$ / $I_{CRM} = 200A$

Electrical characteristics :

- 650V Trench / Field Stop process
- Low switching losses
- V_{cesat} has a positive temperature coefficient

Applications:

- Inverter welding machine
- Induction heating

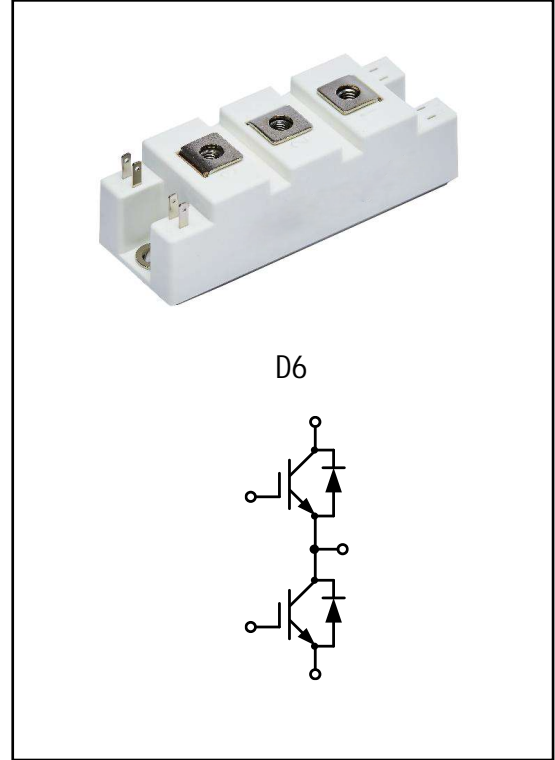

IGBT, Inverter

Maximum Ratings

Parameter	Conditions	Symbol	Value	Unit
Collector-Emitter voltage	$T_{vj} = 25^{\circ}C$	V_{CES}	650	V
Continuous DC collector current	$T_C = 100^{\circ}C$, $T_{vj\ max} = 175^{\circ}C$	$I_{C\ nom}$	100	A
Repetitive peak collector current	$t_p = 1\ ms$	I_{CRM}	200	A
Total power dissipation	$T_C = 25^{\circ}C$, $T_{vj\ max} = 175^{\circ}C$	P_{tot}	395	W
Gate emitter voltage		V_{GE}	± 20	V

Characteristic Values

Parameter	Conditions	Symbol	Value			Unit
			Min.	Typ.	Max.	
Collector-Emitter saturation voltage	$V_{GE}=15V, I_C=100A$ $V_{GE}=15V, I_C=100A$	$T_{vj}=25^{\circ}C$ $T_{vj}=150^{\circ}C$	V_{CEsat}	1.75 2.23	2.4	V
Gate-Emitter threshold voltage	$I_C = 2.6mA, V_{GE} = V_{CE}$	$T_{vj}=25^{\circ}C$	$V_{GE(th)}$	4.8	5.4	6.0
Gate charge	$V_{GE}=-15V...+15V$		Q_G	0.76		μC
Internal gate resistor			R_{Gint}	none		Ω
Input capacitance	$f=1MHz, V_{CE}=25V, V_{GE}=0V$	$T_{vj}=25^{\circ}C$	C_{ies}	8.28		nF
Reverse transfer capacitance			C_{res}	0.15		
Collector-emitter cut-off current	$V_{CE}=650V, V_{GE}=0V$	$T_{vj}=25^{\circ}C$	I_{CES}		1	mA
Gate-emitter leakage current	$V_{CE}=0V, V_{GE}=20V$	$T_{vj}=25^{\circ}C$	I_{GES}		100	nA
Turn-on delay time	$I_C=100A, V_{CE}=400V$ $V_{GE}=\pm 15V, R_G=1.8\Omega$ (inductive load)	$T_{vj}=25^{\circ}C$ $T_{vj}=150^{\circ}C$	t_{don}	109 103		ns
Rise time	$I_C=100A, V_{CE}=400V$ $V_{GE}=\pm 15V, R_G=1.8\Omega$ (inductive load)	$T_{vj}=25^{\circ}C$ $T_{vj}=150^{\circ}C$	t_r	39 40		
Turn-off delay time	$I_C=100A, V_{CE}=400V$ $V_{GE}=\pm 15V, R_G=1.8\Omega$ (inductive load)	$T_{vj}=25^{\circ}C$ $T_{vj}=150^{\circ}C$	t_{doff}	287 310		
Fall time	$I_C=100A, V_{CE}=400V$ $V_{GE}=\pm 15V, R_G=1.8\Omega$ (inductive load)	$T_{vj}=25^{\circ}C$ $T_{vj}=150^{\circ}C$	t_f	46 64		
Turn-on energy loss per pulse	$I_C=100A, V_{CE}=400V$ $V_{GE}=\pm 15V, R_G=1.8\Omega$ (inductive load)	$T_{vj}=25^{\circ}C$ $T_{vj}=150^{\circ}C$	E_{on}	1.02 1.19		mJ
Turn-off energy loss per pulse	$I_C=100A, V_{CE}=400V$ $V_{GE}=\pm 15V, R_G=1.8\Omega$ (inductive load)	$T_{vj}=25^{\circ}C$ $T_{vj}=150^{\circ}C$	E_{off}	1.03 1.34		
Thermal resistance, junction to case	per IGBT		R_{thJC}		0.38	K/W
Temperature under switching conditions			$T_{vj op}$	-40	150	$^{\circ}C$

Diode, Inverter

Maximum Ratings

Parameter	Conditions	Symbol	Value	Unit
Repetitive peak reverse voltage	$T_{vj}=25^{\circ}\text{C}$	V_{RRM}	650	V
Continuous DC forward current		I_F	60	A
Repetitive peak forward current	$t_p=1\text{ms}$	I_{FRM}	120	A

Characteristic Values

Parameter	Conditions	Symbol	Value			Unit
			Min.	Typ.	Max.	
Forward voltage	$I_F=60\text{A}, V_{GE}=0\text{V}$ $I_F=60\text{A}, V_{GE}=0\text{V}$	$T_{vj}=25^{\circ}\text{C}$ $T_{vj}=150^{\circ}\text{C}$	V_F	1.45 1.51	2.1	V
Peak reverse recovery current	$I_F=60\text{A},$ $-di_F/dt=1557\text{A}/\mu\text{s}(T_{vj}=150^{\circ}\text{C})$ $V_R=400\text{V}, V_{GE}=-15\text{V}$	$T_{vj}=25^{\circ}\text{C}$ $T_{vj}=150^{\circ}\text{C}$	I_{RM}	48 64		A
Recovered charge	$I_F=60\text{A},$ $-di_F/dt=1557\text{A}/\mu\text{s}(T_{vj}=150^{\circ}\text{C})$ $V_R=400\text{V}, V_{GE}=-15\text{V}$	$T_{vj}=25^{\circ}\text{C}$ $T_{vj}=150^{\circ}\text{C}$	Q_r	1.6 3.1		μC
Reverse recovered energy	$I_F=60\text{A},$ $-di_F/dt=1557\text{A}/\mu\text{s}(T_{vj}=150^{\circ}\text{C})$ $V_R=400\text{V}, V_{GE}=-15\text{V}$	$T_{vj}=25^{\circ}\text{C}$ $T_{vj}=150^{\circ}\text{C}$	E_{rec}	0.44 0.90		mJ
Thermal resistance, junction to case	per diode		R_{thJC}		0.58	K/W
Temperature under switching conditions			$T_{vj\ op}$	-40	150	$^{\circ}\text{C}$

Module

Parameter	Conditions	Symbol	Value			Unit
Isolation test voltage	RMS, $f=50\text{Hz}$, $t=1\text{min}$	V_{ISOL}	4000			V
Internal isolation			Al_2O_3			
Storage temperature		T_{stg}	-40		125	$^{\circ}\text{C}$
Mounting torque for modul mounting		M	3.0		6.0	Nm
Weight		W		155		g

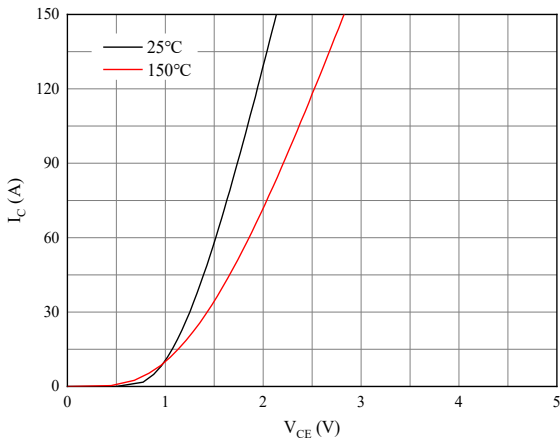

Fig 1. Typical output characteristics ($V_{GE}=15V$)

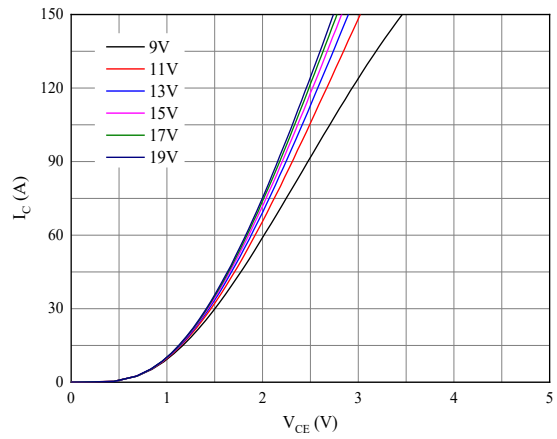

Fig 2. Typical output characteristics ($T_{vj}=150^{\circ}C$)

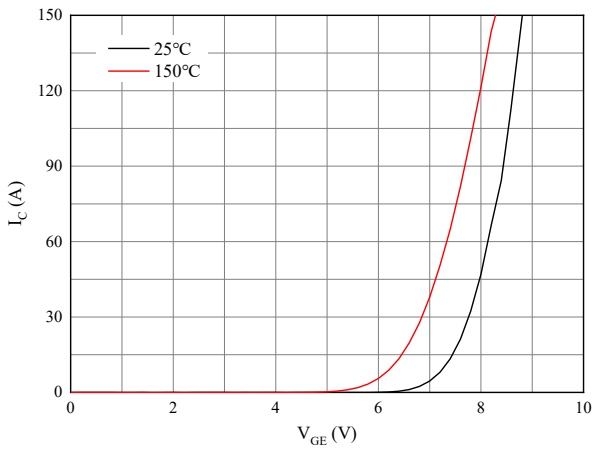

Fig 3. Typical transfer characteristic ($V_{CE}=20V$)

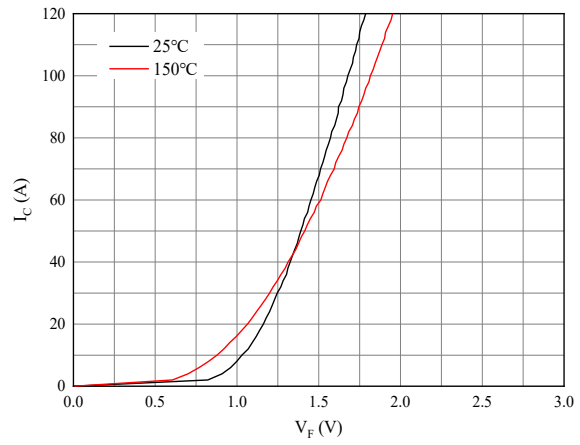

Fig 4. Forward characteristic of Diode

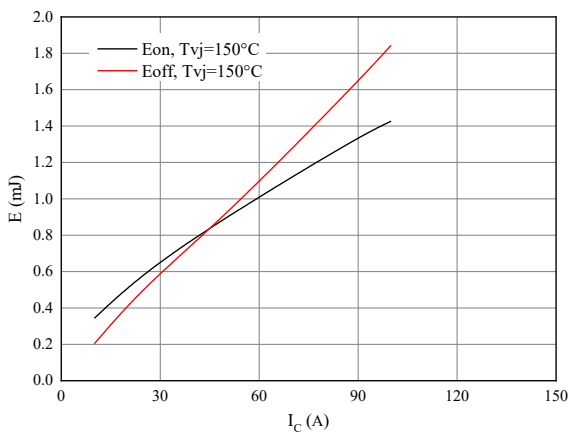

Fig 5. Switching losses of IGBT
 $V_{GE}=\pm 15V$, $R_{Gon}=1.8\Omega$, $R_{Goff}=1.8\Omega$, $V_{CE}=400V$

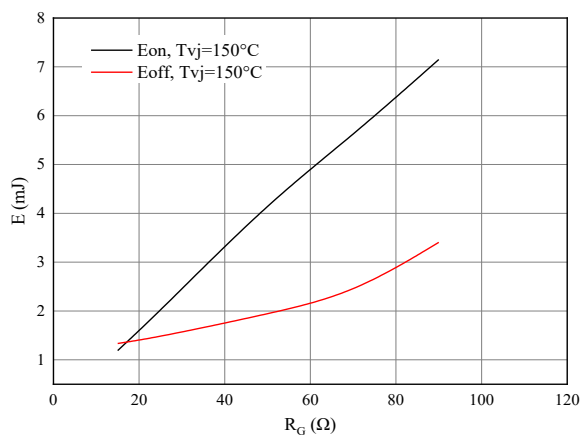

Fig 6. Switching losses of IGBT
 $V_{GE}=\pm 15V$, $I_C=100A$, $V_{CE}=400V$

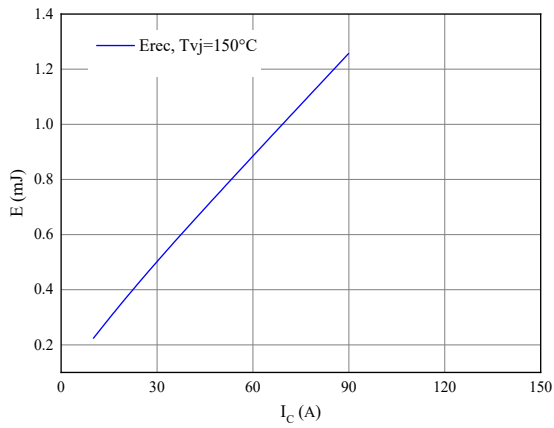

Fig 7. Switching losses of Diode

$R_{Gon}=1.8\Omega$, $V_{CE}=400V$

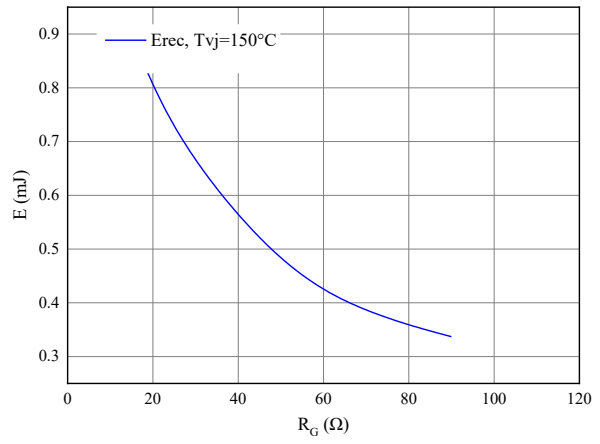

Fig 8. Switching losses of Diode

$I_F=60A$, $V_{CE}=400V$

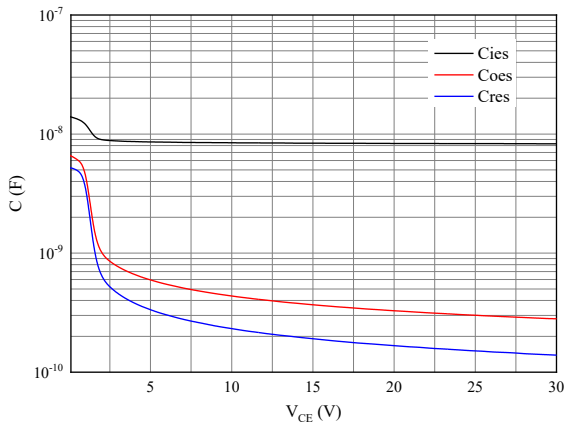
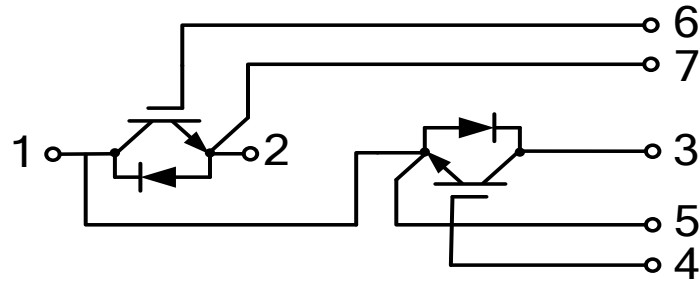

Fig 9. Capacitance characteristic

Circuit diagram



Package outlines

