

## 3-Level IGBT Module

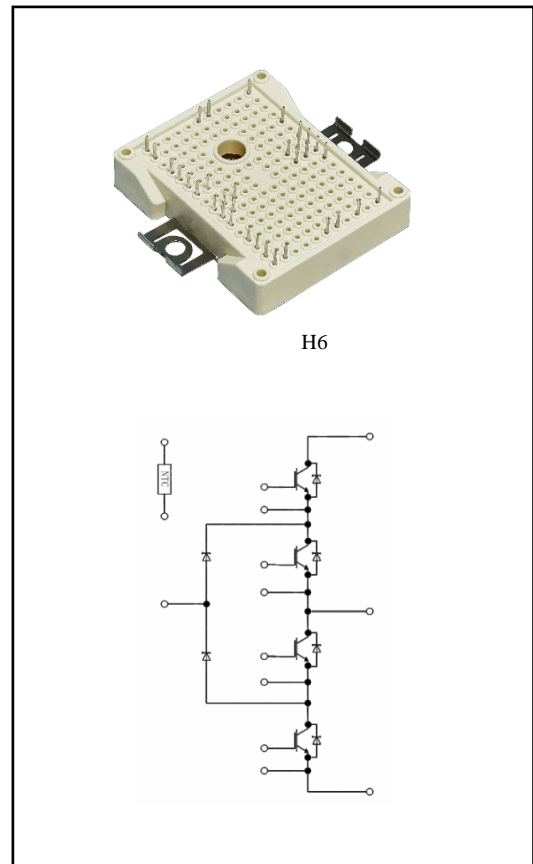
$V_{CES} = 650V$ ,  $I_{C\ nom} = 150A$  /  $I_{CRM} = 300A$

### Electrical characteristics :

- Trench /Field Stop process
- Low switching losses
- $V_{cesat}$  has a positive temperature coefficient

### Applications:

- 3-Level-Applications
- UPS
- Photovoltaic application



## IGBT, Inverter

### Maximum Ratings

Parameter	Conditions	Symbol	Value	Unit
Collector-Emitter voltage	$T_{vj} = 25^{\circ}C$	$V_{CES}$	650	V
Continuous DC collector current	$T_C = 100^{\circ}C$ , $T_{vj\ max} = 175^{\circ}C$	$I_{C\ nom}$	150	A
Repetitive peak collector current	$t_p = 1\ ms$	$I_{CRM}$	300	A
Gate emitter voltage		$V_{GE}$	$\pm 20$	V

## Characteristic Values

Parameter	Conditions	Symbol	Value			Unit
			Min.	Typ.	Max.	
Collector-Emitter saturation voltage	$V_{GE}=15V, I_C=150A$	$T_{vj}=25^{\circ}C$	$V_{CEsat}$	1.57	1.95	V
	$V_{GE}=15V, I_C=150A$	$T_{vj}=125^{\circ}C$		1.82		
	$V_{GE}=15V, I_C=150A$	$T_{vj}=150^{\circ}C$		1.86		
Gate-Emitter threshold voltage	$I_C=2.4mA, V_{GE}=V_{CE}$	$T_{vj}=25^{\circ}C$	$V_{GE(th)}$	4.7	5.3	5.9
Gate charge	$V_{GE} = -15 V \dots +15 V$		$Q_G$		1.54	$\mu C$
Internal gate resistor	$T_{vj} = 25^{\circ}C$		$R_{Gint}$		None	$\Omega$
Input capacitance	$f=1 MHz, V_{CE}=25 V, V_{GE}=0 V$	$T_{vj}=25^{\circ}C$	$C_{ies}$		16.47	nF
Reverse transfer capacitance			$C_{res}$		0.27	nF
Collector-emitter cut-off current	$V_{CE}=650V, V_{GE}=0 V$	$T_{vj}=25^{\circ}C$	$I_{CES}$			1 mA
Gate-emitter leakage current	$V_{CE}=0 V, V_{GE}=20 V$	$T_{vj}=25^{\circ}C$	$I_{GES}$			400 nA
Turn-on delay time	$I_C=150A, V_{CE}=300 V$ $V_{GE}=\pm 15 V, R_G=3.3\Omega$ (inductive load)	$T_{vj}=25^{\circ}C$	$t_{d on}$		12	ns
		$T_{vj}=125^{\circ}C$			12	
		$T_{vj}=150^{\circ}C$			14	
Rise time	$I_C=150A, V_{CE}=300 V$ $V_{GE}=\pm 15 V, R_G=3.3\Omega$ (inductive load)	$T_{vj}=25^{\circ}C$	$t_r$		28	ns
		$T_{vj}=125^{\circ}C$			29	
		$T_{vj}=150^{\circ}C$			31	
Turn-off delay time	$I_C=150A, V_{CE}=300 V$ $V_{GE}=\pm 15 V, R_G=3.3\Omega$ (inductive load)	$T_{vj}=25^{\circ}C$	$t_{d off}$		167	ns
		$T_{vj}=125^{\circ}C$			180	
		$T_{vj}=150^{\circ}C$			182	
Fall time	$I_C=150A, V_{CE}=300 V$ $V_{GE}=\pm 15 V, R_G=3.3\Omega$ (inductive load)	$T_{vj}=25^{\circ}C$	$t_f$		54	ns
		$T_{vj}=125^{\circ}C$			59	
		$T_{vj}=150^{\circ}C$			63	
Turn-on energy loss per pulse	$I_C=150A, V_{CE}=300 V$ $V_{GE}=\pm 15 V, R_G=3.3\Omega$ (inductive load)	$T_{vj}=25^{\circ}C$	$E_{on}$		0.66	mJ
		$T_{vj}=125^{\circ}C$			0.83	
		$T_{vj}=150^{\circ}C$			0.91	
Turn-off energy loss per pulse	$I_C=150A, V_{CE}=300 V$ $V_{GE}=\pm 15 V, R_G=3.3\Omega$ (inductive load)	$T_{vj}=25^{\circ}C$	$E_{off}$		1.28	mJ
		$T_{vj}=125^{\circ}C$			1.66	
		$T_{vj}=150^{\circ}C$			1.80	
Temperature under switching conditions			$T_{vj op}$	-40		150 $^{\circ}C$

## Diode, Inverter

### Maximum Ratings

Parameter	Conditions	Symbol	Value	Unit
Repetitive peak reverse voltage	$T_{vj}=25^{\circ}\text{C}$	$V_{RRM}$	650	V
Continuous DC forward current		$I_F$	150	A
Repetitive peak forward current	$t_p=1\text{ms}$	$I_{FRM}$	300	A
$I^2t$ -value	$V_R = 0\text{ V}, t_p = 10\text{ ms}, T_{vj} = 125^{\circ}\text{C}$	$I^2t$	1200	$\text{A}^2\text{s}$

### Characteristic Values

Parameter	Conditions	Symbol	Value			Unit
			Min.	Typ.	Max.	
Forward voltage	$I_F=150\text{A}, V_{GE}=0\text{V}$ $T_{vj}=25^{\circ}\text{C}$	$V_F$		1.62	2.00	V
	$I_F=150\text{A}, V_{GE}=0\text{V}$ $T_{vj}=125^{\circ}\text{C}$			1.71		
	$I_F=150\text{A}, V_{GE}=0\text{V}$ $T_{vj}=150^{\circ}\text{C}$			1.69		
Peak reverse recovery current	$I_F = 150\text{ A},$ $-diF/dt = 4281\text{ A}/\mu\text{s}(T_{vj}=150^{\circ}\text{C})$ $V_R = 300\text{ V}, V_{GE} = -15\text{ V}$ $T_{vj}=25^{\circ}\text{C}$	$I_{RM}$		83		A
	$T_{vj}=125^{\circ}\text{C}$			102		
	$T_{vj}=150^{\circ}\text{C}$			112		
Recovered charge	$I_F = 150\text{ A},$ $-diF/dt = 4281\text{ A}/\mu\text{s}(T_{vj}=150^{\circ}\text{C})$ $V_R = 300\text{ V}, V_{GE} = -15\text{ V}$ $T_{vj}=25^{\circ}\text{C}$	$Q_r$		3.05		$\mu\text{C}$
	$T_{vj}=125^{\circ}\text{C}$			5.32		
	$T_{vj}=150^{\circ}\text{C}$			6.17		
Reverse recovered energy	$I_F = 150\text{ A},$ $-diF/dt = 4281\text{ A}/\mu\text{s}(T_{vj}=150^{\circ}\text{C})$ $V_R = 300\text{ V}, V_{GE} = -15\text{ V}$ $T_{vj}=25^{\circ}\text{C}$	$E_{rec}$		0.69		mJ
	$T_{vj}=125^{\circ}\text{C}$			1.28		
	$T_{vj}=150^{\circ}\text{C}$			1.49		
Temperature under switching conditions		$T_{vj\text{ op}}$	-40		150	$^{\circ}\text{C}$

## Diode, D5-D6

### Maximum Ratings

Parameter	Conditions	Symbol	Value	Unit
Repetitive peak reverse voltage	$T_{vj}=25^{\circ}\text{C}$	$V_{RRM}$	650	V
Continuous DC forward current		$I_F$	150	A
Repetitive peak forward current	$t_p=1\text{ms}$	$I_{FRM}$	300	A
$I^2t$ -value	$t_p=10\text{ms}, \sin 180^{\circ}, T_{vj}=125^{\circ}\text{C}$	$I^2t$	1200	$\text{A}^2\text{s}$

## Characteristic Value

Parameter	Conditions	Symbol	Value			Unit
			Min.	Typ.	Max.	
Forward voltage	$I_F=150A, V_{GE}=0V$ $T_{vj}=25^{\circ}C$	$V_F$		1.65	2.00	V
	$I_F=150A, V_{GE}=0V$ $T_{vj}=125^{\circ}C$		1.76			
	$I_F=150A, V_{GE}=0V$ $T_{vj}=150^{\circ}C$		1.73			
Reverse current	$I_F = 150 A,$ $- diF/dt=4281A/\mu s(T_{vj}=150^{\circ}C)$ $V_R = 300 V$	$I_{RM}$		83		A
	$T_{vj} = 25^{\circ}C$		102			
	$T_{vj}=125^{\circ}C$ $T_{vj}=150^{\circ}C$		112			
Recovered charge	$I_F = 150 A,$ $- diF/dt=4281A/\mu s(T_{vj}=150^{\circ}C)$ $V_R = 300 V$	$Q_r$		3.05		$\mu C$
	$T_{vj} = 25^{\circ}C$		5.32			
	$T_{vj}=125^{\circ}C$ $T_{vj}=150^{\circ}C$		6.17			
Reverse recovery energy	$I_F = 150 A,$ $- diF/dt=4281A/\mu s(T_{vj}=150^{\circ}C)$ $V_R = 300 V$	Erec		0.69		mJ
	$T_{vj} = 25^{\circ}C$		1.28			
	$T_{vj}=125^{\circ}C$ $T_{vj}=150^{\circ}C$		1.49			
Temperature under switching conditions		$T_{vj op}$	-40		150	$^{\circ}C$

## NTC-Thermistor

### Characteristic Values

Parameter	Conditions	Symbol	Value			Unit
			Min.	Typ.	Max.	
Rated resistances	$T_C=25^{\circ}C, \pm 5\%$	$R_{25}$		5		$k\Omega$
B-value	$\pm 1\%$	$B_{25/50}$		3380		K

## Module

Parameter	Conditions	Symbol	Value			Unit
Isolation test voltage	RMS, $f=50Hz, t=60s$	$V_{ISOL}$	2500			V
Internal isolation			Al <sub>2</sub> O <sub>3</sub>			
Storage temperature		$T_{stg}$	-40		125	$^{\circ}C$
Mounting torque for modul mounting		M	3.0		6.0	Nm
Weight		W		41		g

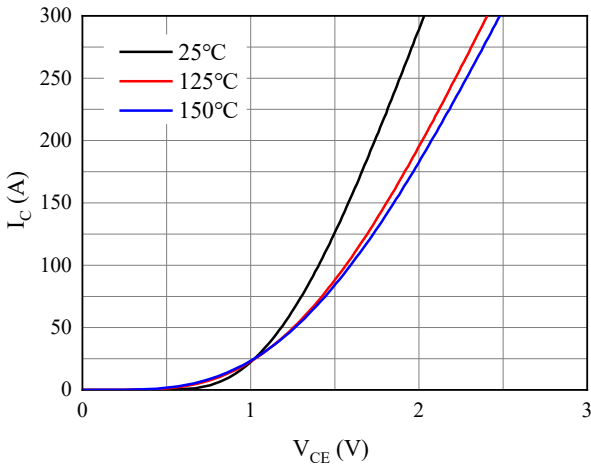


Fig 1. Typical output characteristics ( $V_{GE}=15V$ )

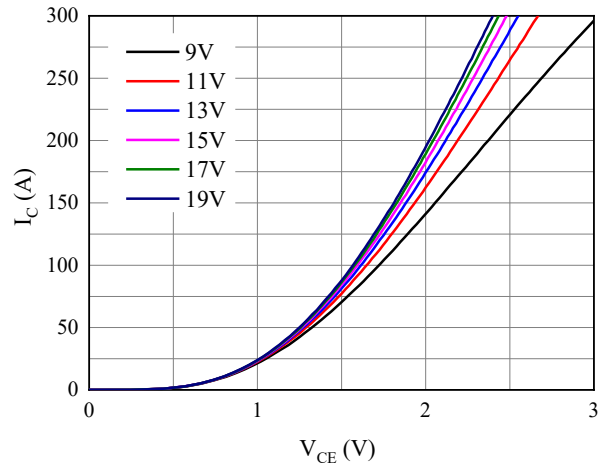


Fig 2. Typical output characteristics ( $T_{vj}=150^{\circ}C$ )

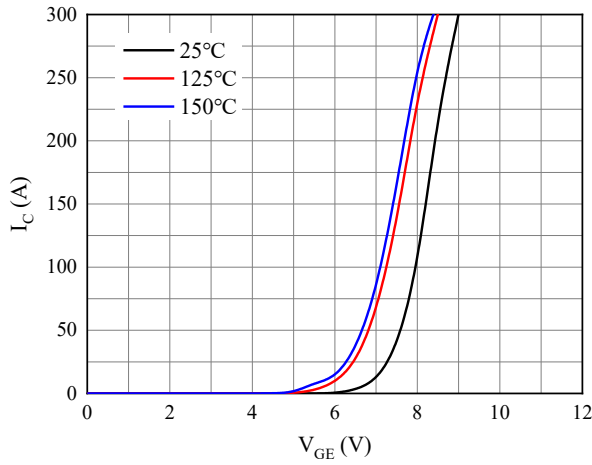


Fig 3. Typical transfer characteristic ( $V_{CE}=20V$ )

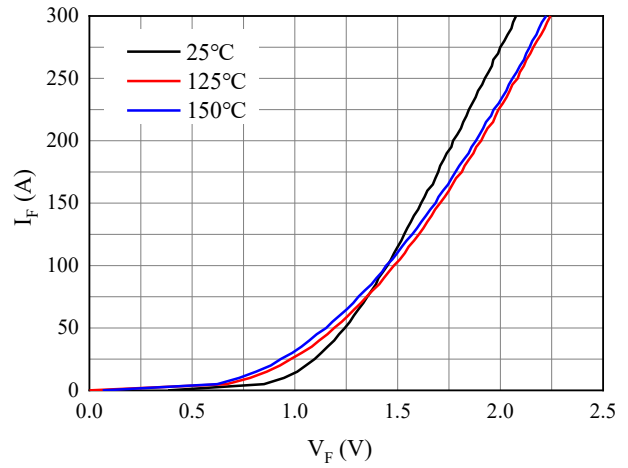


Fig 4. Forward characteristic of Diode

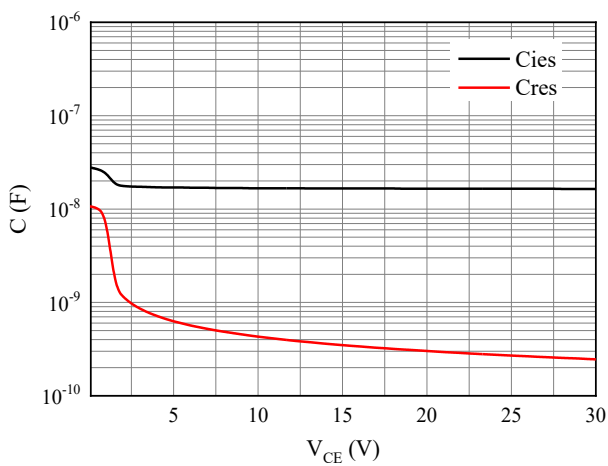


Fig 5. Capacitance characteristic

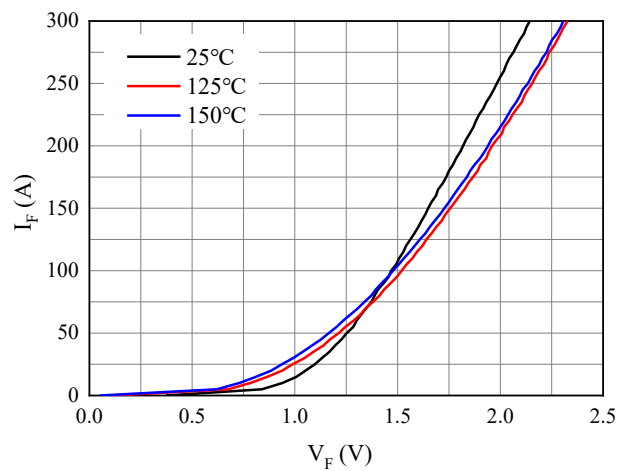
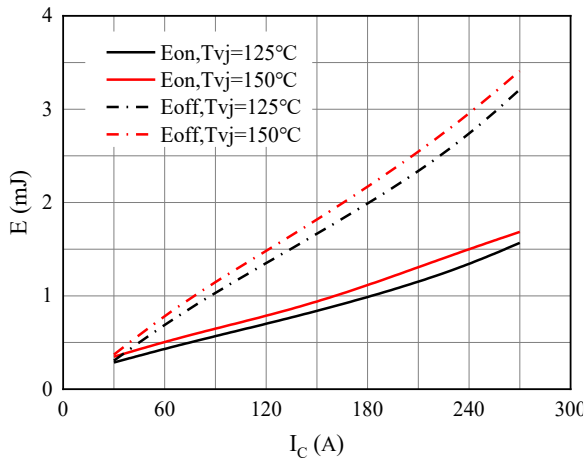
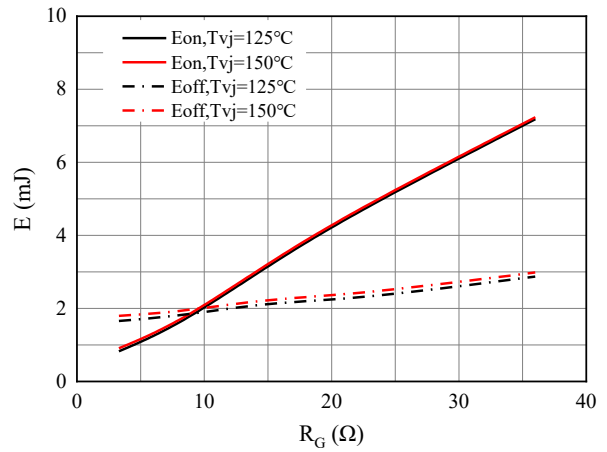


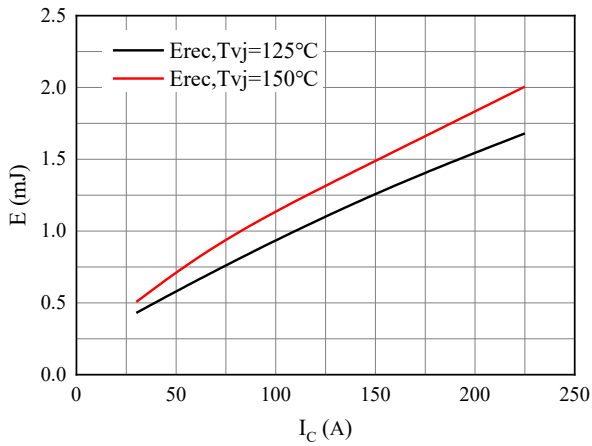
Fig 6. Forward characteristic of Diode, D5-D6



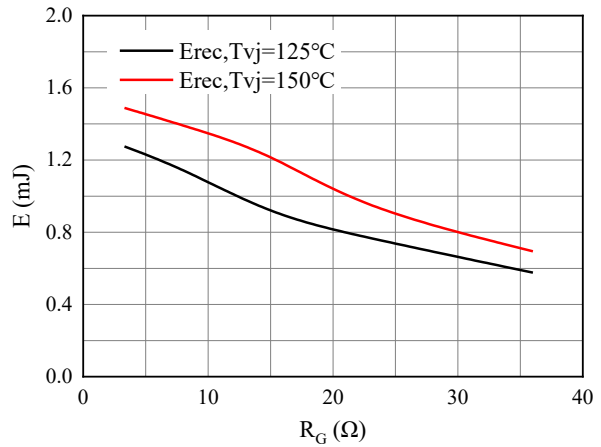
**Fig 7. Switching losses of IGBT**  
 $V_{GE} = \pm 15V$ ,  $R_{Gon} = 3.3\Omega$ ,  $R_{Goff} = 3.3\Omega$ ,  $V_{CE} = 300V$



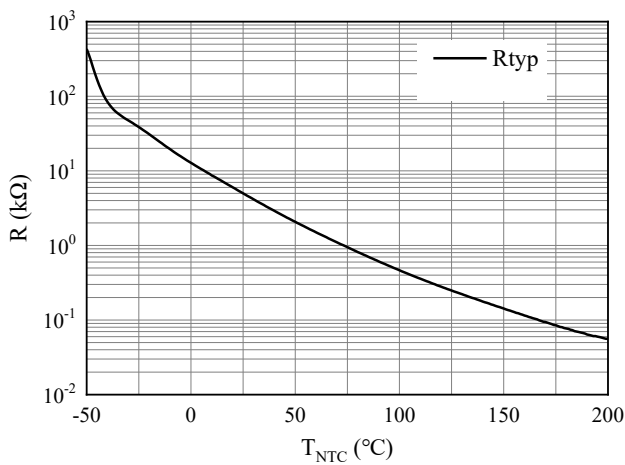
**Fig 8. Switching losses of IGBT**  
 $V_{GE} = \pm 15V$ ,  $I_C = 150A$ ,  $V_{CE} = 300V$



**Fig 9. Switching losses of Diode**  
 $R_{Gon} = 3.3\Omega$ ,  $V_{CE} = 300V$

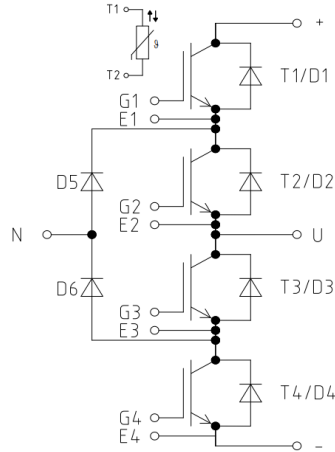


**Fig 10. Switching losses of Diode**  
 $I_F = 150A$ ,  $V_{CE} = 300V$



**Fig 11. NTC-Themistor-temperature characteristic**

**Circuit diagram**



**Package outlines**

