

3-Level NPC Inverter Module with 650V Trench Stop IGBTs

Features

- Electrical features

Neutral Point Clamped Three-level Inverter Module
 650V Field Stop IGBTs
 Low Inductive layout
 Solderable Pins/Press-fit Pins
 Thermistor
 Pb-Free, Halogen Free/BFR Free and RoHS Compliant

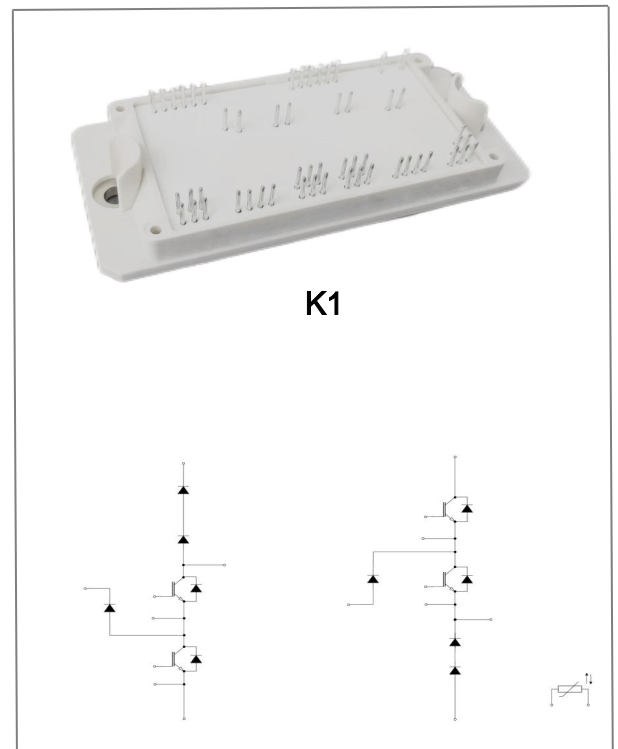

Typical Applications

Uninterruptable Power Supplies Systems
 Energy Storage System

Package Insulation coordination

Parameter	Symbol	Note or test condition	Values	Unit
Isolation test voltage	V _{ISOL}	DC Test Voltage (t _p =2s)	6.0	kV
		AC Test Voltage (t _p =60s)	2.5	
Creepage distance	d _{creep}		>12.7	mm
Clearance	d _{clear}		>12.7	mm
Comparative tracking index (electrical)	CTI		≥200	

Package Characteristic values

Parameter	Symbol	Note or test condition		Values			Unit
				Min.	Typ.	Max.	
Mounting torque for module mounting	M	-Mounting according to valid application note	M5, Screw	3		5	Nm
Weight	G				179.7		g

MAXIMUM RATINGS (Note 1)

Symbol	Rating	Value	Unit
--------	--------	-------	------

BUCK Switch

V_{CES}	Collector-Emitter Voltage	650	V
V_{GE}	Gate-Emitter Voltage	$\pm 20V$	V
I_C	Continuous Collector Current @ $T_c = 80^\circ C$ ($T_{JMAX} = 175^\circ C$)	300	A
I_{CRM}	Repetitive peak collector current (tp limited by T_{jmax})	900	A
P_{tot}	Maximum Power Dissipation @ $T_c = 80^\circ C$ ($T_{JMAX} = 175^\circ C$)	401	W
T_{JMAX}	Maximum Operating Junction Temperature	175	$^\circ C$

BUCK Diode

V_{RRM}	Peak Repetitive Reverse Voltage	650	V
I_F	Continuous Forward Current @ $T_c = 80^\circ C$ ($T_{JMAX} = 175^\circ C$)	300	A
I_{FRM}	Repetitive Peak Forward Current (tp limited by T_{jmax})	600	A
P_{tot}	Maximum Power Dissipation @ $T_c = 80^\circ C$ ($T_{JMAX} = 175^\circ C$)	539	W
T_{JMAX}	Maximum Operating Junction Temperature	175	$^\circ C$

BUCK Sw.Protection Diode

V_{RRM}	Peak Repetitive Reverse Voltage	650	V
I_F	Continuous Forward Current @ $T_c = 80^\circ C$ ($T_J = 175^\circ C$)	30	A
I_{FRM}	Repetitive Peak Forward Current (tp limited by T_{jmax})	60	A
P_{tot}	Maximum Power Dissipation @ $T_c = 80^\circ C$ ($T_{JMAX} = 175^\circ C$)	102	W
T_{JMAX}	Maximum Operating Junction Temperature	175	$^\circ C$

Symbol	Rating	Value	Unit
--------	--------	-------	------

Boost Switch

V_{CES}	Collector-Emitter Voltage	650	V
V_{GE}	Gate-Emitter Voltage	± 20	V
I_C	Continuous Collector Current @ $T_c = 80^\circ C$ ($T_{JMAX} = 175^\circ C$)	300	A
I_{CRM}	Repetitive peak collector current (tp limited by T_{jmax})	900	A
P_{tot}	Maximum Power Dissipation @ $T_c = 80^\circ C$ ($T_{JMAX} = 175^\circ C$)	409	W
T_{JMAX}	Maximum Operating Junction Temperature	175	$^\circ C$

Boost Diode

V_{RRM}	Peak Repetitive Reverse Voltage	650	V
I_F	Continuous Forward Current @ $T_c = 80^\circ C$ ($T_{JMAX} = 175^\circ C$)	220	A
I_{FRM}	Repetitive Peak Forward Current (tp limited by T_{jmax})	600	A
P_{tot}	Maximum Power Dissipation @ $T_c = 80^\circ C$ ($T_{JMAX} = 175^\circ C$)	448	W
T_{JMAX}	Maximum Operating Junction Temperature	175	$^\circ C$

Boost Sw.Protection Diode

V_{RRM}	Peak Repetitive Reverse Voltage	650	V
I_F	Continuous Forward Current @ $T_c = 80^\circ C$ ($T_J = 175^\circ C$)	30	A
I_{FRM}	Repetitive Peak Forward Current (tp limited by T_{jmax})	60	A
P_{tot}	Maximum Power Dissipation @ $T_c = 80^\circ C$ ($T_{JMAX} = 175^\circ C$)	103	W
T_{JMAX}	Maximum Operating Junction Temperature	175	$^\circ C$

THERMAL PROPERTIES

T_{stg}	Storage Temperature Range	-40 to 125	°C
T_{vjop}	Temperature under switching condition	-40 to 150	°C

Stresses exceeding those listed in the Maximum Ratings table may damage the device. If any of these limits are exceeded, device functionality should not be assumed, damage may occur and reliability may be affected.

1. Refer to ELECTRICAL CHARACTERISTICS, RECOMMENDED OPERATING RANGES and/or APPLICATION INFORMATION for Safe Operating parameters.

RECOMMENDED OPERATING RANGES

Symbol	Rating	Min	Max	Unit
T_J	Module Operating Junction Temperature	-40	175	°C

Functional operation above the stresses listed in the Recommended Operating Ranges is not implied. Extended exposure to stresses beyond the Recommended Operating Ranges limits may affect device reliability.

ELECTRICAL CHARACTERISTICS ($T_J = 25^\circ\text{C}$ unless otherwise noted)(AC test is three-level test mode)

Symbol	Parameter	Test Condition	Min	Typ	Max	Unit
--------	-----------	----------------	-----	-----	-----	------

BUCK Switch

I_{CES}	Collector-Emitter Cutoff Current	$V_{GE} = 0\text{ V}, V_{CE} = 650\text{ V}$	--	--	200	μA
$V_{CE(sat)}$	Collector-Emitter Saturation Voltage	$V_{GE} = 15\text{ V}, I_C = 300\text{ A}, T_J = 25^\circ\text{C}$	--	1.50	1.85	V
		$V_{GE} = 15\text{ V}, I_C = 300\text{ A}, T_J = 150^\circ\text{C}$	--	1.75	--	
$V_{GE(TH)}$	Gate-Emitter Threshold Voltage	$V_{GE} = V_{CE}, I_C = 3\text{ mA}$	4.2	4.8	5.4	V
I_{GES}	Gate Leakage Current	$V_{GE} = 20\text{ V}, V_{CE} = 0\text{ V}$	--	--	300	nA
$t_{d(on)}$	Turn-On Delay Time	$T_J = 25^\circ\text{C}$ $V_{CE} = 350\text{ V}, I_C = 200\text{ A}$ $V_{GE} = 15\text{ V}/-5\text{ V}, R_G = 10\Omega$	--	180	--	ns
t_r	Rise Time		--	40	--	
$t_{d(off)}$	Turn-off Delay Time		--	500	--	
t_f	Fall Time		--	30	--	
E_{on}	Turn-On Switching Loss per Pulse		--	2.37	--	
E_{off}	Turn Off Switching Loss per Pulse	--	6.99	--		
$t_{d(on)}$	Turn-On Delay Time	$T_J = 150^\circ\text{C}$ $V_{CE} = 350\text{ V}, I_C = 200\text{ A}$ $V_{GE} = 15\text{ V}/-5\text{ V}, R_G = 10\Omega$	--	170	--	ns
t_r	Rise Time		--	41	--	
$t_{d(off)}$	Turn-off Delay Time		--	550	--	
t_f	Fall Time		--	40	--	
E_{on}	Turn-on Switching Loss per Pulse		--	4.25	--	
E_{off}	Turn Off Switching Loss per Pulse	--	7.45	--		
C_{ies}	Input Capacitance	$V_{CE} = 25\text{ V}, V_{GE} = 0\text{ V}, f = 1\text{ Mhz}$	--	19300	--	nF
C_{oes}	Output Capacitance		--	616	--	
C_{res}	Reverse Transfer Capacitance		--	120	--	
Q_g	Total Gate Charge	$V_{CC} = 600\text{ V}, I_C = 300\text{ A}, V_{GE} = \pm 15\text{ V}$	--	588	--	nC
R_{thJC}	Thermal Resistance - Chip-to-Case	Thermal grease, Thickness = 2 Mil $\pm 2\%$, $\lambda_{paste} = 3.4\text{ W/mK}$	--	0.237	--	°C/W

BUCK Diode

V_F	Diode Forward Voltage	$I_F = 300\text{ A}, T_J = 25^\circ\text{C}$	--	1.30	1.80	V		
		$I_F = 300\text{ A}, T_J = 150^\circ\text{C}$	--	1.20	--			
I_R	Reverse leakage current	$V_r = 650\text{ V}$	--	--	15	μA		
t_{rr}	Reverse Recovery Time	$T_J = 25^\circ\text{C}$ $V_{CE} = 350\text{ V}, I_C = 200\text{ A}$ $R_G = 10\Omega$	--	37	--	ns		
Q_r	Reverse Recovery Charge		--	4.45	--		μC	
I_{RM}	Peak Reverse Recovery Current		--	179	--		A	
E_{rec}	Reverse recovered energy	$T_J = 150^\circ\text{C}$ $V_{CE} = 350\text{ V}, I_C = 200\text{ A}$ $R_G = 10\Omega$	--	2.55	--	mJ		
t_{rr}	Reverse Recovery Time		--	63.1	--		ns	
Q_r	Reverse Recovery Charge		--	10.53	--			μC
I_{RM}	Peak Reverse Recovery Current		--	252	--			A
E_{rec}	Reverse recovered energy		--	5.85	--			mJ
R_{thJC}	Thermal Resistance - Chip-to-Case	Thermal grease, Thickness = 2 Mil $\pm 2\%$, $\lambda_{paste} = 3.4\text{ W/mK}$	--	0.175	--	°C/W		

BUCK Sw.Protection Diode

V _F	Diode Forward Voltage	I _F = 30 A, T _J = 25°C	--	1.20	1.6	V
		I _F = 30 A, T _J = 150°C	--	1.05	--	
I _R	Reverse leakage current	V _r =650V	--	--	0.5	μA
R _{thJC}	Thermal Resistance – Chip-to-Case	Thermal grease, Thickness = 2 Mil ±2%, λ _{paste} =3.4 W/mK	--	0.935	--	°C/W

ELECTRICAL CHARACTERISTICS (T_J = 25°C unless otherwise noted)(AC test is three-level test mode)

Symbol	Parameter	Test Condition	Min	Typ	Max	Unit
--------	-----------	----------------	-----	-----	-----	------

Boost Switch

I _{CES}	Collector-Emitter Cutoff Current	V _{GE} = 0 V, V _{CE} = 650 V	--	--	200	μA	
V _{CE(sat)}	Collector-Emitter Saturation Voltage	V _{GE} = 15 V, I _C = 300 A, T _J = 25°C	--	1.45	1.80	V	
		V _{GE} = 15 V, I _C = 300 A, T _J = 150°C	--	1.70	--		
V _{GE(TH)}	Gate-Emitter Threshold Voltage	V _{GE} = V _{CE} , I _C = 3 mA	4.2	4.8	5.4	V	
I _{GES}	Gate Leakage Current	V _{GE} = 20 V, V _{CE} = 0 V	--	--	300	nA	
t _{d(on)}	Turn-On Delay Time	T _J = 25°C V _{CE} = 350 V, I _C = 200A V _{GE} = 15V/-5V, R _G = 10Ω	--	190	--	ns	
t _r	Rise Time		--	40	--		
t _{d(off)}	Turn-off Delay Time		--	510	--		
t _f	Fall Time		--	40	--		
E _{on}	Turn-On Switching Loss per Pulse		--	2.02	--		mJ
E _{off}	Turn Off Switching Loss per Pulse		--	8.62	--		
t _{d(on)}	Turn-On Delay Time		T _J = 150°C V _{CE} = 350 V, I _C = 200A V _{GE} = 15V/-5V, R _G = 10Ω	--	180		--
t _r	Rise Time	--		50	--		
t _{d(off)}	Turn-off Delay Time	--		560	--		
t _f	Fall Time	--		40	--		
E _{on}	Turn-on Switching Loss per Pulse	--		2.94	--	mJ	
E _{off}	Turn Off Switching Loss per Pulse	--		8.99	--		
C _{ies}	Input Capacitance	V _{CE} = 25 V, V _{GE} = 0 V, f = 1 Mhz		--	19300	--	nF
C _{oes}	Output Capacitance		--	616	--		
C _{res}	Reverse Transfer Capacitance		--	120	--		
Q _g	Total Gate Charge	V _{CC} = 600 V, I _C = 300 A, V _{GE} = ± 15 V	--	588	--	nC	
R _{thJC}	Thermal Resistance – Chip-to-Case	Thermal grease, Thickness = 2 Mil ±2%, λ _{paste} =3.4 W/mK	--	0.231	--	°C/W	

Boost Diode

V _F	Diode Forward Voltage	I _F = 300 A, T _J = 25°C	--	2.70	3.20	V
		I _F = 300 A, T _J = 150°C	--	2.50	--	
I _R	Reverse leakage current	V _r =1300V	--	--	15	μA
t _{rr}	Reverse Recovery Time	T _J = 25°C V _{CE} = 350 V, I _C = 200A R _G = 10Ω	--	47	--	ns
Q _r	Reverse Recovery Charge		--	3.8	--	μC
I _{RM}	Peak Reverse Recovery Current		--	127	--	A
E _{rec}	Reverse recovered energy		--	2.45	--	mJ
t _{rr}	Reverse Recovery Time		T _J = 150°C V _{CE} = 350 V, I _C = 200A R _G = 10Ω	--	71	--
Q _r	Reverse Recovery Charge	--		8.56	--	μC
I _{RM}	Peak Reverse Recovery Current	--		178	--	A
E _{rec}	Reverse recovered energy	--		5.85	--	mJ
R _{thJC}	Thermal Resistance – Chip-to-Case	Thermal grease, Thickness = 2 Mil ±2%, λ _{paste} =3.4 W/mK		--	0.212	--

Boost Sw.Protection Diode

V _F	Diode Forward Voltage	I _F = 30 A, T _J = 25°C	--	1.20	1.60	V
		I _F = 30 A, T _J = 150°C	--	1.05	--	
I _R	Reverse leakage current	V _r = 650V	--	--	0.5	μA
R _{thJC}	Thermal Resistance – Chip-to-Case	Thermal grease, Thickness = 2 Mil ±2%, λ _{paste} = 3.4 W/mK	--	0.915	--	°C/W

THERMISTOR PROPERTIES

R ₂₅	Nominal Resistance	T = 25°C	--	22	--	kΩ
R ₁₀₀	Nominal Resistance	T = 100°C	--	1486	--	Ω
R/R	Deviation of R ₂₅		-5	--	-5	%
PD	Power Dissipation		--	200	--	mW
	Power Dissipation Constant		--	2	--	mW/K
	B-value	B _(25/50) , tolerance ±1%	--	3950	--	K
	B-value	B _(25/100) , tolerance ±1%	--	3998	--	K

Product parametric performance is indicated in the Electrical Characteristics for the listed test conditions, unless otherwise noted.
Product performance may not be indicated by the Electrical Characteristics if operated under different conditions.

BUCK Switch Characteristics

Figure 1. Typical Output Characteristics
 $V_G = 15V$

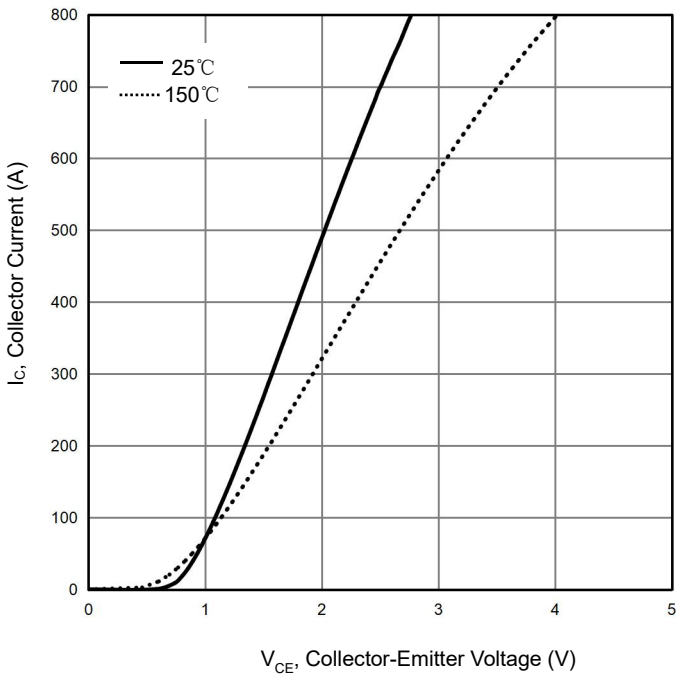

Figure 2. Typical Output Characteristics
 $T_j = 150^\circ C$

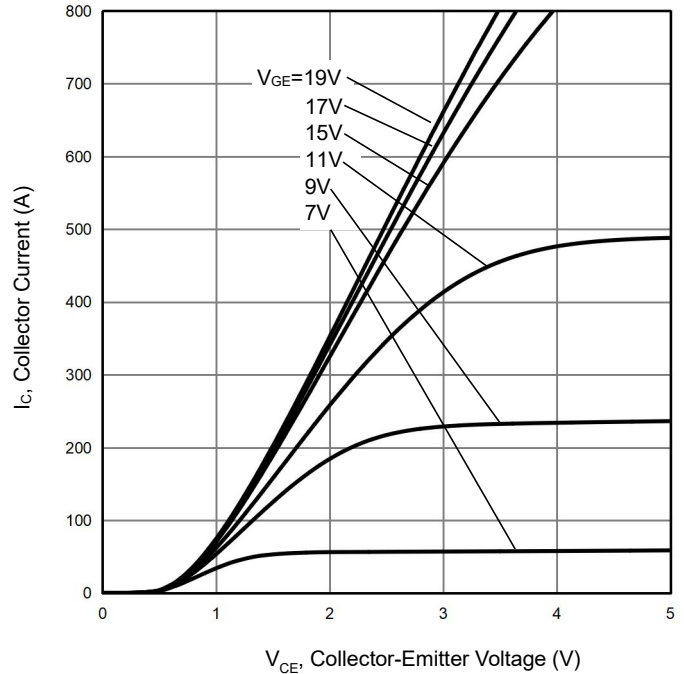

Figure 3. Typical Transfer Characteristics
 $V_{CE} = 20V$

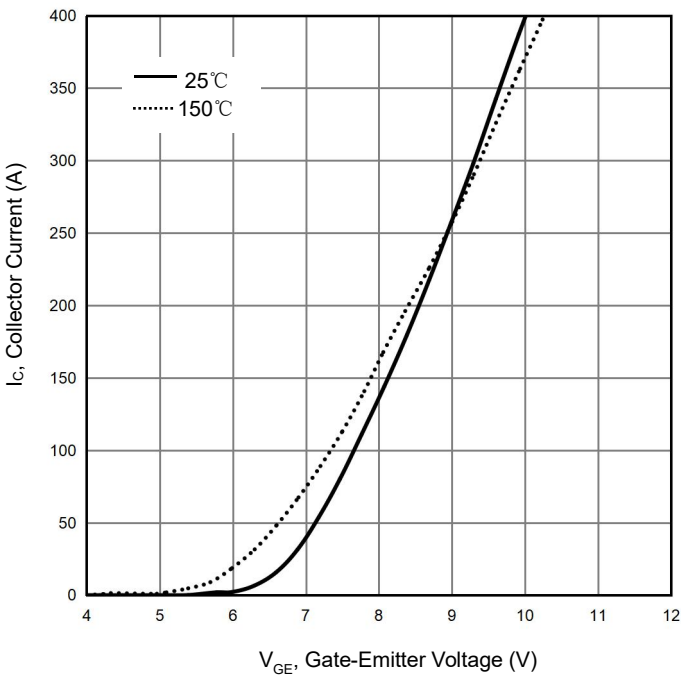
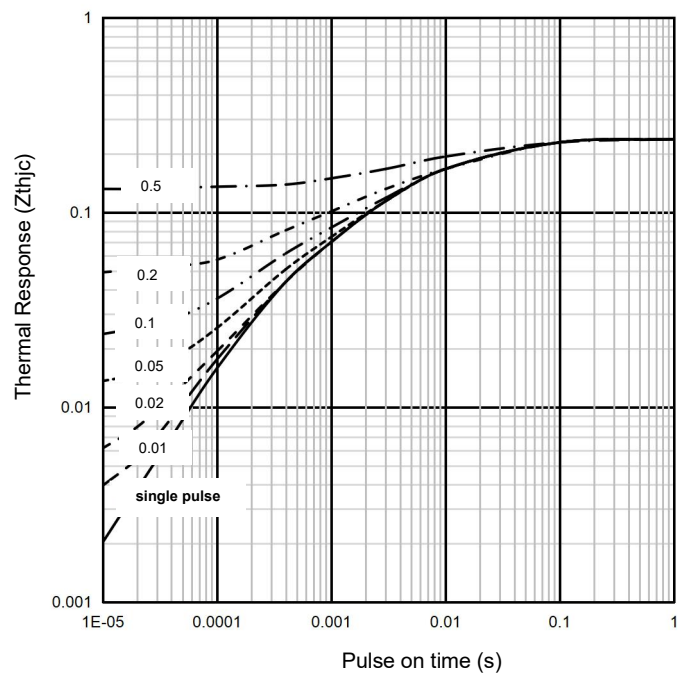

Figure 4. Transient thermal impedance as a function of pulse width



BUCK Switch Characteristics

Figure 5. Forward Bias Safe Operating Area

$T_C = 80^\circ\text{C}$, $T_J \leq T_{J \text{ max}}$, $V_G = 15\text{V}$

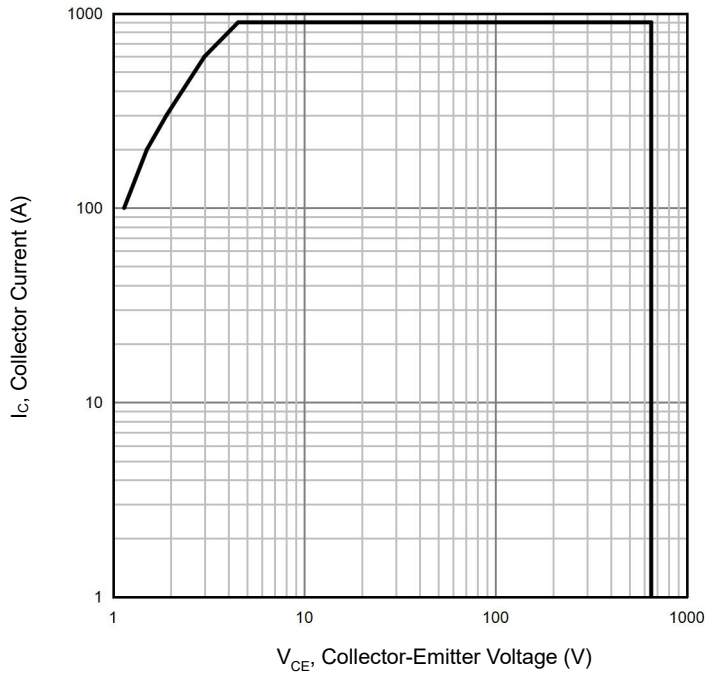

BUCK Diode Characteristics

Figure 6. Typical forward characteristics

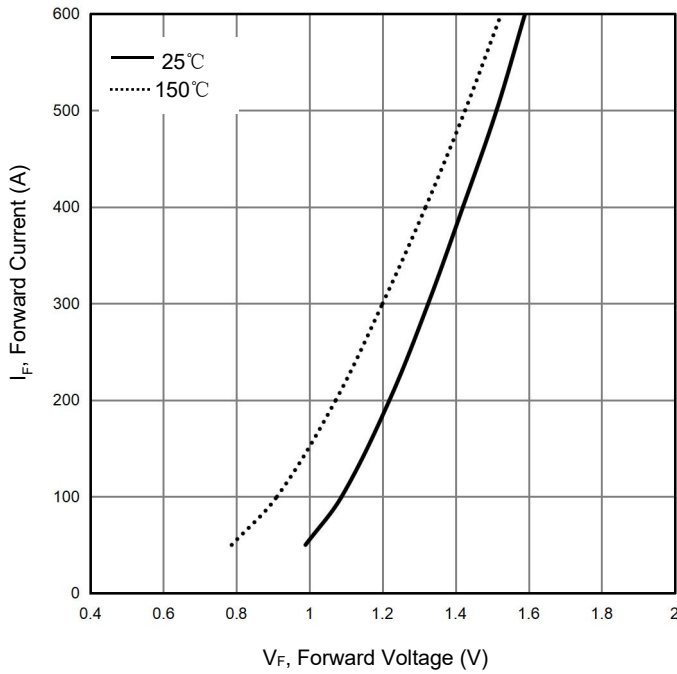
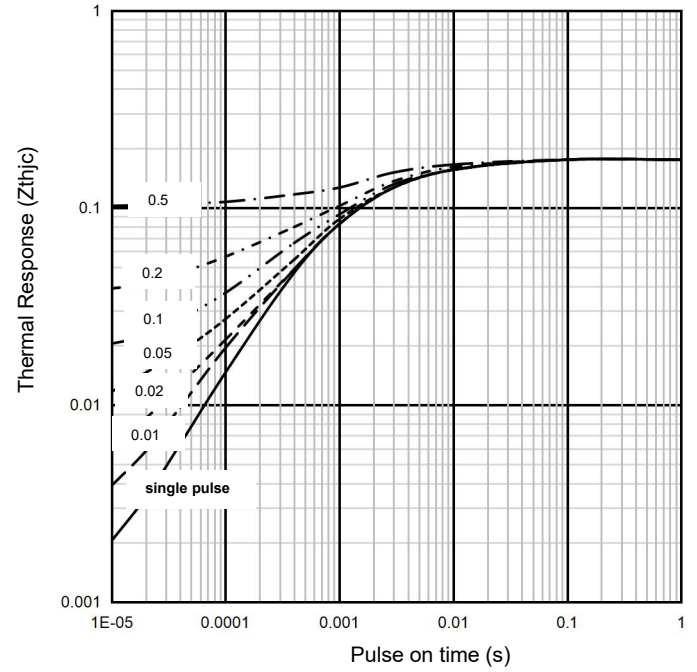

Figure 7. Transient thermal impedance as a function of pulse width



Buck Sw. Protection Diode Characteristics

Figure 8. Typical forward characteristics

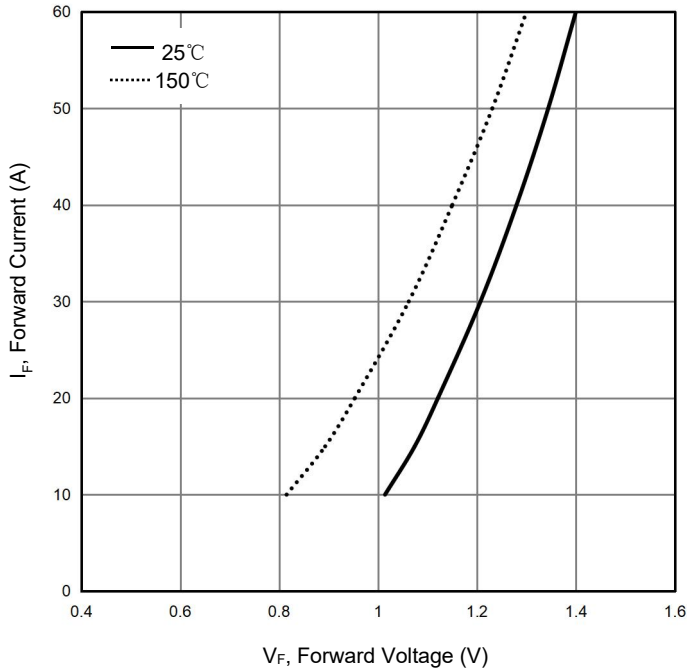
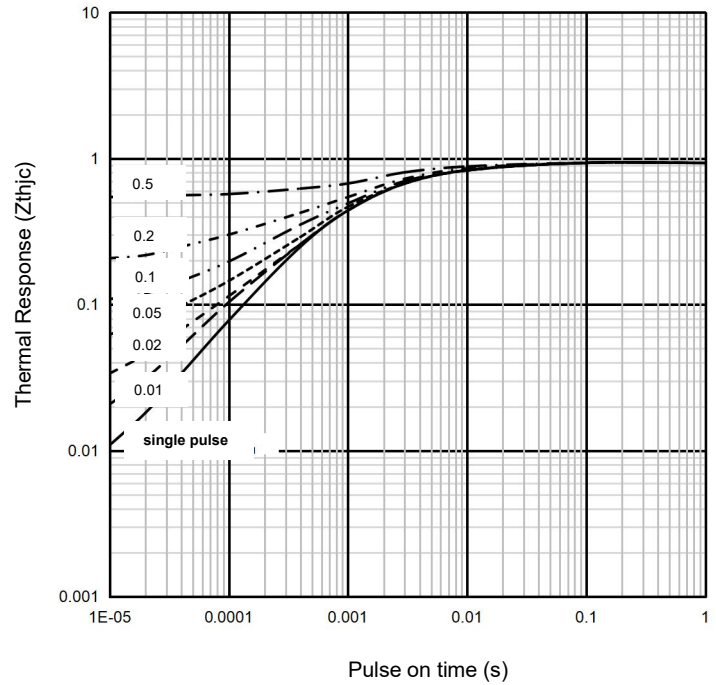

Figure 9. Transient thermal impedance as a function of pulse width



Boost Switch Characteristics

Figure 10. Typical Output Characteristics

$V_G = 15V$

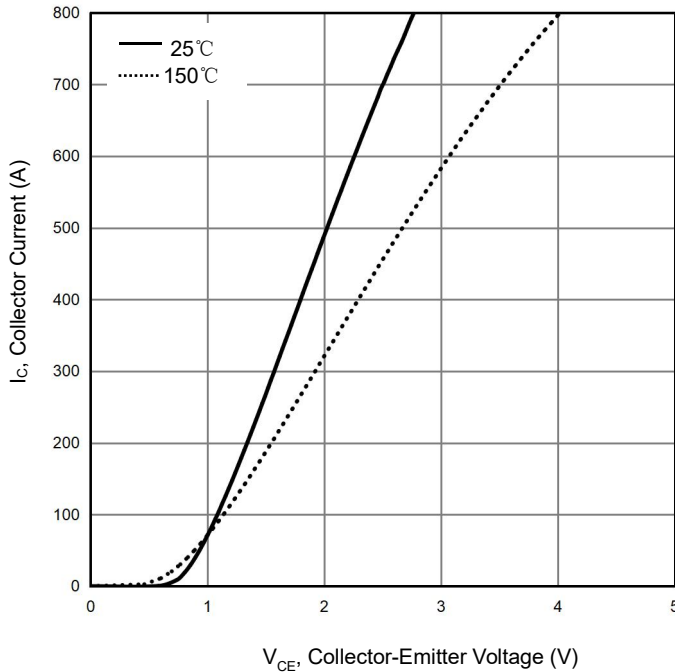

Figure 11. Typical Output Characteristics

$T_j = 150^\circ C$

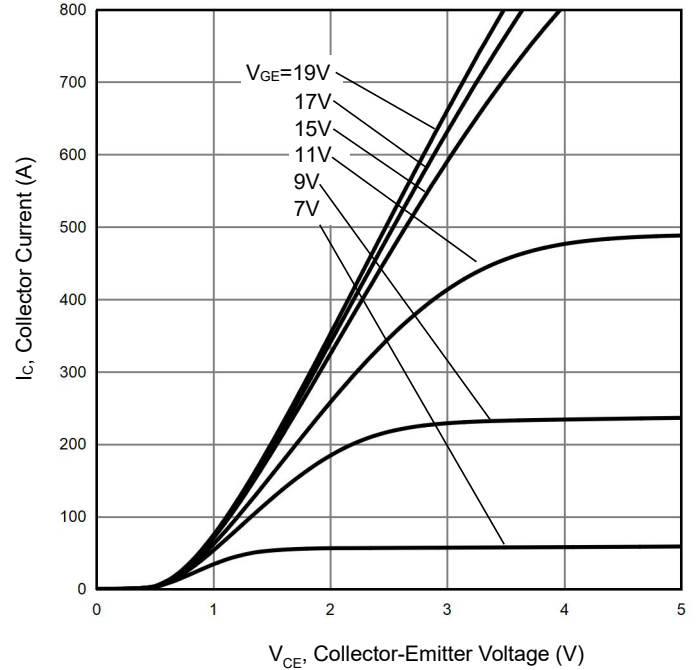

Figure 12. Typical Transfer Characteristics

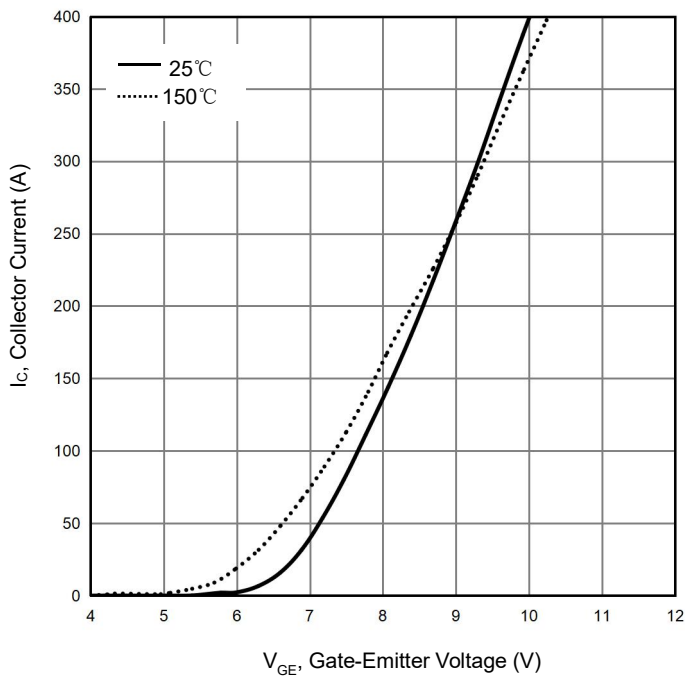
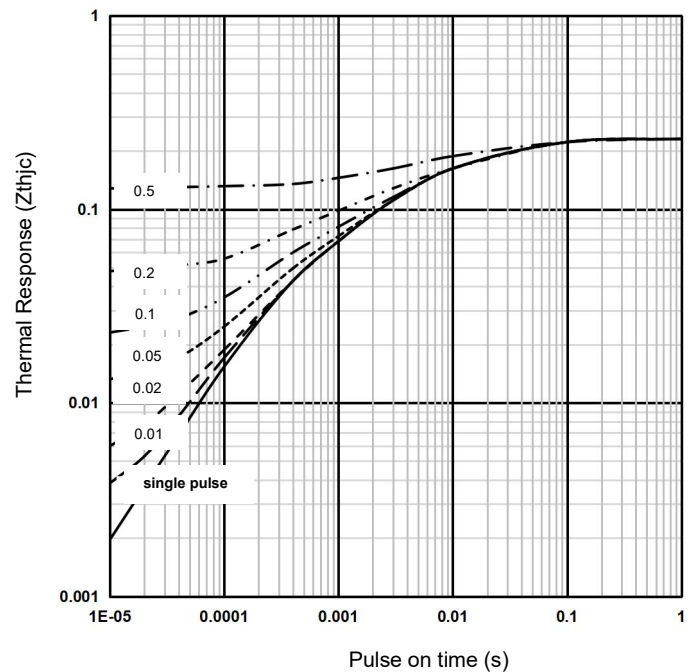

Figure 13. Transient thermal impedance as a function of pulse width



Boost Switch Characteristics

Figure 14. Forward Bias Safe Operating Area

$T_c = 80^\circ\text{C}$, $T_j \leq T_{j \text{ max}}$, $V_G = 15\text{V}$

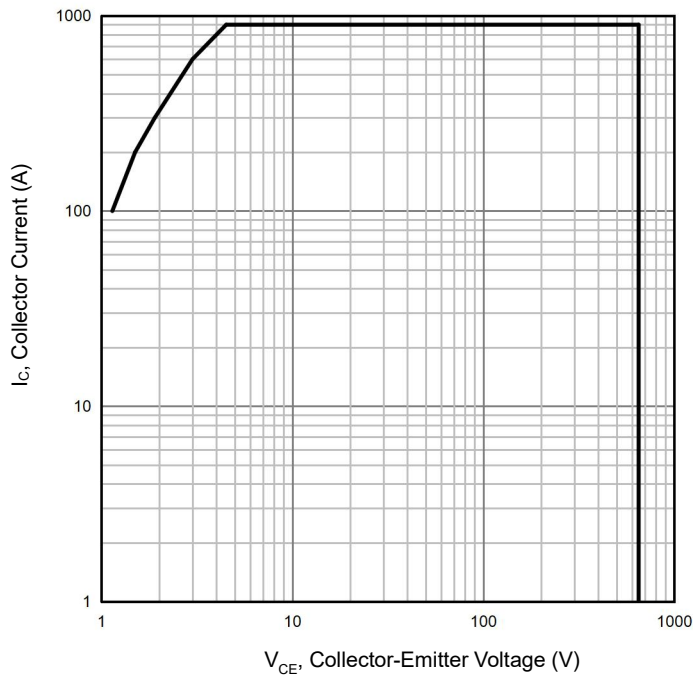

Boost Diode Characteristics

Figure 15. Typical forward characteristics

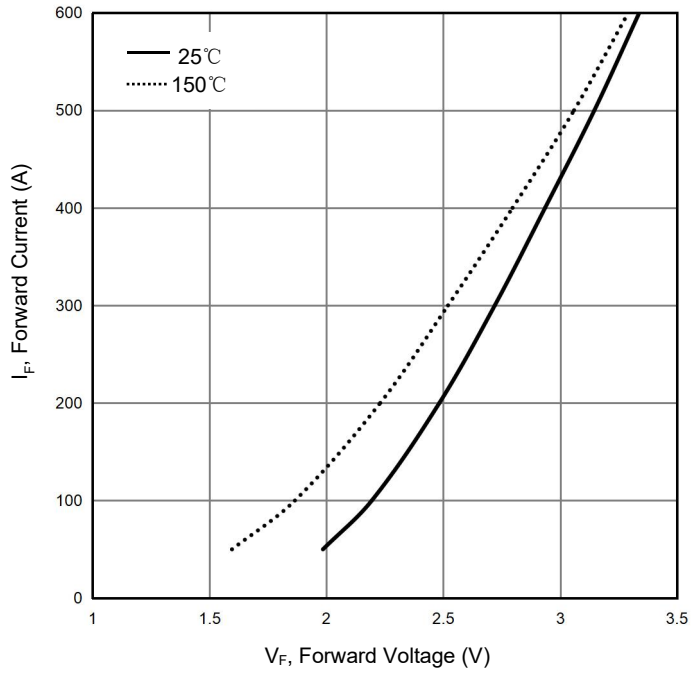
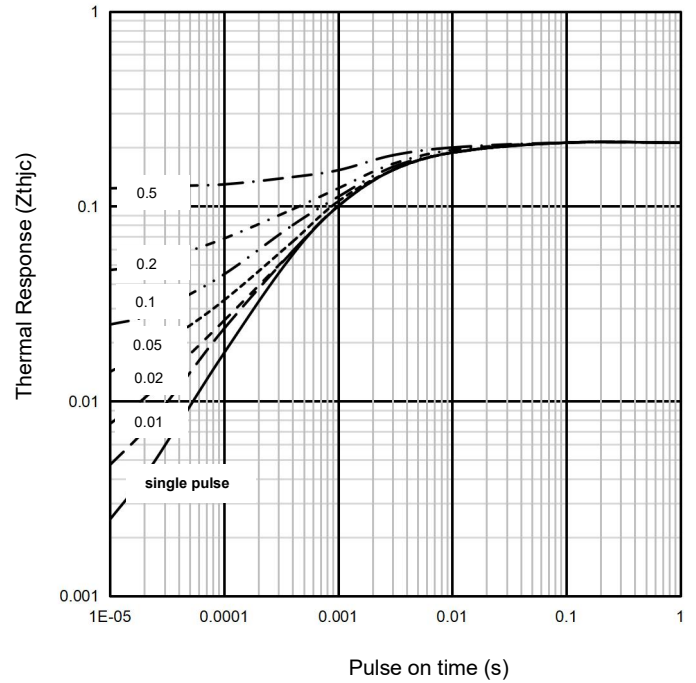

Figure 16. Transient thermal impedance as a function of pulse width



Boost Sw. Protection Diode Characteristics

Figure 17. Typical forward characteristics

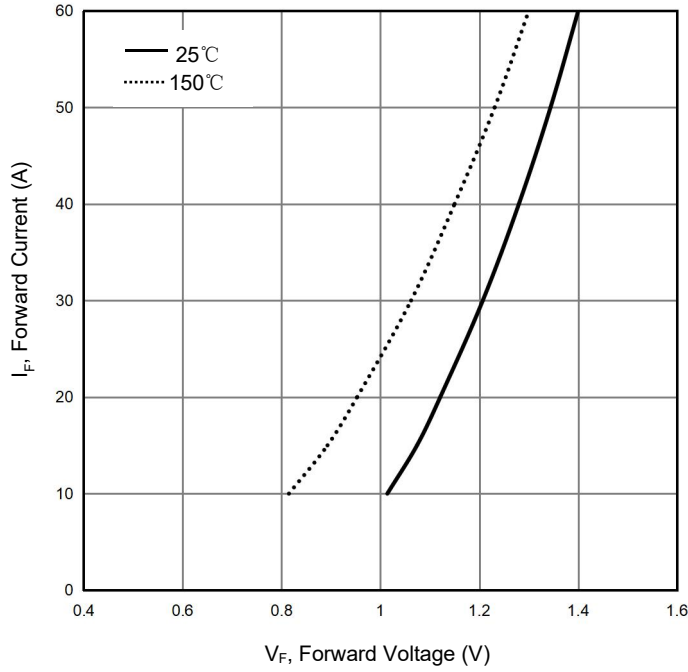
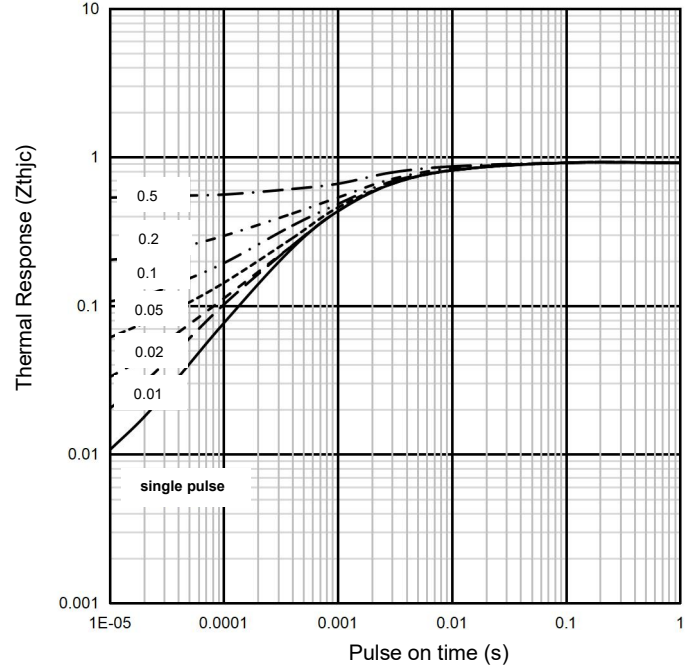
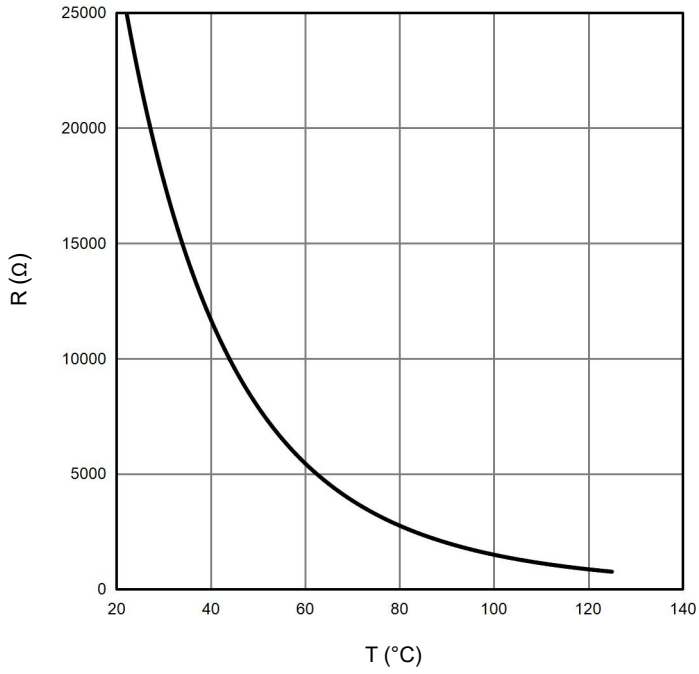

Figure 18. Transient thermal impedance as a function of pulse width



Thermistor Characteristics

Figure 19. Typical NTC characteristic as function of temperature



Buck Switching Characteristics

Figure 20. Typical switching energy losses as a function of collector current Characteristics

$V_{CE} = 350V, R_G = 15\Omega, V_{G(on)} = 15V, V_{G(off)} = -5V$

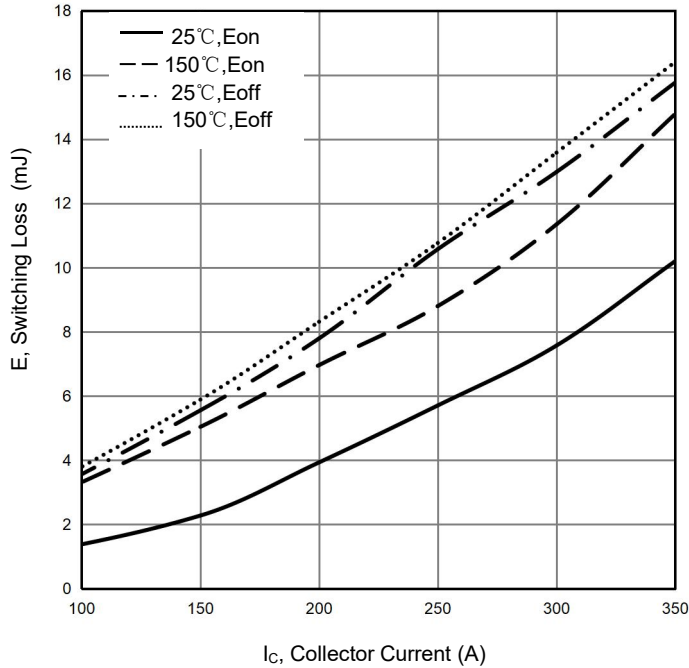

Figure 21. Typical switching energy losses as a function of IGBT turn on gate resistor

$V_{CE} = 350V, I_C = 200A, V_{G(on)} = 15V, V_{G(off)} = -5V$

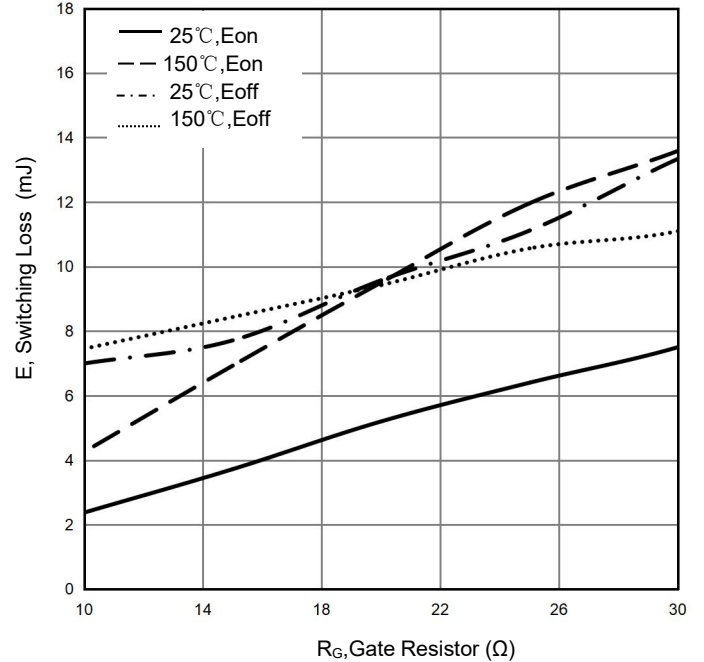

Figure 22. Typical reverse recovered energy loss as a function of collector current

$V_{CE} = 350V, R_G = 15\Omega, V_{G(on)} = 15V, V_{G(off)} = -5V$

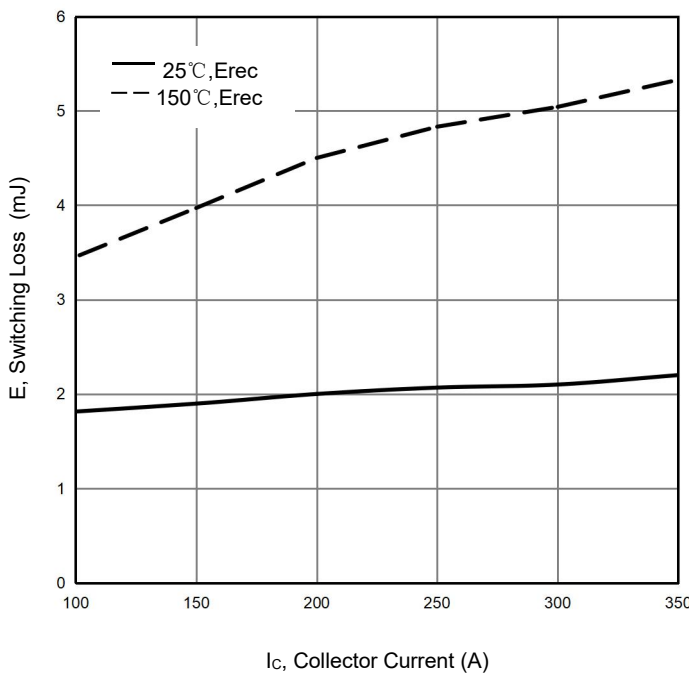
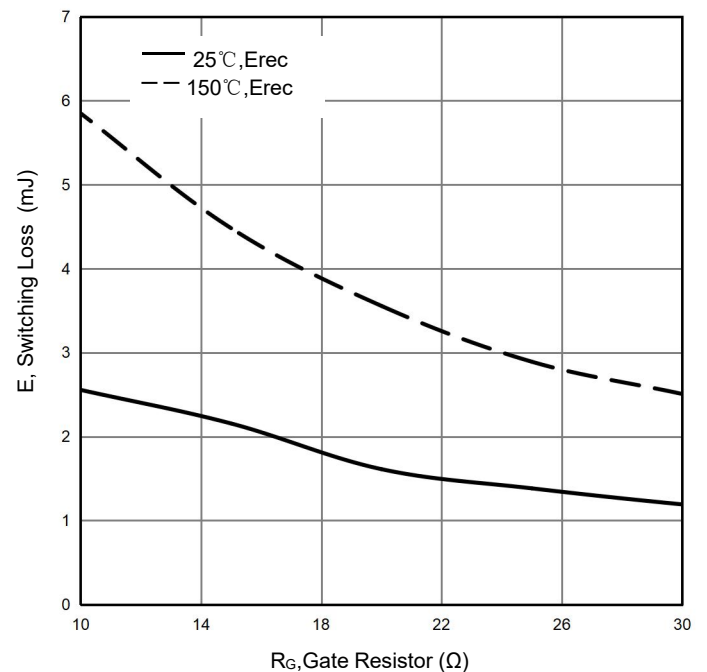

Figure 23. Typical reverse recovered energy loss as a function of IGBT turn on gate resistor

$V_{CE} = 350V, I_C = 200A, V_{G(on)} = 15V, V_{G(off)} = -5V$



Buck Switching Characteristics

Figure 24. Typical switching times as a function of collector current

$V_{CE} = 350V, R_G = 15\Omega, V_{G(on)} = 15V, V_{G(off)} = -5V, T_j = 150^\circ C$

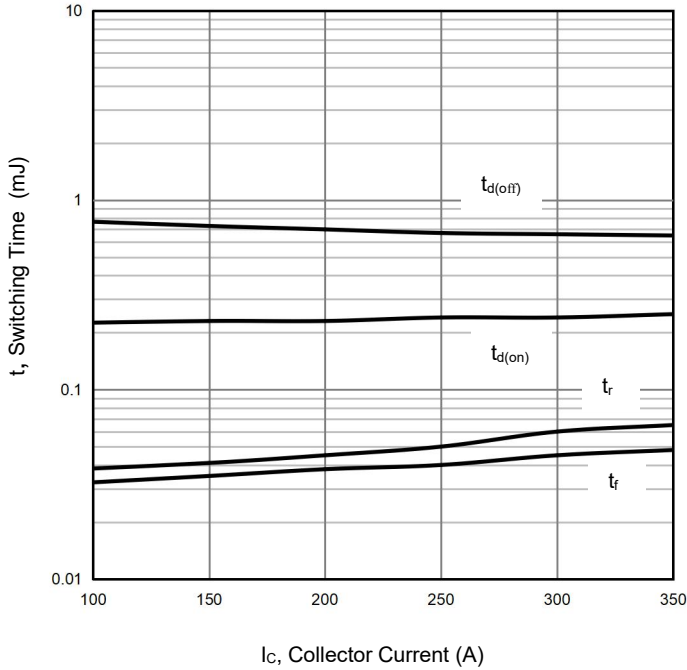

Figure 25. Typical switching times as a function of IGBT turn on gate resistor

$V_{CE} = 350V, I_c = 200A, V_{G(on)} = 15V, V_{G(off)} = -5V, T_j = 150^\circ C$

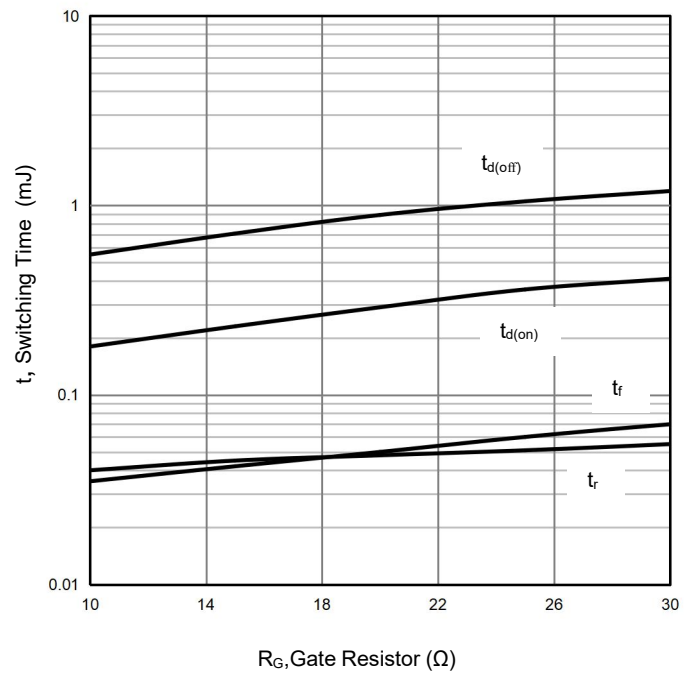

Figure 26. Typical reverse recovery time as a function of collector current

$V_{CE} = 350V, R_G = 15\Omega, V_{G(on)} = 15V, V_{G(off)} = -5V$

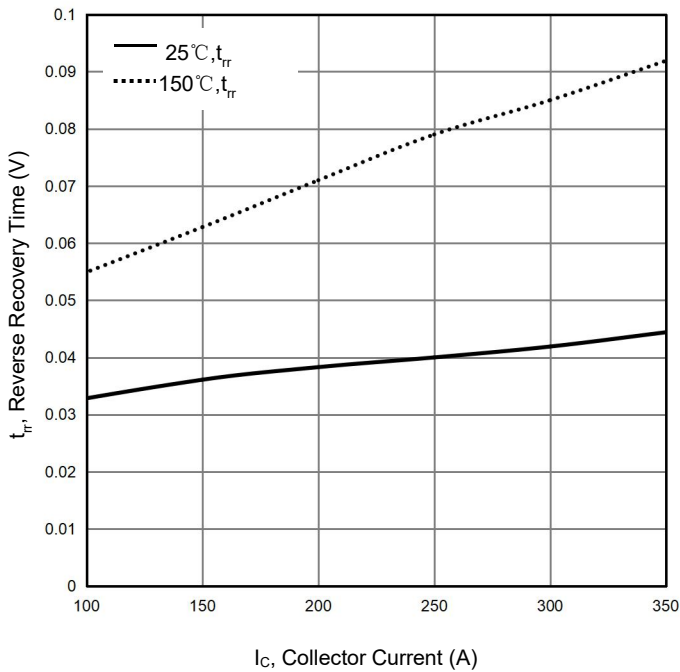
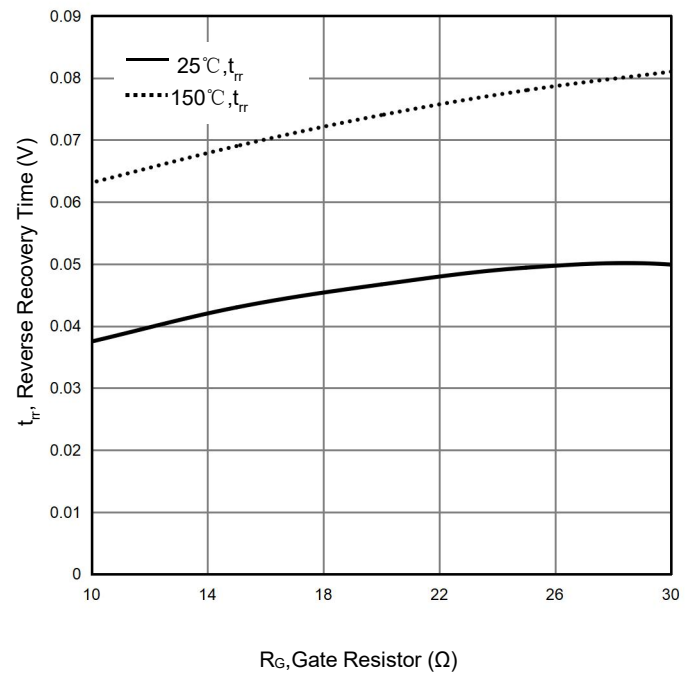

Figure 27. Typical reverse recovery time as a function of IGBT turn on gate resistor

$V_{CE} = 350V, I_c = 200A, V_{G(on)} = 15V, V_{G(off)} = -5V$



Buck Switching Characteristics

Figure 28. Typical recovered charge as a function of collector current

$V_{CE} = 350V, R_G = 15\Omega, V_{G(on)} = 15V, V_{G(off)} = -5V$

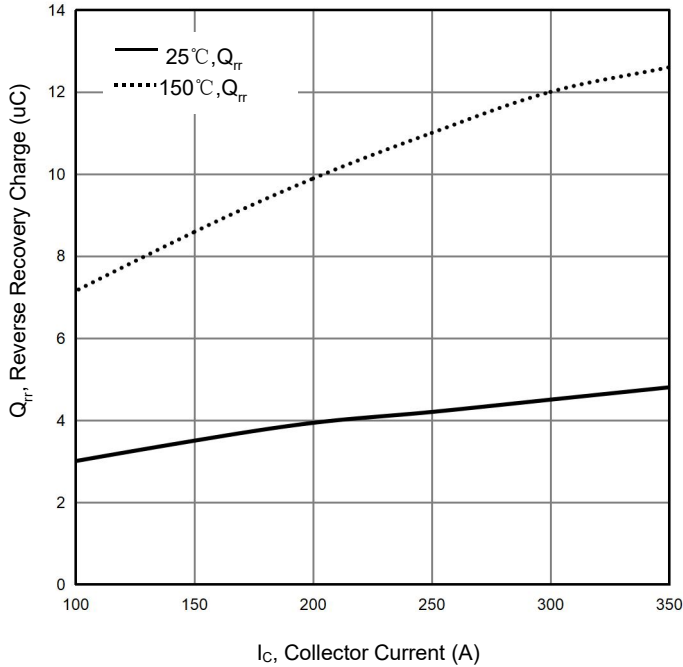

Figure 29. Typical recovered charge as a function of IGBT turn on gate resistor

$V_{CE} = 350V, I_C = 200A, V_{G(on)} = 15V, V_{G(off)} = -5V$

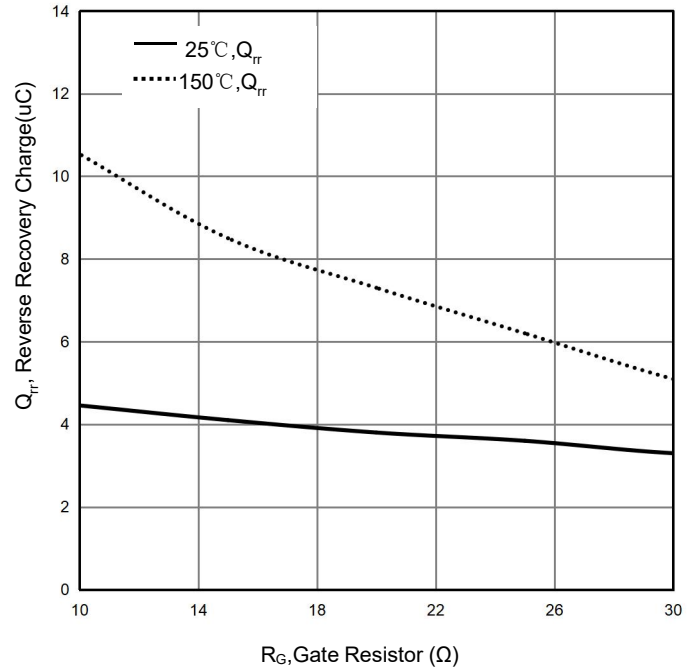

Figure 30. Typical peak reverse recovery current as a function of collector current

$V_{CE} = 350V, R_G = 15\Omega, V_{G(on)} = 15V, V_{G(off)} = -5V$

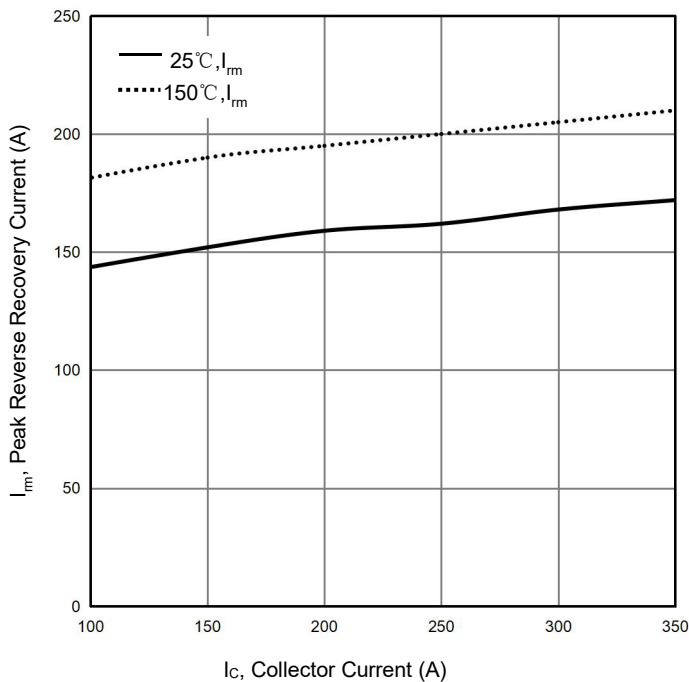
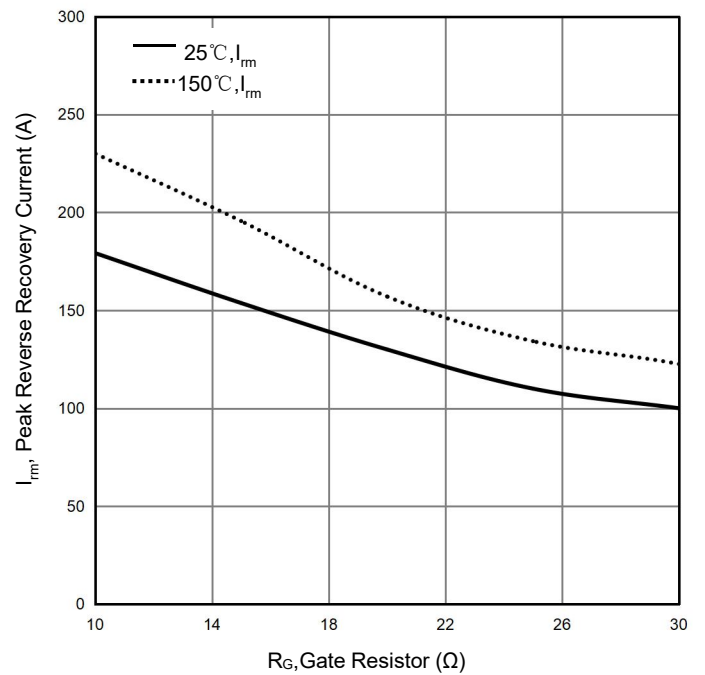

Figure 31. Typical peak reverse recovery current as a function of IGBT turn on gate resistor

$V_{CE} = 350V, I_C = 200A, V_{G(on)} = 15V, V_{G(off)} = -5V$



Buck Switching Characteristics

Figure 32. Reverse bias safe operating area

$V_{G(on)} = 15V, V_{G(off)} = -5V, T_j = 150^\circ C, R_G = 25\Omega$

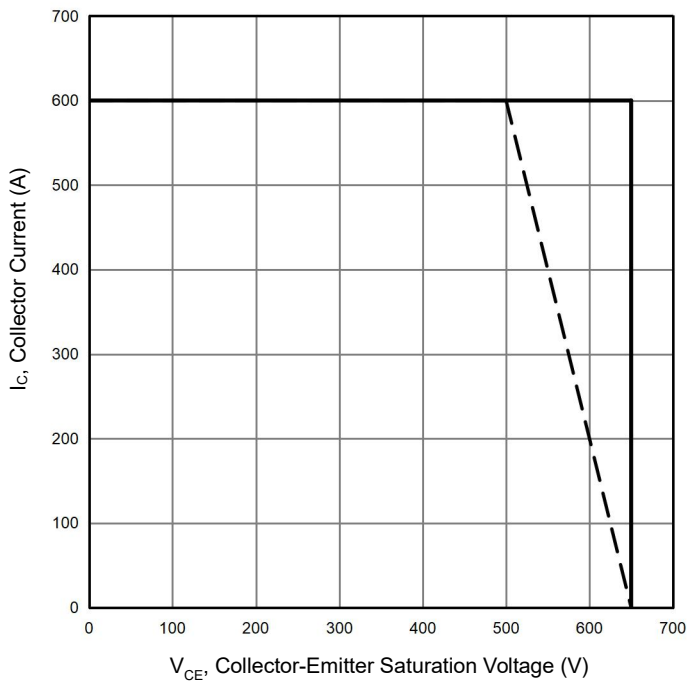

Boost Switching Characteristics

Figure 33. Typical switching energy losses as a function of collector current

$V_{CE} = 350V, R_G = 15\Omega, V_{G(on)} = 15V, V_{G(off)} = -5V$

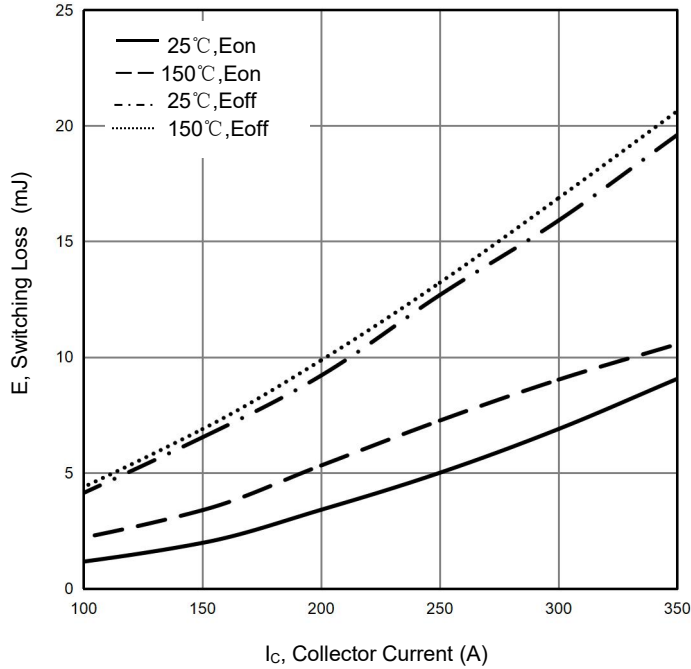

Figure 34. Typical switching energy losses as a function of IGBT turn on gate resistor

$V_{CE} = 350V, I_c = 200A, V_{G(on)} = 15V, V_{G(off)} = -5V$

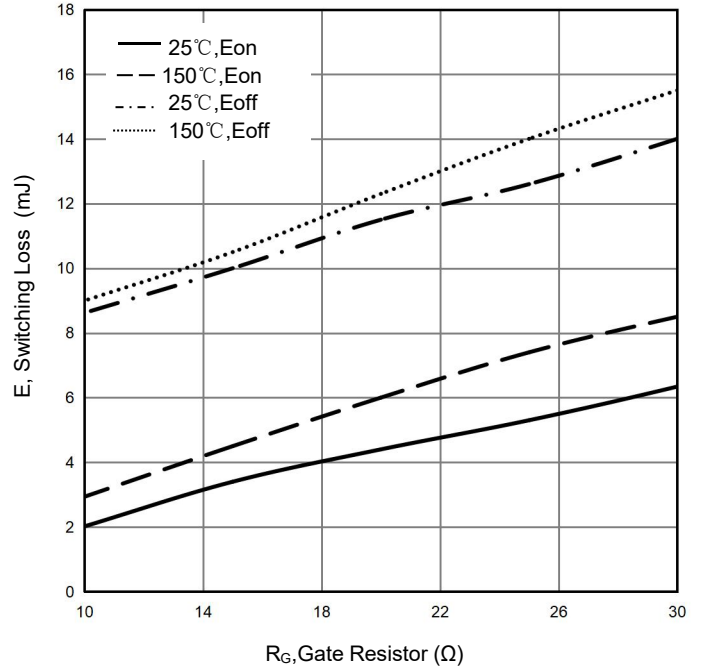

Figure 35. Typical reverse recovered energy loss as a function of collector current

$V_{CE} = 350V, R_G = 15\Omega, V_{G(on)} = 15V, V_{G(off)} = -5V$

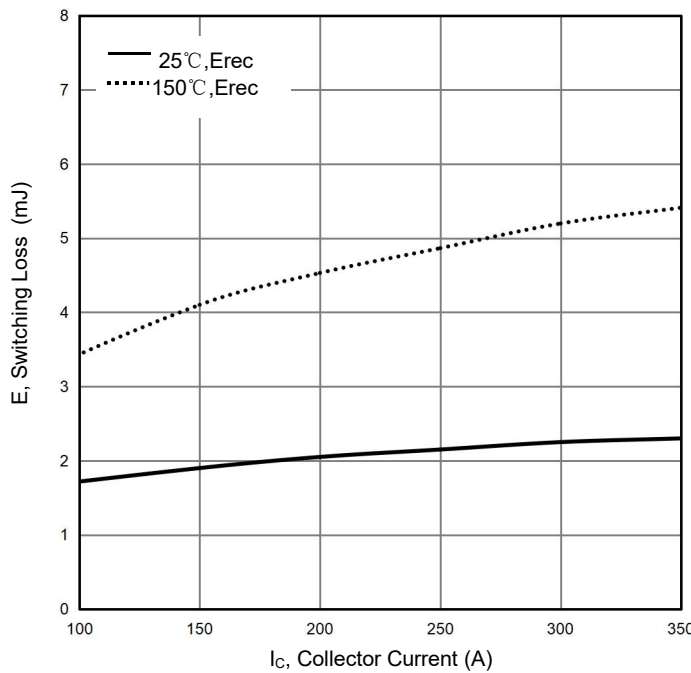
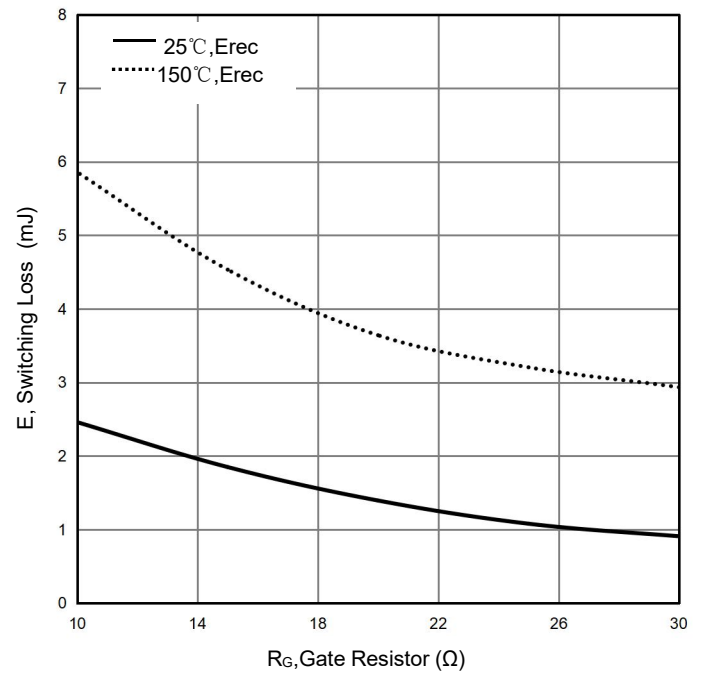

Figure 36. Typical reverse recovered energy loss as a function of IGBT turn on gate resistor

$V_{CE} = 350V, I_c = 200A, V_{G(on)} = 15V, V_{G(off)} = -5V$



Boost Switching Characteristics

Figure 37. Typical reverse recovery time as a function of collector current

$V_{CE} = 350V, R_G = 15\Omega, V_{G(on)} = 15V, V_{G(off)} = -5V, T_J = 150^\circ C$

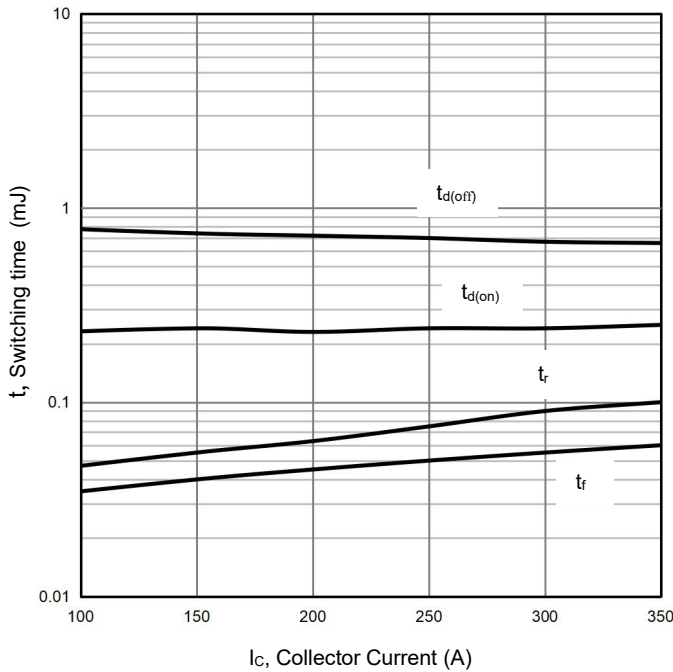

Figure 38. Typical reverse recovery time as a function of collector current

$V_{CE} = 350V, I_c = 200A, V_{G(on)} = 15V, V_{G(off)} = -5V, T_J = 150^\circ C$

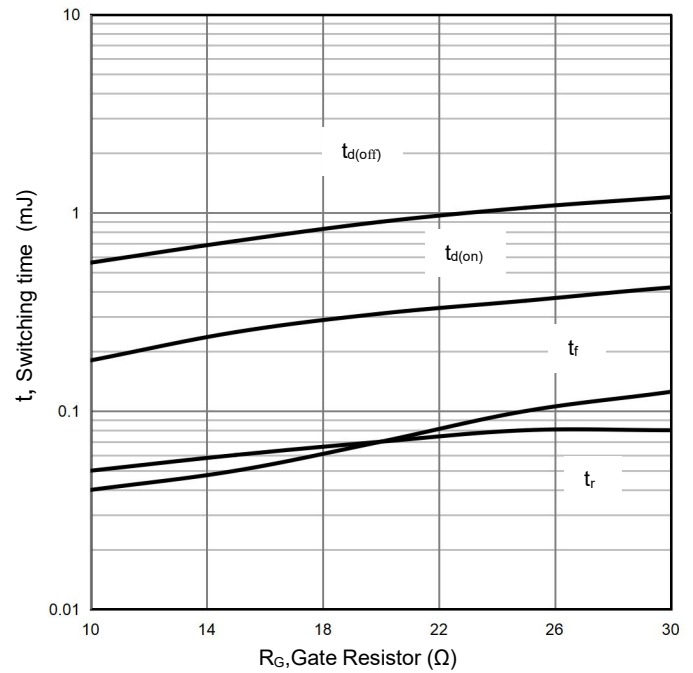

Figure 39. Typical reverse recovery time as a function of collector current

$V_{CE} = 350V, R_G = 15\Omega, V_{G(on)} = 15V, V_{G(off)} = -5V$

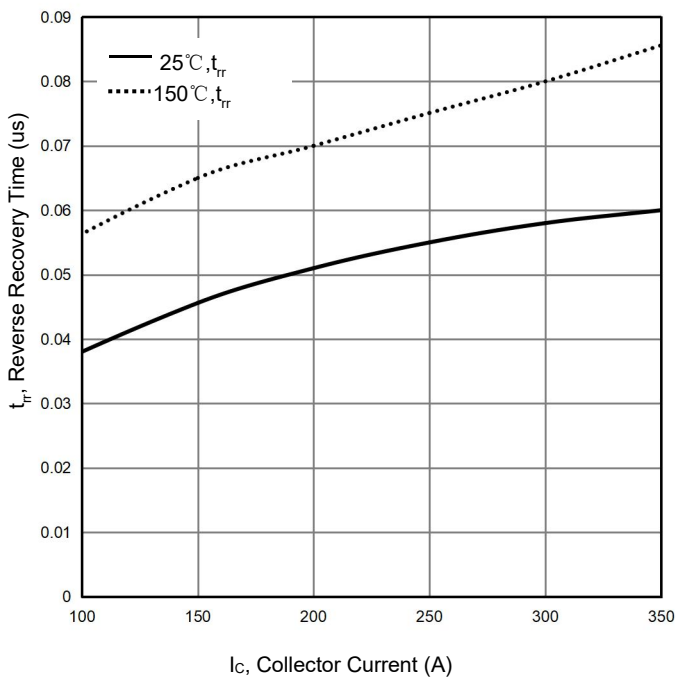
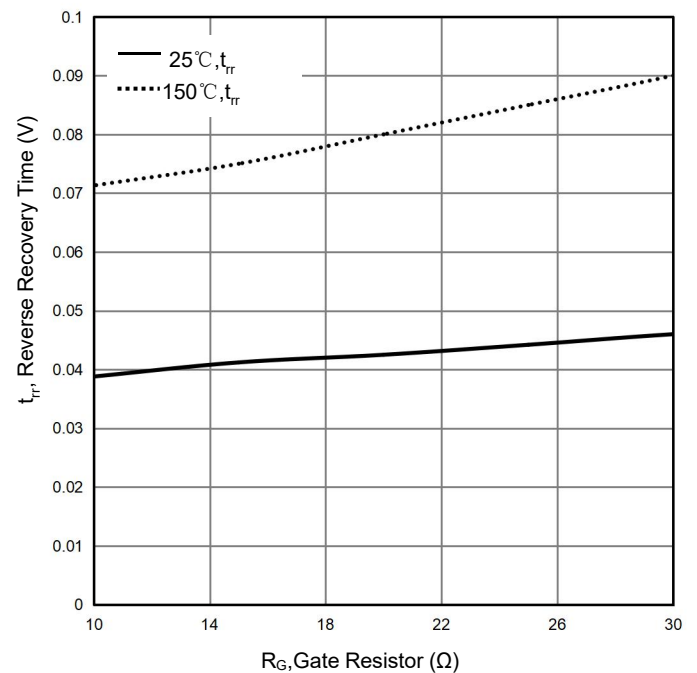

Figure 40. Typical reverse recovery time as a function of IGBT turn on gate resistor

$V_{CE} = 350V, I_c = 200A, V_{G(on)} = 15V, V_{G(off)} = -5V$



Boost Switching Characteristics

Figure 41. Typical recovered charge as a function of collector current

$V_{CE} = 350V, R_G = 15\Omega, V_{G(on)} = 15V, V_{G(off)} = -5V$

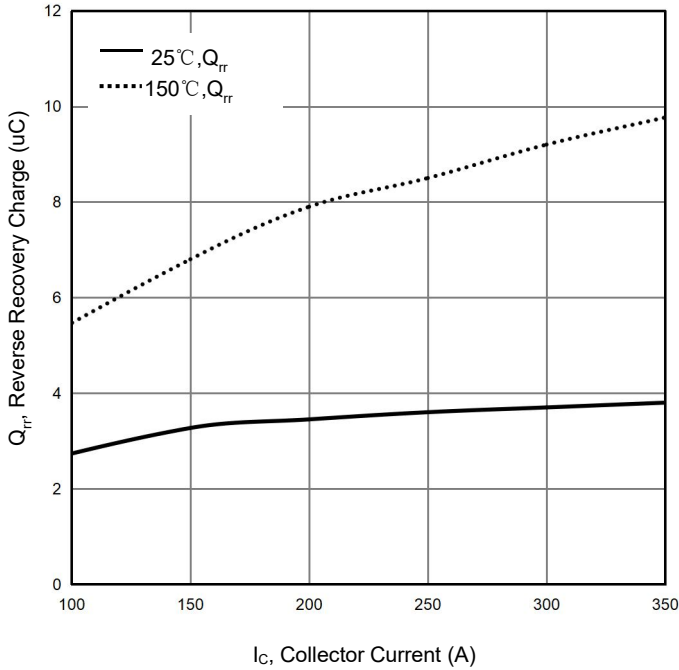

Figure 42. Typical recovered charge as a function of IGBT turn on gate resistor

$V_{CE} = 350V, I_C = 200A, V_{G(on)} = 15V, V_{G(off)} = -5V$

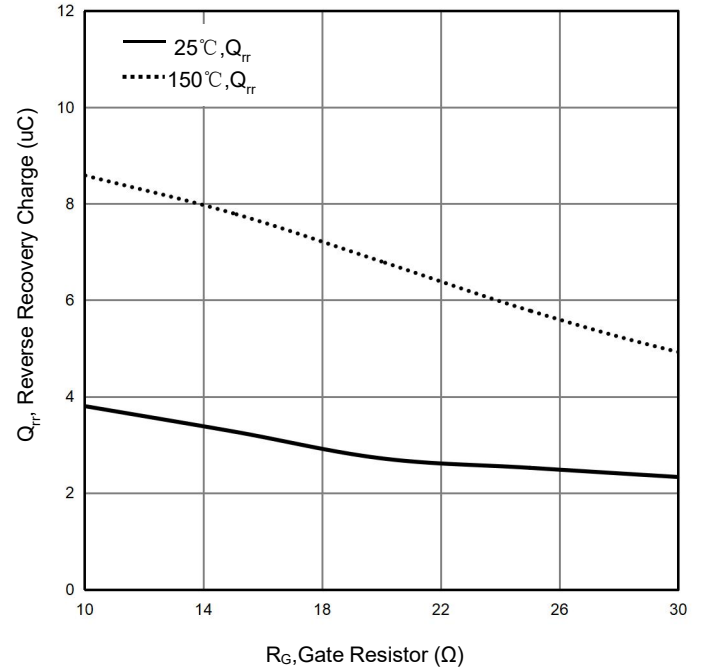

Figure 43. Typical peak reverse recovery current as a function of collector current

$V_{CE} = 350V, R_G = 15\Omega, V_{G(on)} = 15V, V_{G(off)} = -5V$

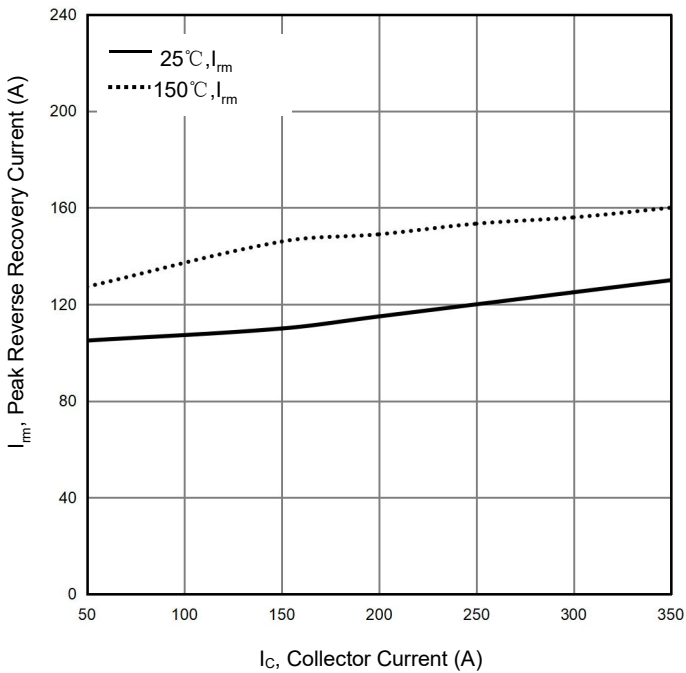
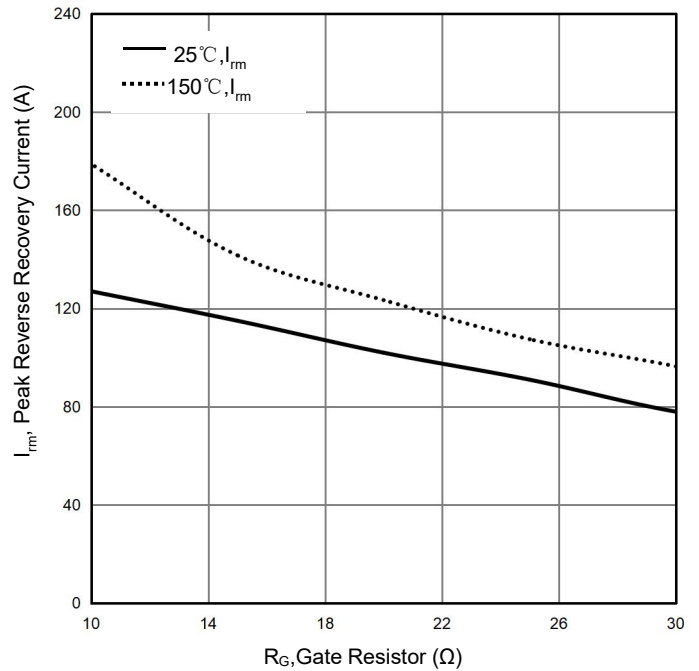

Figure 44. Typical peak reverse recovery current as a function of IGBT turn on gate resistor

$V_{CE} = 350V, I_C = 200A, V_{G(on)} = 15V, V_{G(off)} = -5V$



Boost Switching Characteristics

Figure 45.Reverse bias safe operating area

$V_{G(on)} = 15V, V_{G(off)} = -5V, T_j = 150^{\circ}C, R_G = 25\Omega$

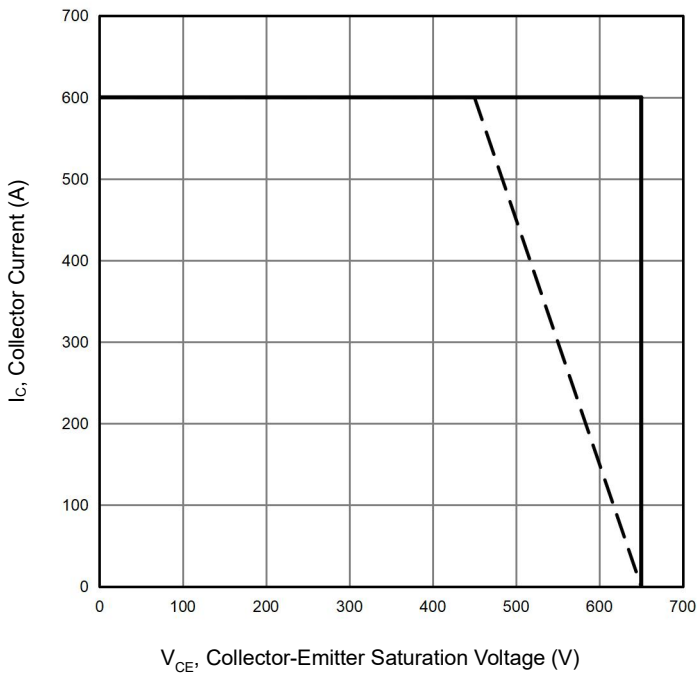

CIRCUIT DIAGRAM

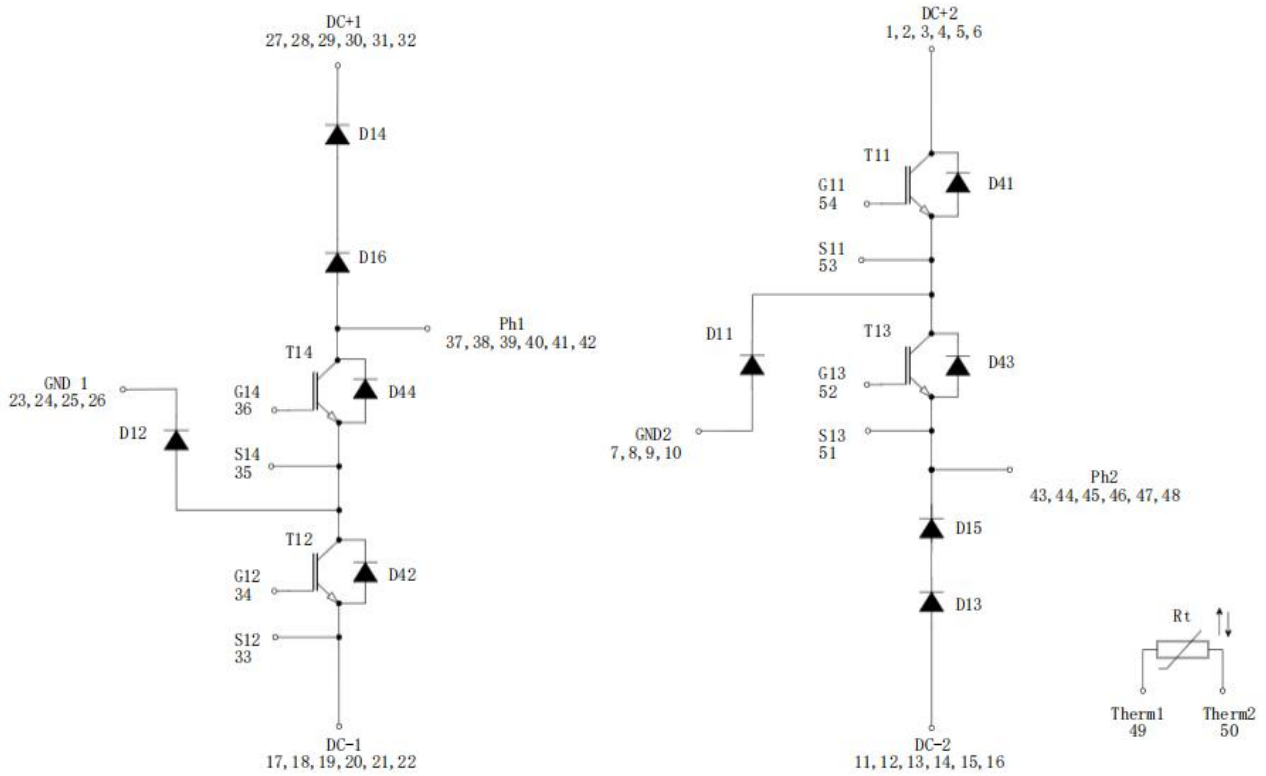

PACKAGE DIMENSIONS

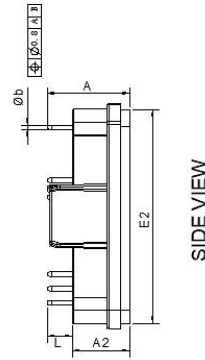
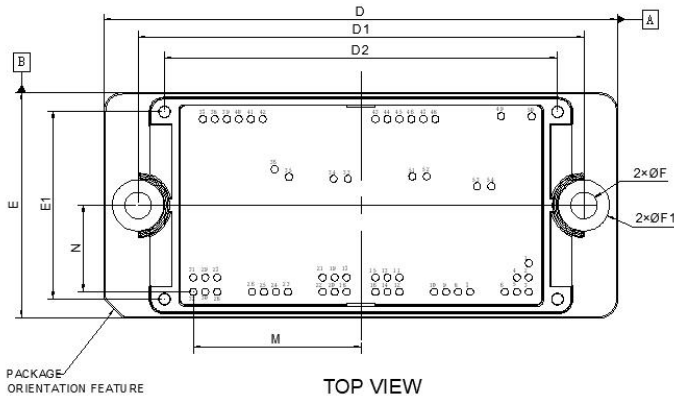

DIM	MILLIMETERS		
	MIN.	NOM.	MAX.
A	16.63	17.23	17.83
A1	4.50	4.70	4.90
A2	11.60	12.00	12.40
A3	16.40	16.70	17.00
b	0.95	1.00	1.05
D	106.80	107.20	107.60
D1	92.90	93.00	93.10
M	35 REF		
D2	81.80	82.00	82.20
D3	104.35	104.75	105.15
E	46.60	47.00	47.40
E1	38.80	39.00	39.20
N	18 REF		
E2	44.30	44.60	44.90
F	5.40	5.50	5.60
F1	10.70 REF		
L	5.03	5.23	5.43

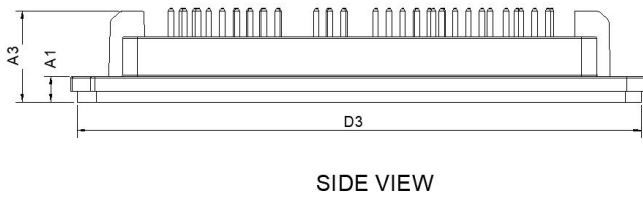

PIN	PIN POSITION	
	X	Y
1	70	6
2	70	3
3	70	0
4	67.5	3
5	67.5	0
6	65	0
7	57.75	0
8	55.25	0
9	52.75	0
10	50.25	0
11	43	3
12	43	0
13	40.5	3
14	40.5	0
15	38	3
16	38	0
17	32	3
18	32	0
19	29.5	3
20	29.5	0
21	27	3
22	27	0
23	19.75	0
24	17.25	0

PIN	PIN POSITION	
	X	Y
25	14.75	0
26	12.25	0
27	5	3
28	5	0
29	2.5	3
30	2.5	0
31	0	3
32	0	0
33	32.25	23.55
34	29.25	23.55
35	19.95	23.95
36	16.95	25.55
37	2	36
38	4.5	36
39	7	36
40	9.5	36
41	12	36
42	14.5	36
43	38	36
44	40.5	36
45	43	36
46	45.5	36
47	48	36
48	50.5	36

PIN	PIN POSITION	
	X	Y
49	64.2	36.6
50	70.6	36.55
51	45.7	24.05
52	48.7	24.05
53	59.2	22
54	62.2	22

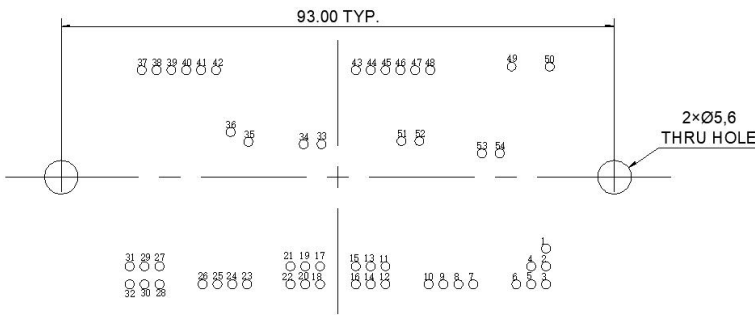

RECOMMENDED MOUNTING PATTERN