

A:  $V_{CES}=750V$ ,  $I_{C_{nom}}=550A$  /  $I_{CRM}=1100A$

B:  $V_{CES}=750V$ ,  $I_{C_{nom}}=820A$  /  $I_{CRM}=1640A$

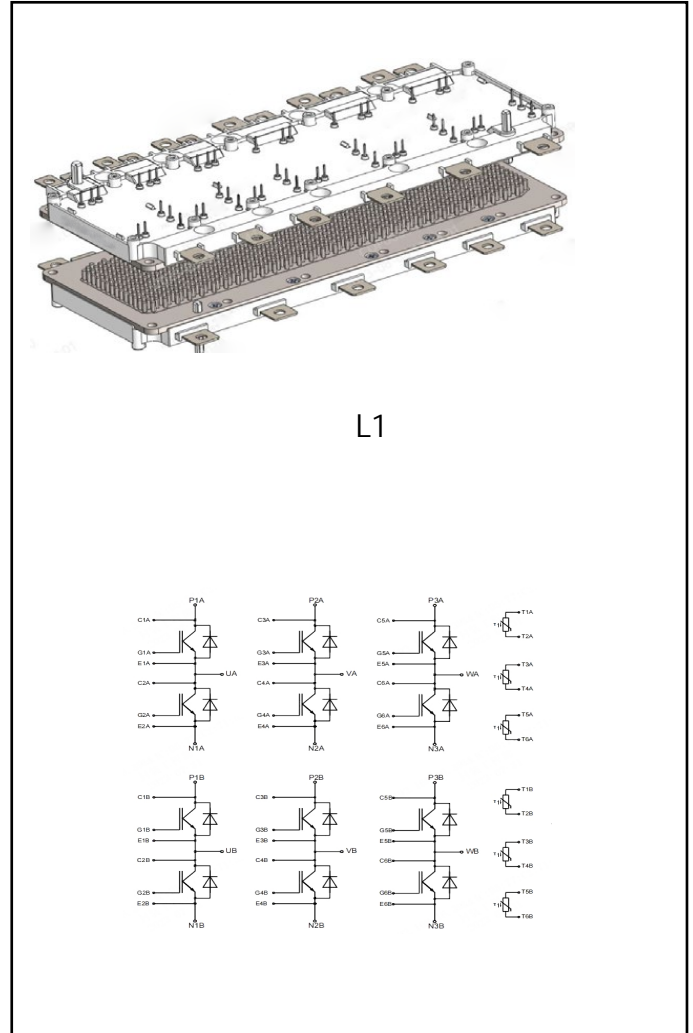

**Electrical characteristics :**

- 750V Trench / Field Stop process
- Low switching losses
- $V_{cesat}$  has a positive temperature coefficient
- Integrated NTC temperature sensor

**Applications:**

- Hybrid Electrical Vehicles(H)EV
- Motor Drives
- Automotive Applications

## IGBT, A

### Maximum Ratings

Parameter	Conditions	Symbol	Value	Unit
Collector-Emitter voltage	$T_{vj}=25^{\circ}\text{C}$	$V_{CES}$	750	V
Implemented forward current		$I_{CN}$	550	A
Continuous DC forward current			250	A
Repetitive peak collector current	$T_P=1\text{ms}$	$I_{CRM}$	1100	A
Total power dissipation	$T_F = 75^{\circ}\text{C}, T_{vj\text{ max}} = 175^{\circ}\text{C}$	$P_{tot}$	760	W
Gate emitter voltage	$T_{vj}=25^{\circ}\text{C}$	$V_{GE}$	$\pm 20$	V

### Characteristic Values

Parameter	Conditions	Symbol	Value			Unit	
			Min.	Typ.	Max.		
Collector-Emitter saturation voltage	$V_{GE}=15\text{V}, I_C=550\text{A}$ $V_{GE}=15\text{V}, I_C=550\text{A}$ $V_{GE}=15\text{V}, I_C=550\text{A}$	$T_{vj}=25^{\circ}\text{C}$ $T_{vj}=150^{\circ}\text{C}$ $T_{vj}=175^{\circ}\text{C}$	$V_{CESat}$	1.45 1.60 1.75	2.00	V	
Gate-Emitter Threshold Voltage	$I_C=8.5\text{mA}, V_{GE}=V_{CE}$	$T_{vj}=25^{\circ}\text{C}$	$V_{GE(th)}$	5.10	5.70	6.30	
Total Gate charge	$V_{CE} = 400\text{ V}, I_C = 300\text{ A}, V_{GE} = \pm 15\text{ V}$		$Q_G$	1580			nC
Internal gate resistor	$T_{vj} = 25^{\circ}\text{C}$		$R_{Gint}$	1.0			$\Omega$
Input capacitance			$C_{ies}$	30.0			nF
Output capacitance	$f=100\text{KHz}, V_{CE}=25\text{ V}, V_{GE}=0\text{ V}$		$C_{oes}$	2.00			
Reverse transfer capacitance	$T_{vj}=25^{\circ}\text{C}$		$C_{res}$	0.54			
Collector-emitter cut-off current	$V_{CE}=750\text{ V}, V_{GE}=0\text{ V}$	$T_{vj}=25^{\circ}\text{C}$ $T_{vj}=175^{\circ}\text{C}$	$I_{CES}$	4.5	1.0		mA
Gate-emitter leakage current	$V_{CE}=0\text{ V}, V_{GE}=20\text{ V}$	$T_{vj}=25^{\circ}\text{C}$	$I_{GES}$		300		nA
Turn-on delay time	$I_C=300\text{A}, V_{CE}=400\text{ V}$ $V_{GE}=\pm 15\text{ V}, R_G=4\Omega$ (inductive load)	$T_{vj}=25^{\circ}\text{C}$ $T_{vj}=150^{\circ}\text{C}$ $T_{vj}=175^{\circ}\text{C}$	$t_{d\text{ on}}$	125 122 126			ns

Rise time	$I_C=300A, V_{CE}=400V$ $V_{GE}=\pm 15V, R_G=4\Omega$ (inductive load)	$T_{vj}=25^\circ C$ $T_{vj}=150^\circ C$ $T_{vj}=175^\circ C$	$t_r$		77 77 80		ns
Turn-off delay time	$I_C=300A, V_{CE}=400V$ $V_{GE}=\pm 15V, R_G=4\Omega$ (电感负载) / (inductive load)	$T_{vj}=25^\circ C$ $T_{vj}=150^\circ C$ $T_{vj}=175^\circ C$	$t_{d\ off}$		265 297 315		ns
Fall time	$I_C=300A, V_{CE}=400V$ $V_{GE}=\pm 15V, R_G=4\Omega$ (inductive load)	$T_{vj}=25^\circ C$ $T_{vj}=150^\circ C$ $T_{vj}=175^\circ C$	$t_f$		275 346 300		ns
Turn-on energy loss per pulse	$I_C=300A, V_{CE}=400V$ $V_{GE}=\pm 15V, R_G=4\Omega$ $di/dt=3200A/\mu s(T_{vj}=150^\circ C)$ (inductive load)	$T_{vj}=25^\circ C$ $T_{vj}=150^\circ C$ $T_{vj}=175^\circ C$	$E_{on}$		8.05 10.1 11.5		mJ
Turn-off energy loss per pulse	$I_C=300A, V_{CE}=400V$ $V_{GE}=\pm 15V, R_G=4\Omega$ $dv/dt=3900V/\mu s(T_{vj}=150^\circ C)$ (inductive load)	$T_{vj}=25^\circ C$ $T_{vj}=150^\circ C$ $T_{vj}=175^\circ C$	$E_{off}$		17.0 21.0 22.5		mJ
Thermal resistance, junction to case	per IGBT		$R_{thJC}$		0.134		K/W
Temperature under switching conditions			$T_{vj\ op}$	-40		175	$^\circ C$

## Diode, A

### Maximum Ratings

Parameter	Conditions	Symbol	Value	Unit
Repetitive peak reverse voltage	$T_{vj}=25^\circ C$	$V_{RRM}$	750	V
Implemented forward current		$I_{FN}$	550	A
Continuous DC forward current		$I_F$	230	A
Repetitive peak forward current	$t_p=1ms$	$I_{FRM}$	1100	A

### Characteristic Values

Parameter	Conditions	Symbol	Value			Unit
			Min.	Typ.	Max.	
Forward voltage	$I_F=550A, V_{GE}=0V$	$V_F$		1.81	2.20	V
	$I_F=550A, V_{GE}=0V$			1.95		
	$I_F=550A, V_{GE}=0V$			1.98		

Peak reverse recovery current	$I_F = 300A,$ $-diF/dt = 3200A/\mu s (T_{vj} = 150^\circ C)$ $V_R = 400V, V_{GE} = -15V$	$T_{vj} = 25^\circ C$ $T_{vj} = 150^\circ C$ $T_{vj} = 175^\circ C$	$I_{RM}$		135 190 300		A
Reverse Recovery Time	$I_F = 300A,$ $-diF/dt = 3200A/\mu s (T_{vj} = 150^\circ C)$ $V_R = 400V, V_{GE} = -15V$	$T_{vj} = 25^\circ C$ $T_{vj} = 150^\circ C$ $T_{vj} = 175^\circ C$	$T_{rr}$		110 225 255		ns
Recovered charge	$I_F = 300A,$ $-diF/dt = 3200A/\mu s (T_{vj} = 150^\circ C)$ $V_R = 400V, V_{GE} = -15V$	$T_{vj} = 25^\circ C$ $T_{vj} = 150^\circ C$ $T_{vj} = 175^\circ C$	$Q_{rr}$		8.38 20.1 22.7		$\mu C$
Reverse recovered energy	$I_F = 300A,$ $-diF/dt = 3200A/\mu s (T_{vj} = 150^\circ C)$ $V_R = 400V, V_{GE} = -15V$	$T_{vj} = 25^\circ C$ $T_{vj} = 150^\circ C$ $T_{vj} = 175^\circ C$	$E_{rec}$		1.87 5.63 6.03		mJ
Thermal resistance, junction to case	每个二极管 / per diode		$R_{thJC}$		0.178		K/W
Temperature under switching conditions			$T_{vj op}$	-40		175	$^\circ C$

## IGBT, B

### Maximum Ratings

Parameter	Conditions	Symbol	Value	Unit
Collector-Emitter voltage	$T_{vj} = 25^\circ C$	$V_{CES}$	750	V
Implemented forward current		$I_{CN}$	820	A
Continuous DC forward current	$T_F = 80^\circ C, T_{vj max} = 175^\circ C$	$I_{C nom}$	450	A
Repetitive peak collector current	$T_P = 1ms$	$I_{CRM}$	1640	A
Total power dissipation	$T_F = 75^\circ C, T_{vj max} = 175^\circ C$	$P_{tot}$	760	W
Gate emitter voltage	$T_{vj} = 25^\circ C$	$V_{GE}$	$\pm 20$	V

### Characteristic Values

Parameter	Conditions	Symbol	Value			Unit
			Min.	Typ.	Max.	

Collector-Emitter saturation voltage	$V_{GE}=15V, I_C=820A$ $V_{GE}=15V, I_C=820A$ $V_{GE}=15V, I_C=820A$	$T_{vj}=25^{\circ}C$ $T_{vj}=150^{\circ}C$ $T_{vj}=175^{\circ}C$	$V_{CEsat}$		1.45 1.60 1.75	2.00	V
Gate-Emitter Threshold Voltage	$I_C=9.6mA, V_{GE}=V_{CE}$	$T_{vj}=25^{\circ}C$	$V_{GE(th)}$	5.15	5.75	6.35	
Total Gate charge	$V_{CE} = 400 V, I_C = 450 A, V_{GE} = \pm 15 V$		$Q_G$		2300		nC
Internal gate resistor	$T_{vj}=25^{\circ}C$		$R_{gint}$		0.7		$\Omega$
Input capacitance	$f=100KHz, V_{CE}=25 V, V_{GE}=0 V$ $T_{vj}=25^{\circ}C$		$C_{ies}$		44.1		nF
Output capacitance			$C_{oes}$		3.03		
Reverse transfer capacitance			$C_{res}$		0.80		
Collector-emitter cut-off current	$V_{CE}=750V, V_{GE}=0 V$	$T_{vj}=25^{\circ}C$ $T_{vj}=175^{\circ}C$	$I_{CES}$		10	1.0	mA
Gate-emitter leakage current	$V_{CE}=0 V, V_{GE}=20 V$	$T_{vj}=25^{\circ}C$	$I_{GES}$			400	nA
Turn-on delay time	$I_C=450A, V_{CE}=400 V$ $V_{GE}=\pm 15 V, R_G=5\Omega$ (inductive load)	$T_{vj}=25^{\circ}C$ $T_{vj}=150^{\circ}C$ $T_{vj}=175^{\circ}C$	$t_{d on}$		180 184 170		ns
Rise time	$I_C=450A, V_{CE}=400 V$ $V_{GE}=\pm 15 V, R_G=5\Omega$ (inductive load)	$T_{vj}=25^{\circ}C$ $T_{vj}=150^{\circ}C$ $T_{vj}=175^{\circ}C$	$t_r$		114 115 118		ns
Turn-off delay time	$I_C=450A, V_{CE}=400 V$ $V_{GE}=\pm 15 V, R_G=5\Omega$ (inductive load)	$T_{vj}=25^{\circ}C$ $T_{vj}=150^{\circ}C$ $T_{vj}=175^{\circ}C$	$t_{d off}$		382 418 426		ns
Fall time	$I_C=450A, V_{CE}=400 V$ $V_{GE}=\pm 15 V, R_G=5\Omega$ (inductive load)	$T_{vj}=25^{\circ}C$ $T_{vj}=150^{\circ}C$ $T_{vj}=175^{\circ}C$	$t_f$		215 321 358		ns
Turn-on energy loss per pulse	$I_C=450A, V_{CE}=400 V$ $V_{GE}=\pm 15 V, R_G=5\Omega$ $di/dt=3100A/us(T_{vj}=150^{\circ}C)$ (inductive load)	$T_{vj}=25^{\circ}C$ $T_{vj}=125^{\circ}C$ $T_{vj}=150^{\circ}C$	$E_{on}$		16.3 22.4 23.0		mJ
Turn-off energy loss per pulse	$I_C=450A, V_{CE}=400 V$ $V_{GE}=\pm 15 V, R_G=5\Omega$ $dv/dt=3000V/us(T_{vj}=150^{\circ}C)$ (inductive load)	$T_{vj}=25^{\circ}C$ $T_{vj}=125^{\circ}C$ $T_{vj}=150^{\circ}C$	$E_{off}$		26.5 34.5 35.8		mJ
Thermal resistance, junction to case	per IGBT		$R_{thJC}$		0.134		K/W

Temperature under switching conditions		$T_{vj\ op}$	-40		175	°C
--	--	--------------	-----	--	-----	----

## Diode, B

### Maximum Ratings

Parameter	Conditions	Symbol	Value	Unit
Repetitive peak reverse voltage	$T_{vj}=25^{\circ}\text{C}$	$V_{RRM}$	750	V
Implemented forward current		$I_{FN}$	820	A
Continuous DC forward current		$I_F$	450	A
Repetitive peak forward current	$t_p=1\text{ms}$	$I_{FRM}$	1640	A

### Characteristic Values

Parameter	Conditions	Symbol	Value			Unit
			Min.	Typ.	Max.	
Forward voltage	$I_F=820\text{A}, V_{GE}=0\text{V}$ $T_{vj}=25^{\circ}\text{C}$	$V_F$		1.85	2.20	V
	$I_F=820\text{A}, V_{GE}=0\text{V}$ $T_{vj}=150^{\circ}\text{C}$			1.98		
	$I_F=820\text{A}, V_{GE}=0\text{V}$ $T_{vj}=175^{\circ}\text{C}$			2.05		
Peak reverse recovery current	$I_F=450\text{A},$ $-diF/dt=3100\text{A}/\mu\text{s}$ $V_R=400\text{V}, V_{GE}=-15\text{V}$	$I_{RM}$		135		A
			$T_{vj}=150^{\circ}\text{C}$		190	
			$T_{vj}=175^{\circ}\text{C}$		300	
Reverse Recovery Time	$I_F=450\text{A},$ $-diF/dt=3100\text{A}/\mu\text{s}$ $V_R=400\text{V}, V_{GE}=-15\text{V}$	$T_{rr}$		115		ns
			$T_{vj}=150^{\circ}\text{C}$		230	
			$T_{vj}=175^{\circ}\text{C}$		292	
Recovered charge	$I_F=450\text{A},$ $-diF/dt=3100\text{A}/\mu\text{s}$ $V_R=400\text{V}, V_{GE}=-15\text{V}$	$Q_{rr}$		8.38		$\mu\text{C}$
			$T_{vj}=150^{\circ}\text{C}$		20.0	
			$T_{vj}=175^{\circ}\text{C}$		22.7	
Reverse recovered energy	$I_F=450\text{A},$ $-diF/dt=3100\text{A}/\mu\text{s}$ $V_R=400\text{V}, V_{GE}=-15\text{V}$	$E_{rec}$		2.38		mJ
			$T_{vj}=150^{\circ}\text{C}$		7.42	
			$T_{vj}=175^{\circ}\text{C}$		8.76	
Thermal resistance, junction to case	per diode	$R_{thJC}$		0.178		K/W
Temperature under switching conditions		$T_{vj\ op}$	-40		175	°C

## NTC-Thermistor

### Characteristic Values

Parameter	Conditions	Value			Unit
R25	T=25°C		5.00		KΩ
ΔR/R	Tc=100°C, R100=493.3Ω	-5		5	%
B-value	B (25/50), tolerance ±3%		3380		K
B-value	B (25/85), tolerance ±3%		3476		K
B-value	B (25/100), tolerance ±3%		3485		K

## Module

Parameter	Conditions	Symbol	Value			Unit
			Min.	Typ.	Max.	
Isolation test voltage	RMS, f=0Hz, t=1sec	V <sub>ISOL</sub>		4.2		kV
Internal isolation			Al <sub>2</sub> O <sub>3</sub>			
Storage temperature		T <sub>stg</sub>	-40		125	°C
Creepage distance	terminal to heatsink	dCreep	9.0			mm
	terminal to terminal		9.0			
Clearance	terminal to heatsink	dClear	4.5			mm
	terminal to terminal		4.5			
Comperative tracking index		CTI	> 200			

Parameter	Conditions	Symbol	Value			Unit
			Min.	Typ.	Max.	
Mounting torque for modul mounting	Screw M4 baseplate to heatsink Screw EJOT Delta PCB to frame	M	1.8		2.2	Nm
			0.45		0.55	
Weight		G		1270		g

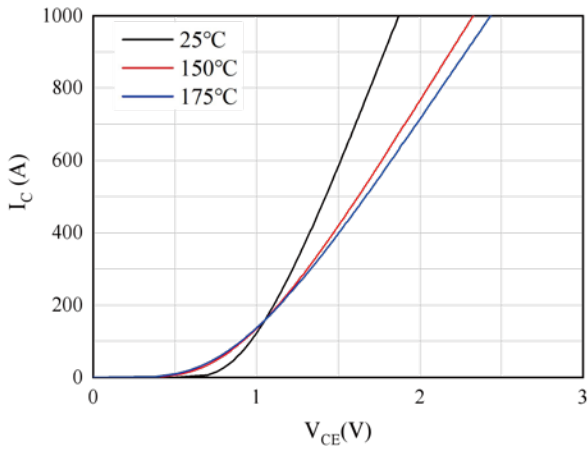

Fig 1. Typical output characteristics ( $V_{GE}=15V$ )

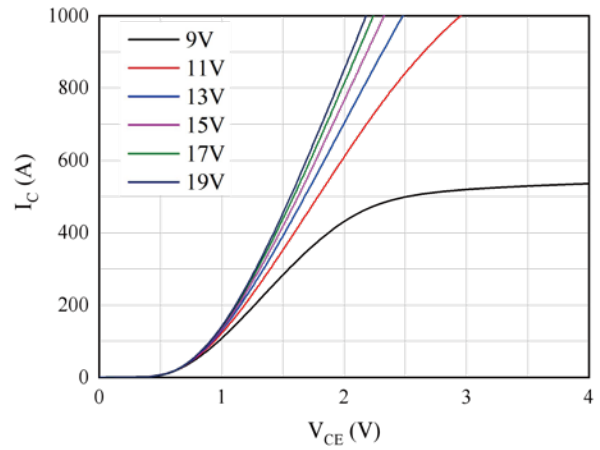

Fig 2. Typical output characteristics ( $T_{vj}=150^{\circ}C$ )

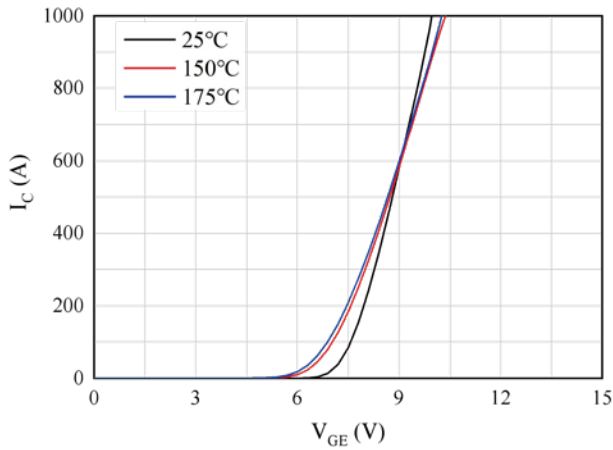

Fig 3. Typical transfer characteristic ( $V_{CE}=20V$ )

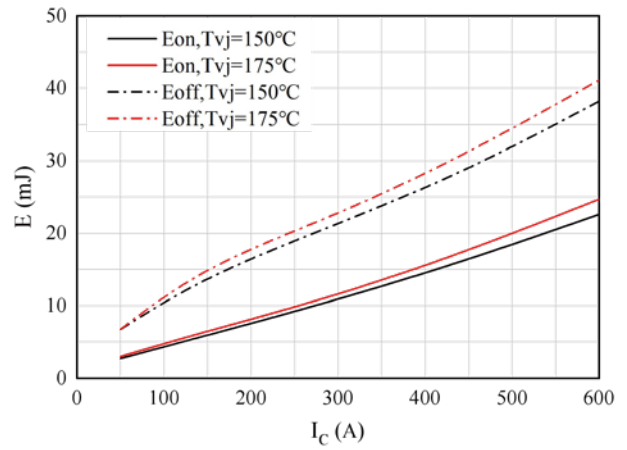

Fig 4. Switching losses of IGBT

$V_{GE}=\pm 15V, R_G=4\Omega, V_{CE}=400V$

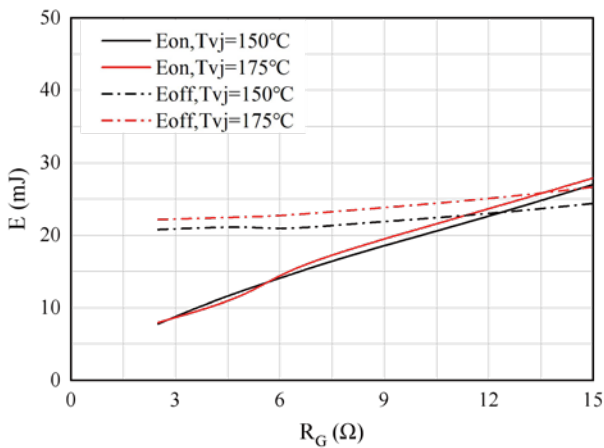

Fig 5. Switching losses of IGBT

$V_{GE}=\pm 15V, I_C=300A, V_{CE}=400V$

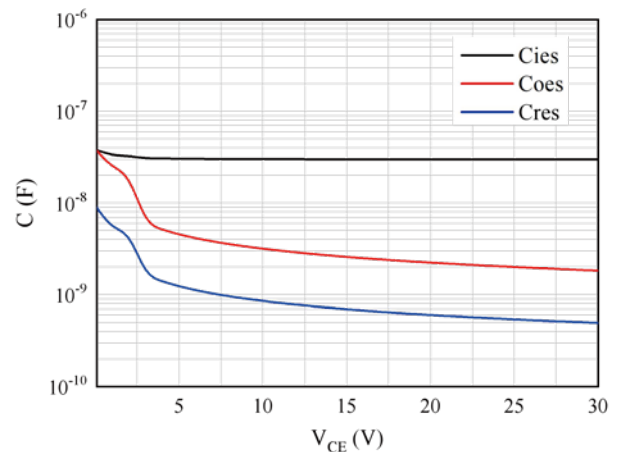

Fig 6. Capacitance characteristic

$f=100\text{ kHz}, V_{GE}=0\text{ V}, T_{vj}=25^{\circ}C$



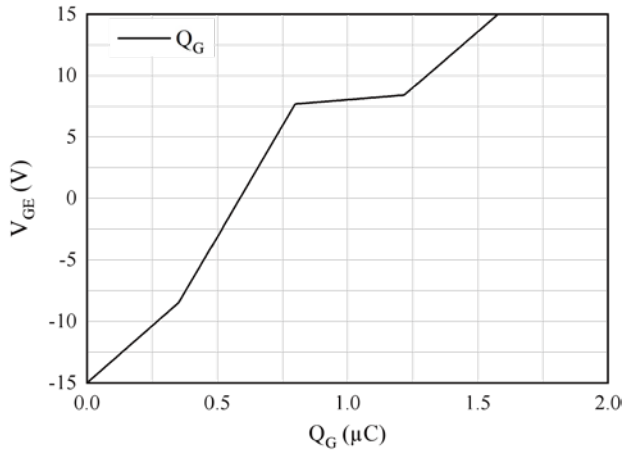

Fig 7. Gate charge characteristic of IGBT

$V_{CE} = 400\text{ V}, I = 300\text{ A}, T_{vj} = 25^\circ\text{C}$

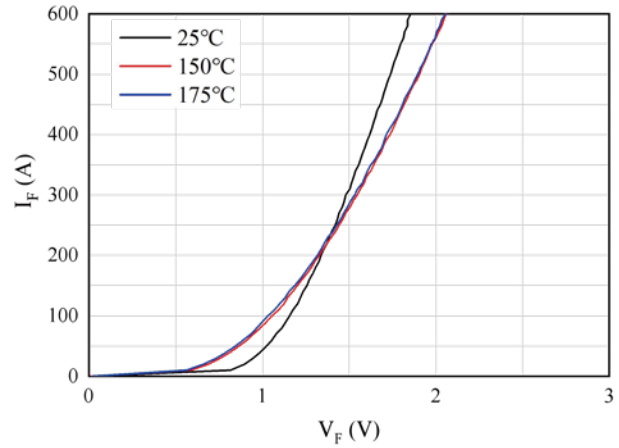

Fig 8. Forward characteristic of Diode

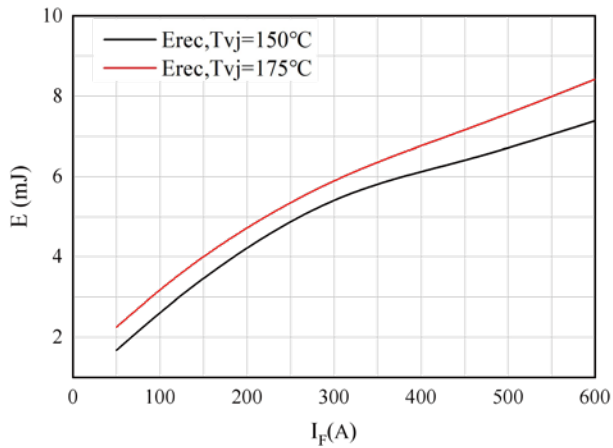

Fig9. Switching losses of Diode

$R_G = 4\Omega, V_{CE} = 400\text{ V}$

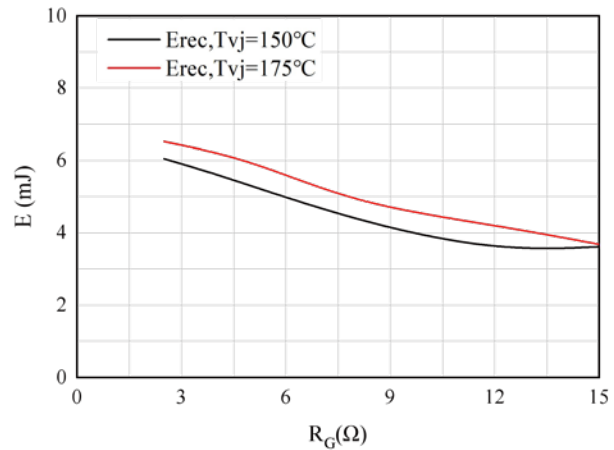

Fig 10. Switching losses of Diode

$I_C = 300\text{ A}, V_{CE} = 400\text{ V}$

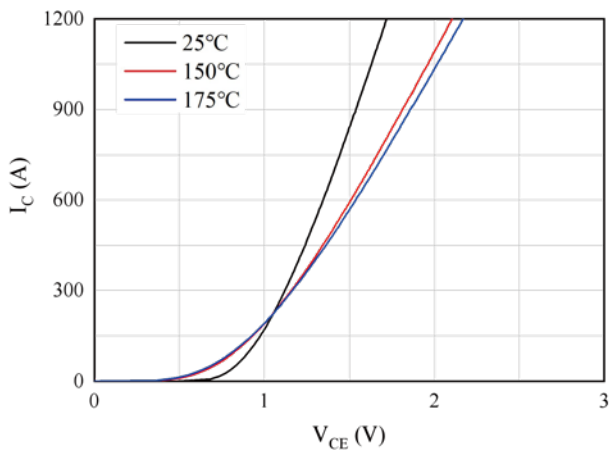

Fig 11. Typical output characteristics ( $V_{GE} = 15\text{ V}$ )

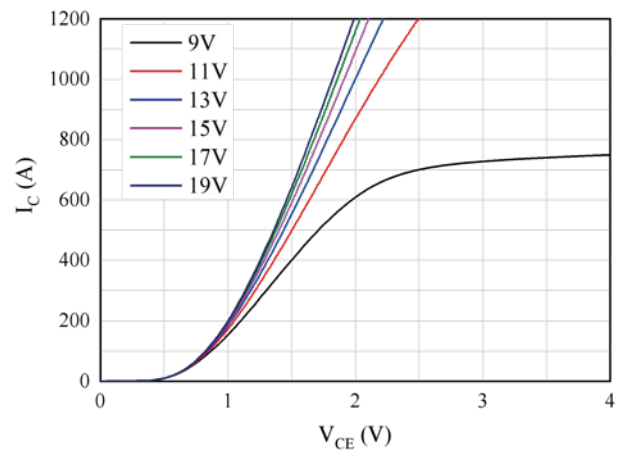

Fig 12. Typical output characteristics ( $T_{vj} = 150^\circ\text{C}$ )

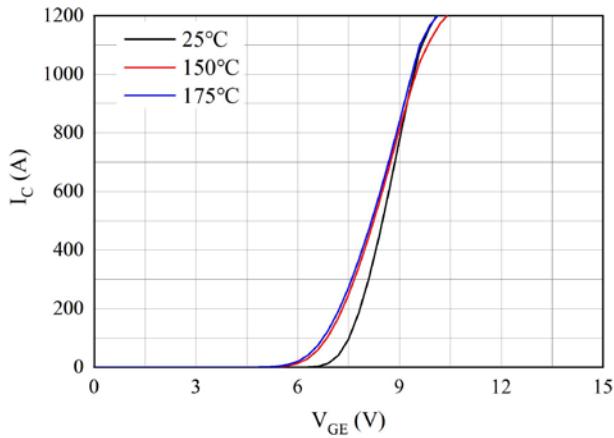

Fig 13. Typical transfer characteristic( $V_{CE}=20V$ )

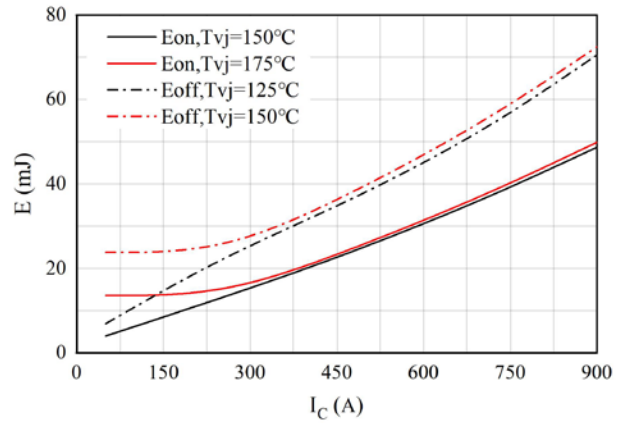

Fig 14. Switching losses of IGBT

$V_{GE} = \pm 15V, R = 5 \Omega, V_{CE}=400V$

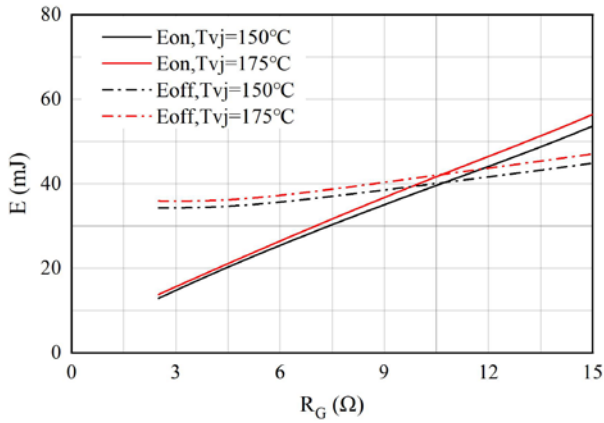

Fig 15. Switching losses of IGBT

$V_{GE} = \pm 15V, I_C=450A, V_{CE}=400V$

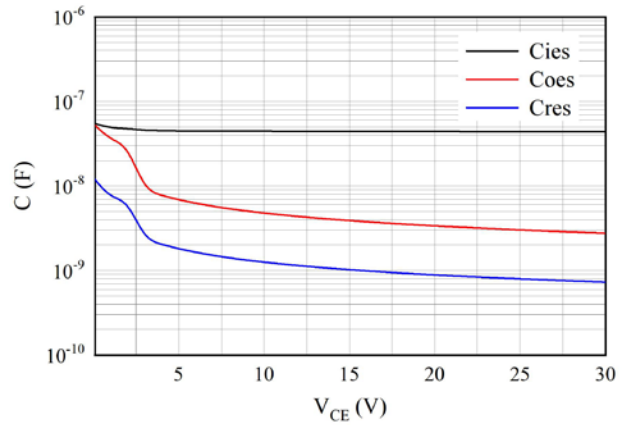

Fig 16. Capacitance characteristic

$f=100 \text{ kHz}, V_G = 0V, T_{vj}=25^\circ C$

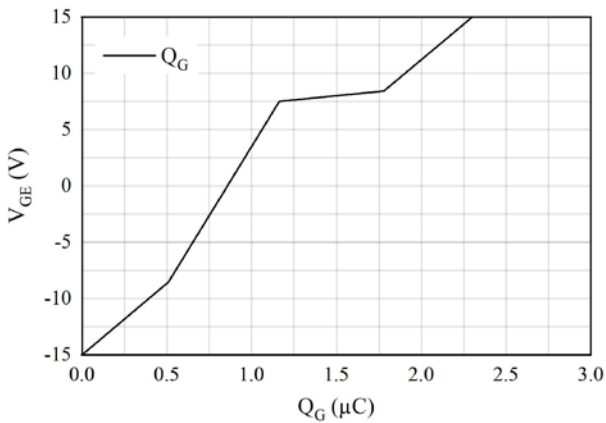

Fig 17. Gate charge characteristic of IGBT

$V_{CE}=400V, I_C=300A, T_{vj}=25^\circ C$

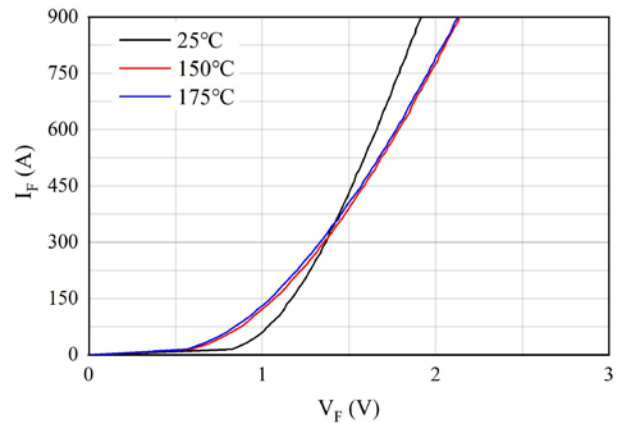

Fig 18. Forward characteristic of Diode

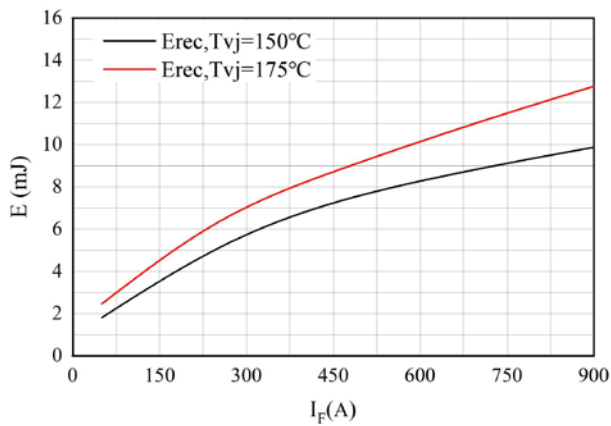

Fig 19. Switching losses of Diode  
 $R_G = 5\Omega, V_{CE} = 400V$

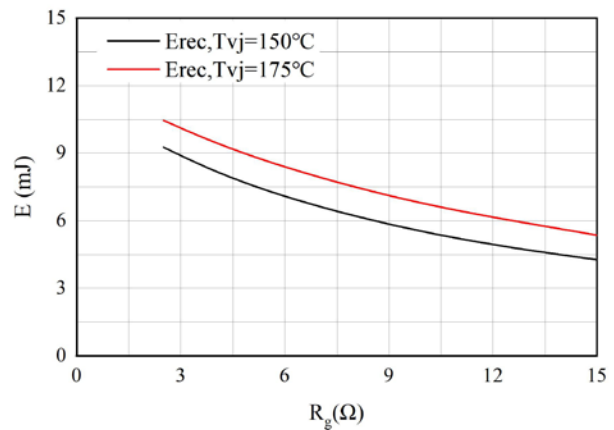

Fig 20. Switching losses of Diode  
 $I_C = 450A, V_{CE} = 400V$

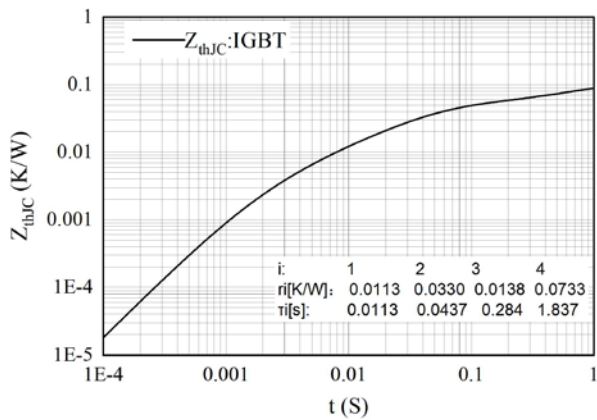

Fig 21. Transient thermal impedance IGBT, Inverter

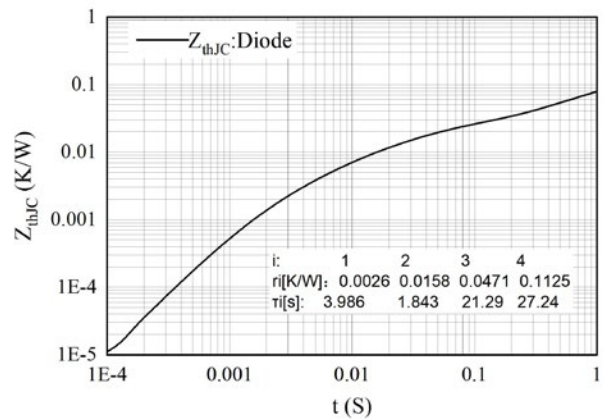

Fig 22. Transient thermal impedance Diode

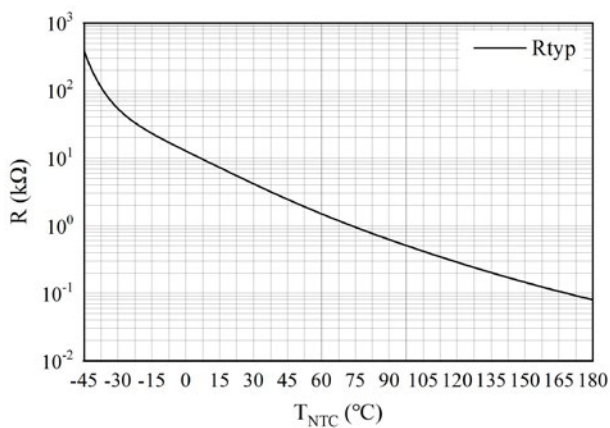
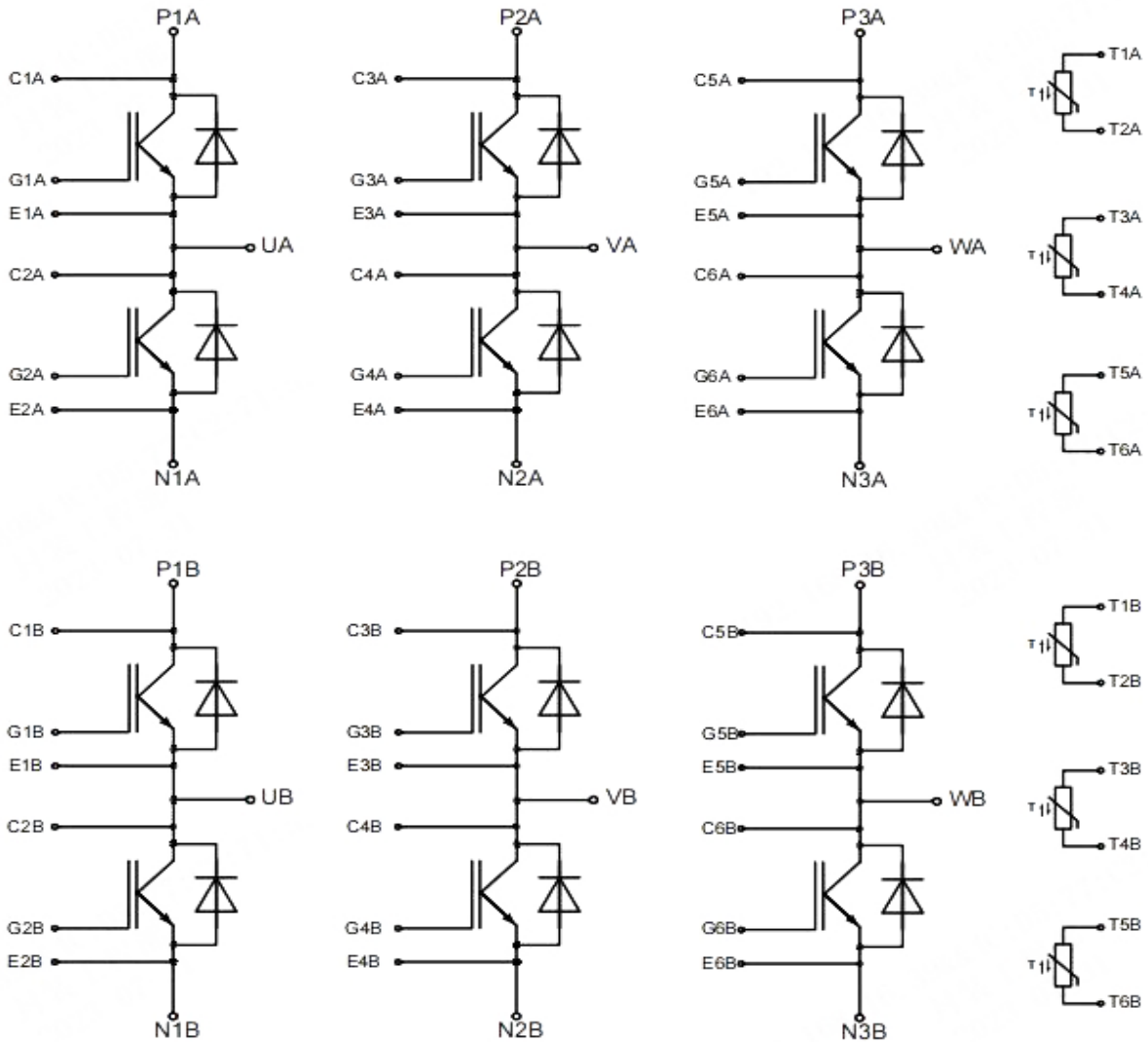

Fig 23. NTC-Themistor-temperature characteristic

**Circuit diagram**



**Package outlines**

