

34mm Half Bridge IGBT Module

$V_{CES}=1200V$, $I_{C\ nom}=75A$ / $I_{CRM}=150A$

Electrical characteristics :

- 1200V Trench / Field Stop process
- Low switching losses
- V_{cesat} has a positive temperature coefficient

Applications:

- Inverter welding machine

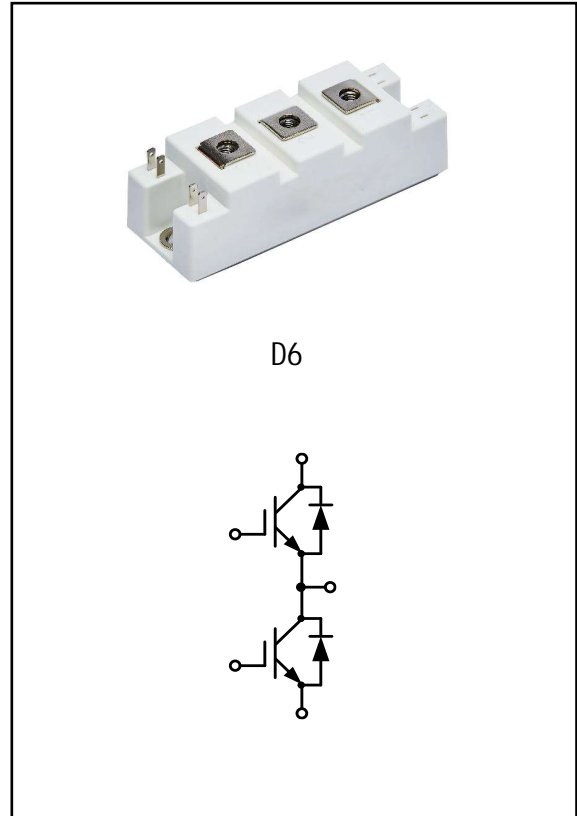

IGBT, Inverter

Maximum Ratings

Parameter	Conditions	Symbol	Value	Unit
Collector-Emitter voltage	$T_{vj}=25^{\circ}C$	V_{CES}	1200	V
Continuous DC collector current	$T_C=100^{\circ}C$, $T_{vj\ max}=175^{\circ}C$	$I_{C\ nom}$	75	A
Repetitive peak collector current	$t_p=1\ ms$	I_{CRM}	150	A
Gate emitter voltage		V_{GE}	± 20	V

Characteristic Values

Parameter	Conditions	Symbol	Value			Unit
			Min.	Typ.	Max.	
Collector-Emitter saturation voltage	$V_{GE}=15V, I_C=75A$ $T_{vj}=25^{\circ}C$	V_{CEsat}		1.98	2.50	V
	$V_{GE}=15V, I_C=75A$ $T_{vj}=125^{\circ}C$			2.45		
	$V_{GE}=15V, I_C=75A$ $T_{vj}=150^{\circ}C$			2.56		
Gate-Emitter threshold voltage	$I_C = 2.6mA, V_{GE} = V_{CE}$ $T_{vj}=25^{\circ}C$	$V_{GE(th)}$	5.00	5.70	6.30	
Gate charge	$V_{GE}=-15V...+15V$	Q_G		0.63		μC
Internal gate resistor	$T_{vj}=25^{\circ}C$	R_{Gint}		None		Ω
Input capacitance	$f=100KHz, V_{CE}=25V, V_{GE}=0V$ $T_{vj}=25^{\circ}C$	C_{ies}		8.28		nF
Reverse transfer capacitance		C_{res}		0.13		
Collector-emitter cut-off current	$V_{CE}=1200V, V_{GE}=0V$ $T_{vj}=25^{\circ}C$	I_{CES}			1	mA
Gate-emitter leakage current	$V_{CE}=0V, V_{GE}=20V$ $T_{vj}=25^{\circ}C$	I_{GES}			100	nA
Turn-on delay time	$I_C=30A, V_{CE}=600V$ $V_{GE}=\pm 15V, R_G=15\Omega$ (inductive load) $T_{vj}=25^{\circ}C$	$t_{d on}$		59		ns
	$T_{vj}=125^{\circ}C$			53		
	$T_{vj}=150^{\circ}C$			50		
Rise time	$I_C=30A, V_{CE}=600V$ $V_{GE}=\pm 15V, R_G=15\Omega$ (inductive load) $T_{vj}=25^{\circ}C$	t_r		26		ns
	$T_{vj}=125^{\circ}C$			24		
	$T_{vj}=150^{\circ}C$			26		
Turn-off delay time	$I_C=30A, V_{CE}=600V$ $V_{GE}=\pm 15V, R_G=15\Omega$ (inductive load) $T_{vj}=25^{\circ}C$	$t_{d off}$		270		ns
	$T_{vj}=125^{\circ}C$			292		
	$T_{vj}=150^{\circ}C$			302		
Fall time	$I_C=30A, V_{CE}=600V$ $V_{GE}=\pm 15V, R_G=15\Omega$ (inductive load) $T_{vj}=25^{\circ}C$	t_f		85		ns
	$T_{vj}=125^{\circ}C$			144		
	$T_{vj}=150^{\circ}C$			170		
Turn-on energy loss per pulse	$I_C=30A, V_{CE}=600V$ $V_{GE}=\pm 15V, R_G=15\Omega$ $di/dt = 900A/\mu s$ ($T_{vj} = 150^{\circ}C$) (inductive load) $T_{vj}=25^{\circ}C$	E_{on}		1.42		mJ
	$T_{vj}=125^{\circ}C$			2.15		
	$T_{vj}=150^{\circ}C$			2.32		
Turn-off energy loss per pulse	$I_C=30A, V_{CE}=600V$ $V_{GE}=\pm 15V, R_G=15\Omega$ $dv/dt = 6500V/\mu s$ ($T_{vj} = 150^{\circ}C$) (inductive load) $T_{vj}=25^{\circ}C$	E_{off}		1.22		mJ
	$T_{vj}=125^{\circ}C$			1.66		
	$T_{vj}=150^{\circ}C$			1.74		
Temperature under switching conditions		$T_{vj op}$	-40		150	$^{\circ}C$

Diode, Inverter

Maximum Ratings

Parameter	Conditions	Symbol	Value	Unit
Repetitive peak reverse voltage	$T_{vj}=25^{\circ}\text{C}$	V_{RRM}	1200	V
Continuous DC forward current		I_F	30	A
Repetitive peak forward current	$t_p=1\text{ms}$	I_{FRM}	60	A
I^2t -value	$t_p=10\text{ms}$, $\sin 180^{\circ}$, $T_j=125^{\circ}\text{C}$	I^2t	490	A^2s

Characteristic Values

Parameter	Conditions	Symbol	Value			Unit
			Min.	Typ.	Max.	
Forward voltage	$I_F=30\text{A}$, $V_{GE}=0\text{V}$	$T_{vj}=25^{\circ}\text{C}$		1.86	2.60	V
	$I_F=30\text{A}$, $V_{GE}=0\text{V}$	$T_{vj}=125^{\circ}\text{C}$		1.60		
	$I_F=30\text{A}$, $V_{GE}=0\text{V}$	$T_{vj}=150^{\circ}\text{C}$		1.50		
Peak reverse recovery current	$I_F=30\text{A}$,	$T_{vj}=25^{\circ}\text{C}$		47		A
	$-di_F/dt=900\text{A}/\mu\text{s}$ ($T_{vj}=150^{\circ}\text{C}$)	$T_{vj}=125^{\circ}\text{C}$		76		
	$V_R=600\text{V}$, $V_{GE}=-15\text{V}$	$T_{vj}=150^{\circ}\text{C}$		86		
Recovered charge	$I_F=30\text{A}$,	$T_{vj}=25^{\circ}\text{C}$		1.28		μC
	$-di_F/dt=900\text{A}/\mu\text{s}$ ($T_{vj}=150^{\circ}\text{C}$)	$T_{vj}=125^{\circ}\text{C}$		4.94		
	$V_R=600\text{V}$, $V_{GE}=-15\text{V}$	$T_{vj}=150^{\circ}\text{C}$		7.08		
Reverse recovered energy	$I_F=30\text{A}$,	$T_{vj}=25^{\circ}\text{C}$		0.24		mJ
	$-di_F/dt=900\text{A}/\mu\text{s}$ ($T_{vj}=150^{\circ}\text{C}$)	$T_{vj}=125^{\circ}\text{C}$		1.75		
	$V_R=600\text{V}$, $V_{GE}=-15\text{V}$	$T_{vj}=150^{\circ}\text{C}$		2.79		
Temperature under switching conditions		$T_{vj\text{ op}}$	-40		150	$^{\circ}\text{C}$

Module

Parameter	Conditions	Symbol	Value			Unit
Isolation test voltage	RMS, $f=50\text{Hz}$, $t=1\text{min}$	V_{ISOL}	2500			V
Internal isolation			Al_2O_3			
Storage temperature		T_{stg}	-40		125	$^{\circ}\text{C}$
Mounting torque for modul mounting		M	3.0		5.0	Nm
Terminal Connection Torque		M	2.5		5.0	Nm
Weight		W		150		g

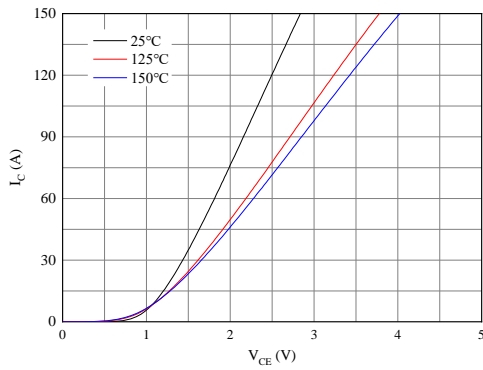

Fig 1. Typical output characteristics ($V_{GE}=15V$)

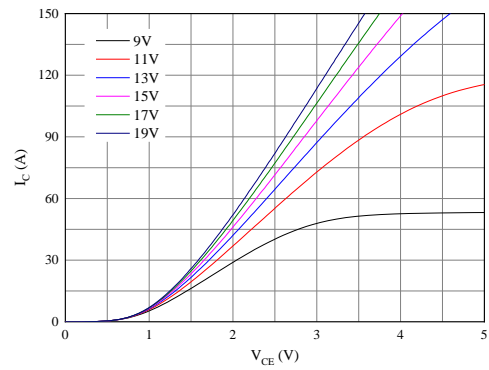

Fig 2. Typical output characteristics ($T_{vj}=150^{\circ}C$)

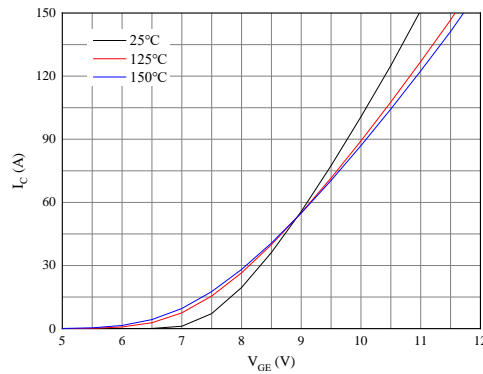

Fig 3. Typical transfer characteristic ($V_{CE}=20V$)

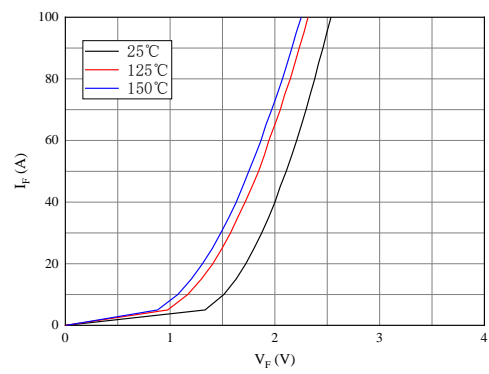

Fig 4. Forward characteristic of Diode

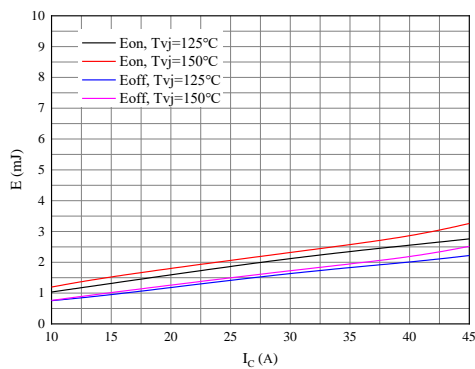

Fig 5. Switching losses of IGBT

$V_{GE}=\pm 15V$, $R_{Gon}=15\Omega$, $R_{Goff}=15\Omega$, $V_{CE}=600V$

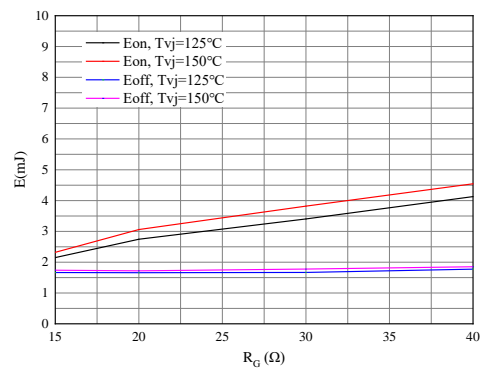

Fig 6. Switching losses of IGBT

$V_{GE}=\pm 15V$, $I_C=30A$, $V_{CE}=600V$

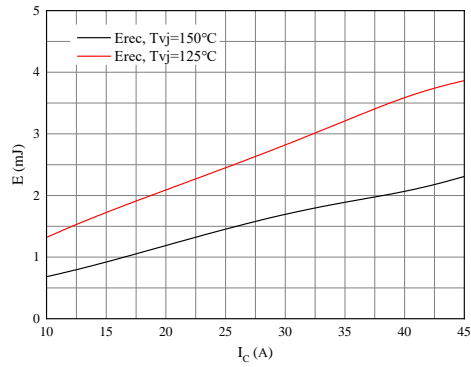

Fig 7. Switching losses of Diode

$R_{Gon}=15\Omega, V_{CE}=600V$

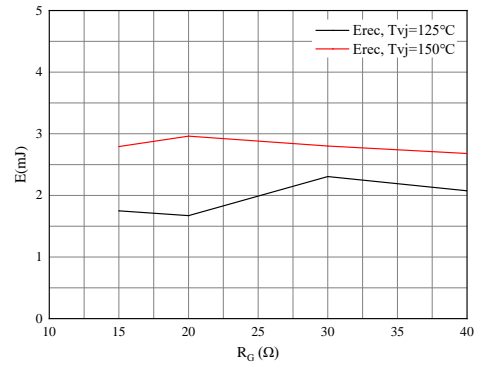

Fig 8. Switching losses of Diode

$I_F=30A, V_{CE}=600V$

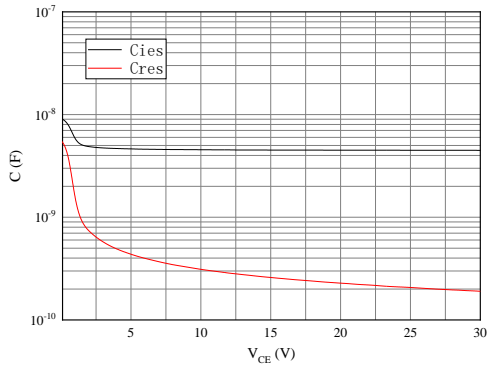
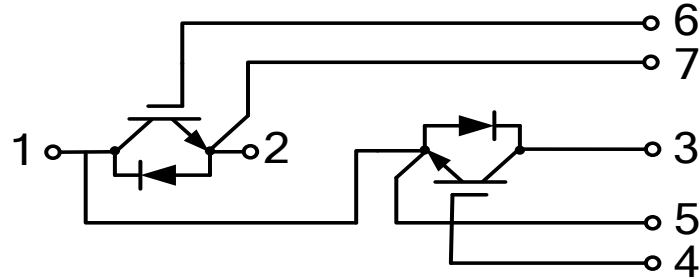

Fig 9. Capacitance characteristic

Circuit diagram



Package outlines

