

SixPack IGBT Module

$V_{CES}=1200V$, $I_{C\ nom}=150A$ / $I_{CRM}=300A$

Electrical characteristics :

- 1200V Trench /Field Stop process
- Low switching losses
- V_{cesat} has a positive temperature coefficient

Applications:

- Power Converters
- Servo Drives
- Inverter

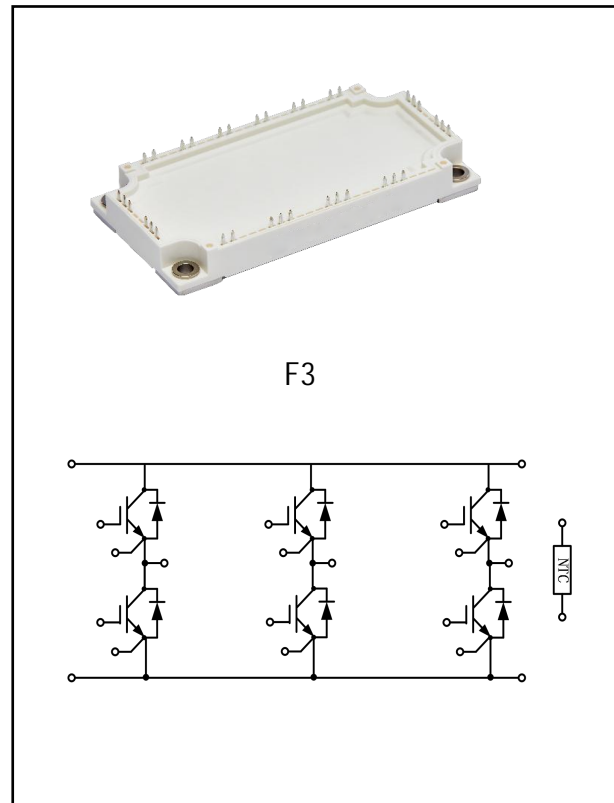

IGBT, Inverter

Maximum Ratings

Parameter	Conditions	Symbol	Value	Unit
Collector-Emitter voltage	$T_{vj}=25^{\circ}C$	V_{CES}	1200	V
Continuous DC collector current	$T_C=100^{\circ}C$, $T_{vj\ max}=175^{\circ}C$	$I_{C\ nom}$	150	A
Repetitive peak collector current	$t_p=1\ ms$	I_{CRM}	300	A
Gate emitter voltage		V_{GE}	+/-20	V

Characteristic Values

Parameter	Conditions	Symbol	Value			Unit			
			Min.	Typ.	Max.				
Collector-Emitter saturation voltage	$V_{GE}=15V, I_C=150A$ $V_{GE}=15V, I_C=150A$ $V_{GE}=15V, I_C=150A$	$T_{vj}=25^{\circ}C$ $T_{vj}=125^{\circ}C$ $T_{vj}=150^{\circ}C$	V_{CEsat}	1.53 1.75 1.81	2.10	V			
Gate-Emitter threshold voltage	$I_C=5.3mA, V_{GE}=V_{CE}$	$T_{vj}=25^{\circ}C$	$V_{GE(th)}$	5.20 5.80	6.40				
Gate charge	$V_{GE}=-15V...+15V$		Q_G	1.56		μC			
Internal gate resistor	$T_{vj}=25^{\circ}C$		R_{Gint}	1.10		Ω			
Input capacitance	$f=100KHz$ $V_{CE}=25V, V_{GE}=0V$	$T_{vj}=25^{\circ}C$	C_{ies}	23.82		nF			
Reverse transfer capacitance			C_{res}	0.22					
Collector-emitter cut-off current	$V_{CE}=1200V, V_{GE}=0V$	$T_{vj}=25^{\circ}C$	I_{CES}		1	mA			
Gate-emitter leakage current	$V_{CE}=0V, V_{GE}=20V$	$T_{vj}=25^{\circ}C$	I_{GES}		100	nA			
Turn-on delay time	$I_C=150A, V_{CE}=600V$ $V_{GE}=\pm 15V, R_G=5\Omega$ (电感负载)/(inductive load)	$T_{vj}=25^{\circ}C$ $T_{vj}=125^{\circ}C$ $T_{vj}=150^{\circ}C$	t_{don}	102 103 104		ns			
Rise time				$I_C=150A, V_{CE}=600V$ $V_{GE}=\pm 15V, R_G=5\Omega$ (电感负载)/(inductive load)	$T_{vj}=25^{\circ}C$ $T_{vj}=125^{\circ}C$ $T_{vj}=150^{\circ}C$		t_r	47 55 56	
Turn-off delay time								$I_C=150A, V_{CE}=600V$ $V_{GE}=\pm 15V, R_G=5\Omega$ (电感负载)/(inductive load)	$T_{vj}=25^{\circ}C$ $T_{vj}=125^{\circ}C$ $T_{vj}=150^{\circ}C$
Fall time	$I_C=150A, V_{CE}=600V$ $V_{GE}=\pm 15V, R_G=5\Omega$ (电感负载)/(inductive load)	$T_{vj}=25^{\circ}C$ $T_{vj}=125^{\circ}C$ $T_{vj}=150^{\circ}C$	t_f			180 257 275			
Turn-on energy loss per pulse				$I_C=150A, V_{CE}=600V$ $V_{GE}=\pm 15V, R_G=5\Omega$ $di/dt=2150A/\mu s(T_{vj}=150^{\circ}C)$ (电感负载)/(inductive load)	$T_{vj}=25^{\circ}C$ $T_{vj}=125^{\circ}C$ $T_{vj}=150^{\circ}C$	E_{on}	11.09 19.92 22.71		
Turn-off energy loss per pulse							$I_C=150A, V_{CE}=600V$ $V_{GE}=\pm 15V, R_G=5\Omega$ $du/dt=4250V/\mu s(T_{vj}=150^{\circ}C)$ (inductive load)	$T_{vj}=25^{\circ}C$ $T_{vj}=125^{\circ}C$ $T_{vj}=150^{\circ}C$	E_{off}
SC data	$V_{GE}\leq 15V, V_{cc}=800V$ $V_{CEmax}=V_{CES}-L_{sCE} \cdot di/dt, t_p\leq 10\mu s,$ $T_{vj}=150^{\circ}C$	I_{SC}	730						
Temperature under switching conditions		$T_{vj op}$	-40	150	$^{\circ}C$				

Diode, Inverter

Maximum Ratings

Parameter	Conditions	Symbol	Value	Unit
Repetitive peak reverse voltage	$T_{vj}=25^{\circ}\text{C}$	V_{RRM}	1200	V
Continuous DC forward current		I_F	150	A
Repetitive peak forward current	$t_p=1\text{ms}$	I_{FRM}	300	A
I^2t -value	$t_p=10\text{ms}$, $\sin 180^{\circ}$, $T_{vj}=125^{\circ}\text{C}$	I^2t	8000	A^2s

Characteristic Values

Parameter	Conditions	Symbol	Value			Unit
			Min.	Typ.	Max.	
Forward voltage	$I_F=150\text{A}$, $V_{GE}=0\text{V}$ $T_{vj}=25^{\circ}\text{C}$	V_F		2.05	2.40	V
	$I_F=150\text{A}$, $V_{GE}=0\text{V}$ $T_{vj}=125^{\circ}\text{C}$		1.75			
	$I_F=150\text{A}$, $V_{GE}=0\text{V}$ $T_{vj}=150^{\circ}\text{C}$		1.67			
Peak reverse recovery current	$I_F=150\text{A}$, $-di_F/dt=2150\text{A}/\mu\text{s}(T_{vj}=150^{\circ}\text{C})$ $V_R=600\text{V}$, $V_{GE}=-15\text{V}$ $T_{vj}=25^{\circ}\text{C}$	I_{RM}		138	A	
	$T_{vj}=125^{\circ}\text{C}$		189			
	$T_{vj}=150^{\circ}\text{C}$		198			
Recovered charge	$I_F=150\text{A}$, $-di_F/dt=2150\text{A}/\mu\text{s}(T_{vj}=150^{\circ}\text{C})$ $V_R=600\text{V}$, $V_{GE}=-15\text{V}$ $T_{vj}=25^{\circ}\text{C}$	Q_F		11.67	μC	
	$T_{vj}=125^{\circ}\text{C}$		29.77			
	$T_{vj}=150^{\circ}\text{C}$		35.09			
Reverse recovered energy	$I_F=150\text{A}$, $-di_F/dt=2150\text{A}/\mu\text{s}(T_{vj}=150^{\circ}\text{C})$ $V_R=600\text{V}$, $V_{GE}=-15\text{V}$ $T_{vj}=25^{\circ}\text{C}$	E_{rec}		3.37	mJ	
	$T_{vj}=125^{\circ}\text{C}$		9.26			
	$T_{vj}=150^{\circ}\text{C}$		11.07			
Temperature under switching conditions		$T_{vj\text{op}}$	-40		150	$^{\circ}\text{C}$

NTC-Thermistor

Characteristic Values

Parameter	Conditions	Symbol	Value			Unit
			Min.	Typ.	Max.	
Rated resistances	$T_c=25^{\circ}\text{C}$, $\pm 5\%$	R_{25}		5.0		$\text{k}\Omega$
B-value	$\pm 1\%$	$B_{25/50}$		3380		K

Module

Parameter	Conditions	Symbol	Value			Unit
Isolation test voltag	RMS, $f=50\text{Hz}$, $t=1\text{min}$	V_{ISOL}	2500			V
Internal isolation			Al_2O_3			
Storage temperature		T_{stg}	-40		125	$^{\circ}\text{C}$
Mounting torque for modul mounting		M	3.0		6.0	Nm
Weight		W		301		g

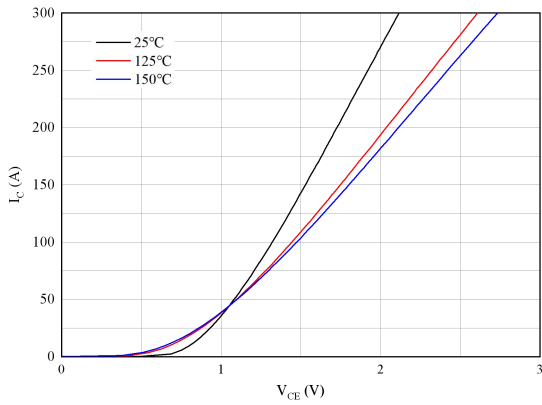

Fig 1. Output characteristics IGBT, Inverter

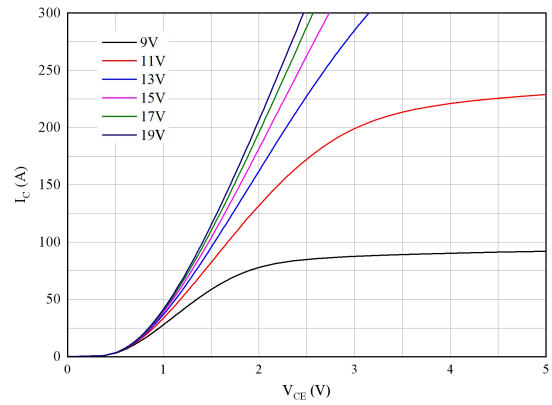

Fig 2. Output characteristics IGBT, Inverter

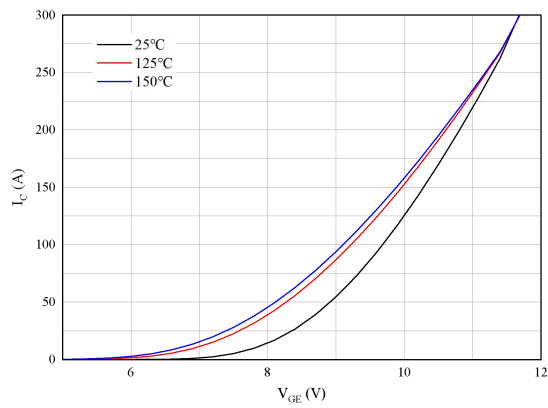

Fig 3. Transfer characteristics IGBT, Inverter

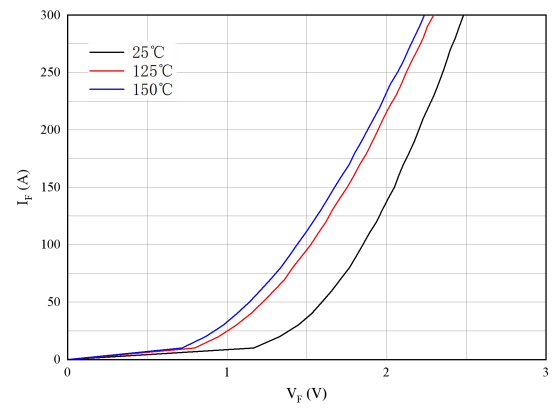

Fig 4. Forward characteristic of Diode

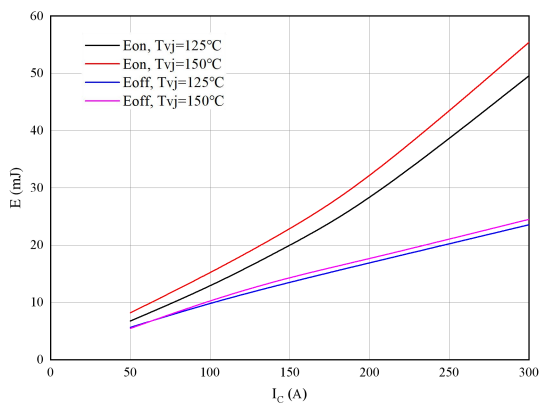

Fig 5. Switching losses of IGBT

$V_{GE} = \pm 15V, R_{Gon} = 5\Omega, R_{Goff} = 5\Omega, V_{CE} = 600V$

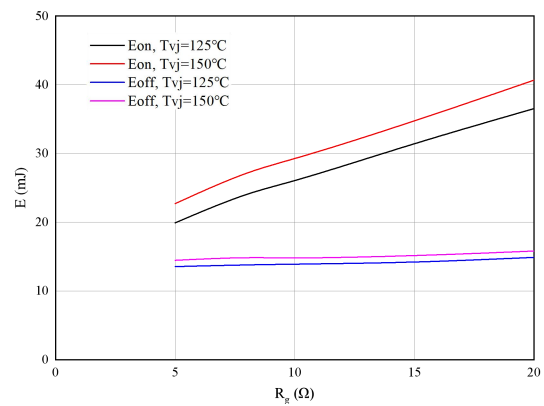

Fig 6. Switching losses of IGBT

$V_{GE} = \pm 15V, I_C = 150A, V_{CE} = 600V$

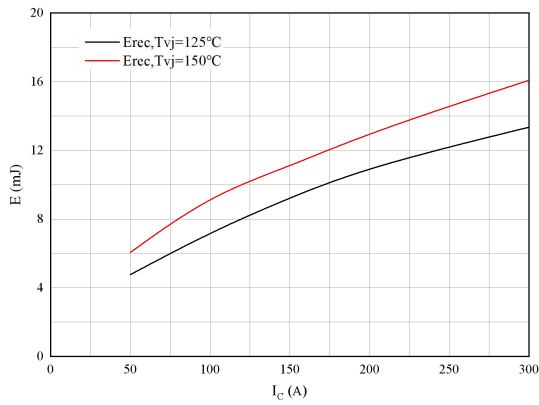

Fig 7. Switching losses of Diode

$R_{Gon}=5\ \Omega, R_{Goff}=5\ \Omega, V_{CE}=600V$

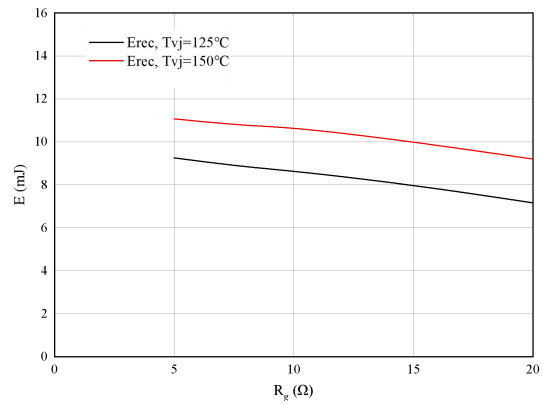

Fig 8. Switching losses of Diode

$I_F=150A, V_{CE}=600V$

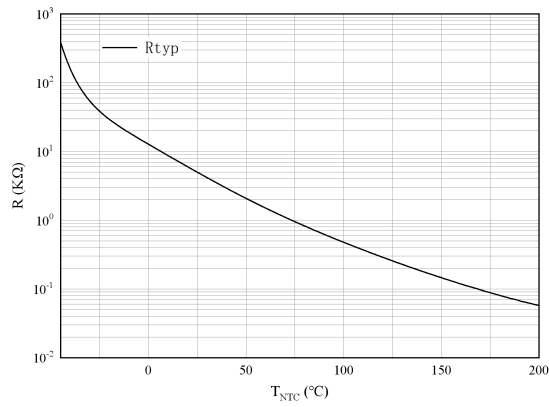

Fig 9. NTC-Themistor-temperature characteristic

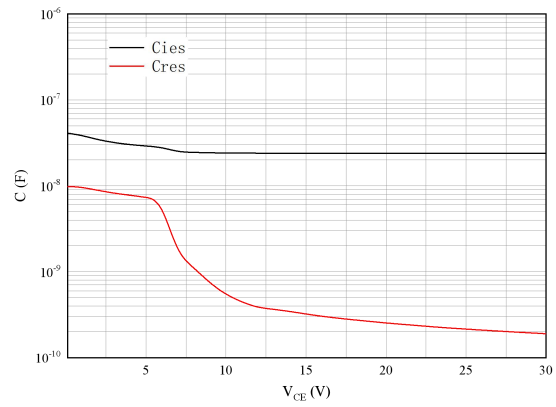
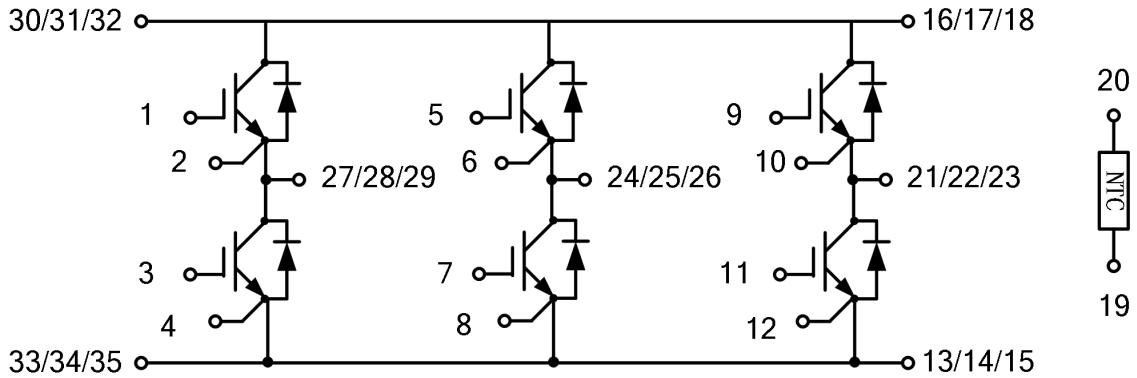

Fig 10. Capacitance characteristic

Circuit diagram



Package outlines

