

Half Bridge IGBT Module

$V_{CES} = 1200V$, $I_{C\ nom} = 900A$ / $I_{CRM} = 1800A$

Electrical characteristics :

- 1200V Trench / Field Stop technology
- Low switching losses
- V_{cesat} with positive temperature coefficient

Applications:

- UPS system
- Servo drives
- High Power Converters
- Motor drives

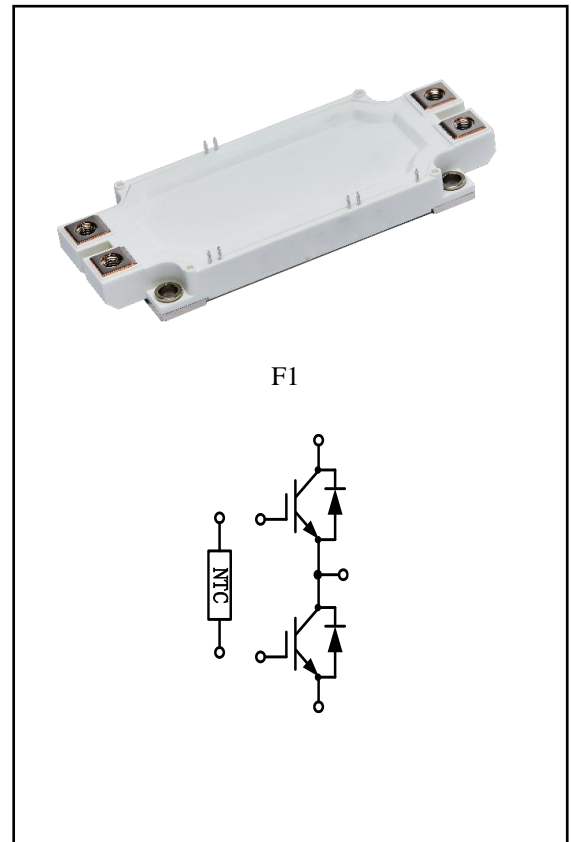

IGBT, Inverter

Maximum Ratings

Parameter	Conditions	Symbol	Value	Unit
Collector-Emitter voltage	$T_{vj} = 25^{\circ}C$	V_{CES}	1200	V
Continuous DC collector current	$T_C = 90^{\circ}C$, $T_{vj\ max} = 175^{\circ}C$	$I_{C\ nom}$	900	A
Repetitive peak collector current	$t_p = 1ms$	I_{CRM}	1800	A
Total power dissipation	$T_C = 25^{\circ}C$, $T_{vj\ max} = 175^{\circ}C$	P_{tot}	3600	W
Gate emitter voltage		V_{GE}	± 20	V

Characteristic Values

Parameter	Conditions	Symbol	Value			Unit
			Min.	Typ.	Max.	
Collector-Emitter saturation voltage	$V_{GE}=15V, I_C=900A$ $T_{vj}=25^{\circ}C$ $V_{GE}=15V, I_C=900A$ $T_{vj}=125^{\circ}C$ $V_{GE}=15V, I_C=900A$ $T_{vj}=175^{\circ}C$	$V_{CE\ sat}$		1.65 1.95 2.10	2.10	V
Gate-Emitter threshold voltage	$I_C=18mA, V_{GE}=V_{CE},$ $T_{vj}=25^{\circ}C$	V_{GEth}	5.2	5.8	6.4	
Gate charge	$V_{GE}=-15V...+15V$	Q_G		11.5		μC
Internal gate resistor	$T_{vj}=25^{\circ}C$	R_{Gint}		0.5		Ω
Input capacitance	$f=100KHz, V_{CE}=25V, V_{GE}=0V$ $T_{vj}=25^{\circ}C$	C_{ies}		140		nF
Reverse transfer capacitance		C_{res}		0.55		
Collector-emitter cut-off current	$V_{CE}=1200V, V_{GE}=0V$ $T_{vj}=25^{\circ}C$	I_{CES}			0.1	mA
Gate-emitter leakage current	$V_{CE}=0V, V_{GE}=20V$ $T_{vj}=25^{\circ}C$	I_{GES}			100	nA
Turn-on delay time	$I_C=900A, V_{CE}=600V$ $T_{vj}=25^{\circ}C$ $V_{GE}=\pm 15V, R_G=0.5\Omega$ $T_{vj}=125^{\circ}C$ (inductive load) $T_{vj}=175^{\circ}C$	$t_{d\ on}$		409 435 445		ns
Rise time	$I_C=900A, V_{CE}=600V$ $T_{vj}=25^{\circ}C$ $V_{GE}=\pm 15V, R_G=0.5\Omega$ $T_{vj}=125^{\circ}C$ (inductive load) $T_{vj}=175^{\circ}C$	t_r		75 86 95		
Turn-off delay time	$I_C=900A, V_{CE}=600V$ $T_{vj}=25^{\circ}C$ $V_{GE}=\pm 15V, R_G=0.5\Omega$ $T_{vj}=125^{\circ}C$ (inductive load) $T_{vj}=175^{\circ}C$	$t_{d\ off}$		510 575 620		
Fall time	$I_C=900A, V_{CE}=600V$ $T_{vj}=25^{\circ}C$ $V_{GE}=\pm 15V, R_G=0.5\Omega$ $T_{vj}=125^{\circ}C$ (inductive load) $T_{vj}=175^{\circ}C$	t_f		147 238 295		
Turn-on energy loss per pulse	$I_C=900A, V_{CE}=600V$ $T_{vj}=25^{\circ}C$ $di/dt=7500A/us(T_{vj}=175^{\circ}C)$ $T_{vj}=125^{\circ}C$ $V_{GE}=\pm 15V, R_G=0.5\Omega$ $T_{vj}=175^{\circ}C$	E_{on}		36 69 93		mJ
Turn-off energy loss per pulse	$I_C=900A, V_{CE}=600V$ $T_{vj}=25^{\circ}C$ $dv/dt=3100V/us(T_{vj}=175^{\circ}C)$ $T_{vj}=125^{\circ}C$ $V_{GE}=\pm 15V, R_G=0.5\Omega$ $T_{vj}=175^{\circ}C$	E_{off}		94 122 139		mJ
SC data	$V_{GE}\leq 15V, V_{CC}=800V$ $t_p\leq 8us, T_{vj}=150^{\circ}C$ $V_{CEmax}=V_{CES}-L_{sCE}\cdot di/dt$ $t_p\leq 6us, T_{vj}=175^{\circ}C$	I_{sc}		3400 3200		A
Thermal resistance, junction to case	per IGBT	R_{thJC}			0.040	K/W
Temperature under switching conditions	$T_{vj\ op} > 150^{\circ}C$ is only allowed for operation at overload conditions.	$T_{vj\ op}$	-40		175	$^{\circ}C$

Diode, Inverter

Maximum Ratings

Parameter	Conditions	Symbol	Value	Unit
Repetitive peak reverse voltage	$T_{vj}=25^{\circ}\text{C}$	V_{RRM}	1200	V
Continuous DC forward current		I_F	900	A
Repetitive peak forward current	$t_p=1\text{ms}$	I_{FRM}	1800	A
I^2t -value	$t_p=10\text{ms}$, $\sin 180^{\circ}$, $T_j=125^{\circ}\text{C}$	I^2t	30000	A^2s

Characteristic Values

Parameter	Conditions	Symbol	Value			Unit
			Min.	Typ.	Max.	
Forward voltage	$I_F=900\text{A}$, $V_{GE}=0\text{V}$ $T_{vj}=25^{\circ}\text{C}$ $I_F=900\text{A}$, $V_{GE}=0\text{V}$ $T_{vj}=125^{\circ}\text{C}$ $I_F=900\text{A}$, $V_{GE}=0\text{V}$ $T_{vj}=175^{\circ}\text{C}$	V_F		2.05 2.25 2.25	2.35	V
Peak reverse recovery current	$I_F=900\text{A}$ $T_{vj}=25^{\circ}\text{C}$ $-di_F/dt=7500\text{A}/\mu\text{s}$ ($T_{vj}=175^{\circ}\text{C}$) $T_{vj}=125^{\circ}\text{C}$ $V_R=600\text{V}$, $V_{GE}=-15\text{V}$ $T_{vj}=175^{\circ}\text{C}$	I_{RM}		512 544 556		A
Recovered charge	$I_F=900\text{A}$ $T_{vj}=25^{\circ}\text{C}$ $-di_F/dt=7500\text{A}/\mu\text{s}$ ($T_{vj}=175^{\circ}\text{C}$) $T_{vj}=125^{\circ}\text{C}$ $V_R=600\text{V}$, $V_{GE}=-15\text{V}$ $T_{vj}=175^{\circ}\text{C}$	Q_F		85 148 189		μC
Reverse recovered energy	$I_F=900\text{A}$ $T_{vj}=25^{\circ}\text{C}$ $-di_F/dt=7500\text{A}/\mu\text{s}$ ($T_{vj}=175^{\circ}\text{C}$) $T_{vj}=125^{\circ}\text{C}$ $V_R=600\text{V}$, $V_{GE}=-15\text{V}$ $T_{vj}=175^{\circ}\text{C}$	E_{rec}		42 68 83		mJ
Thermal resistance, junction to case	per diode	R_{thJC}			0.063	K/W
Temperature under switching conditions	$T_{vj\text{ op}} > 150^{\circ}\text{C}$ is only for operation at overload conditions.	$T_{vj\text{ op}}$	-40		175	$^{\circ}\text{C}$

NTC-Thermistor

Characteristic Values

Parameter	Conditions	Symbol	Value			Unit
			Min.	Typ.	Max.	
Rated resistances	$T_c=25^{\circ}\text{C}$, $\pm 3\%$	R_{25}		5.0		$\text{K } \Omega$
B-value	$R_2 = R_{25}\exp[B_{25/50}(1/T_2 - 1/(298,15 \text{ K}))]$	$B_{25/50}$		3375		K
B-value	$R_2 = R_{25}\exp[B_{25/80}(1/T_2 - 1/(298,15 \text{ K}))]$	$B_{25/80}$		3425		K
B-value	$R_2 = R_{25}\exp[B_{25/100}(1/T_2 - 1/(298,15 \text{ K}))]$	$B_{25/100}$		3443		K

Module

Parameter	Conditions	Symbol	Value			Unit
Isolation test voltage	RMS, $f=50\text{Hz}$, $t=1\text{min}$	V_{ISOL}		3400		V
Internal isolation	basic insulation (class 1, IEC 61140)			Al_2O_3		
Comperative tracking index		CTI		>200		
RTI Elec.	housing	RTI		140		$^{\circ}\text{C}$
Stray inductance module		L_{sCE}		20		nH
Storage temperature		T_{stg}	-40		125	$^{\circ}\text{C}$
Mounting torque for module mounting		M	3.0		6.0	Nm
Terminal Connection Torque		M	3.0		6.0	Nm
Weight		W		357		g

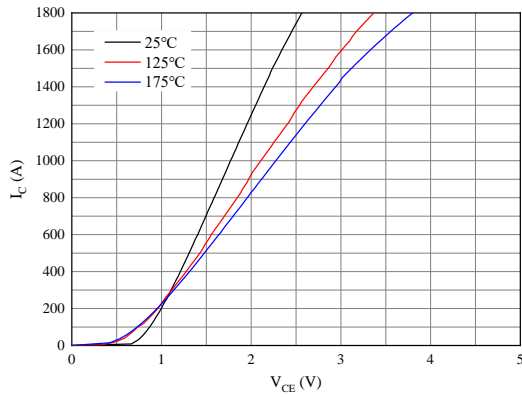

Fig 1. Typical output characteristics ($V_{GE}=15V$)

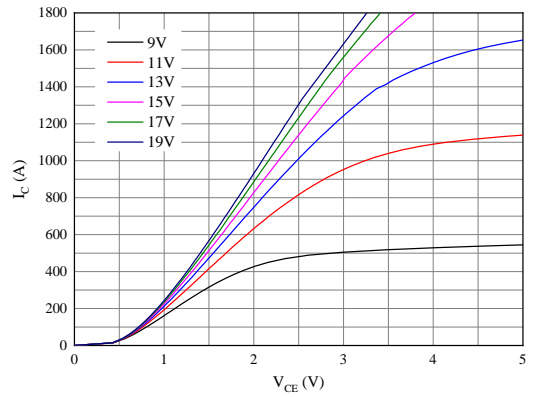

Fig 2. Typical output characteristics ($T_{vj}=175^{\circ}C$)

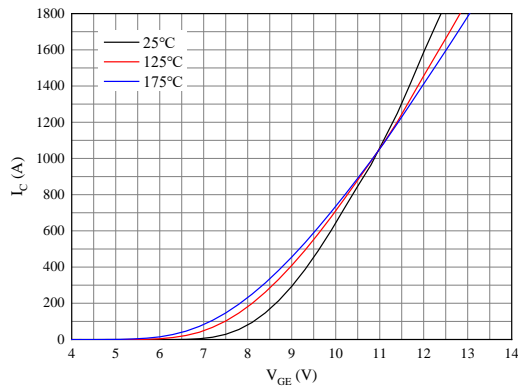

Fig 3. Typical transfer characteristic ($V_{CE}=20V$)

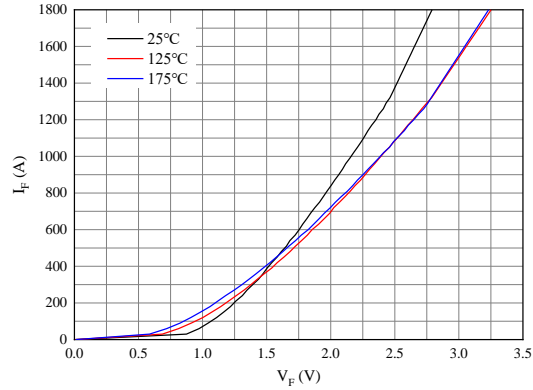

Fig 4. Forward characteristic of Diode

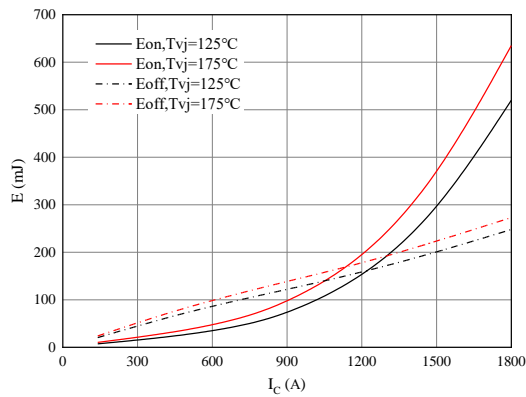

Fig 5. Switching losses of IGBT

$V_{GE}=\pm 15V$, $R_{Gon}=0.5\Omega$, $R_{Goff}=0.5\Omega$, $V_{CE}=600V$

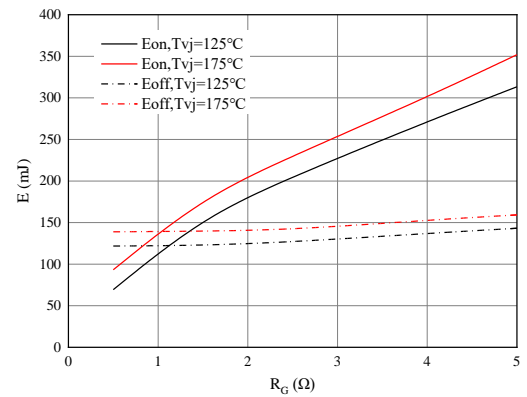

Fig 6. Switching losses of IGBT

$V_{GE}=\pm 15V$, $I_C=900A$, $V_{CE}=600V$

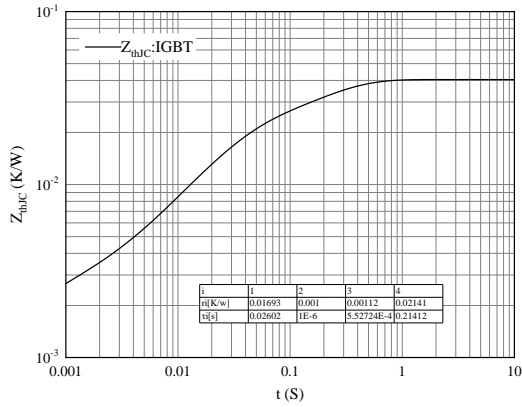

Fig 7. Transient thermal impedance IGBT, Inverter

$Z_{thjC}=f(t)$

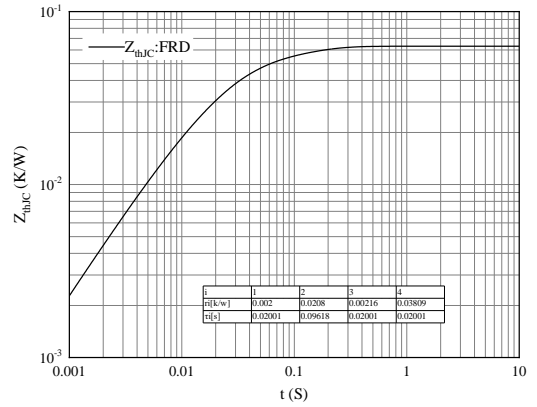

Fig 8. Transient thermal impedance FRD, Inverter

$Z_{thjC}=f(t)$

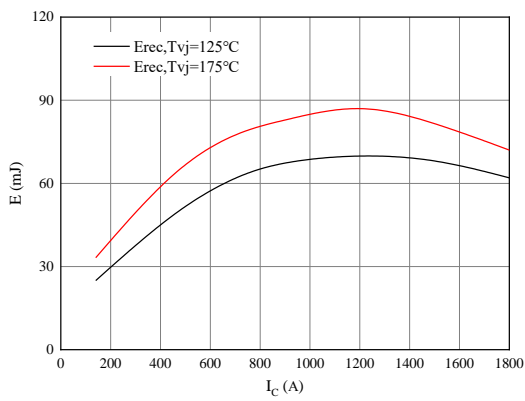

Fig 9. Switching losses of Diode

$R_{Gon}=0.5\Omega, V_{CE}=600V$

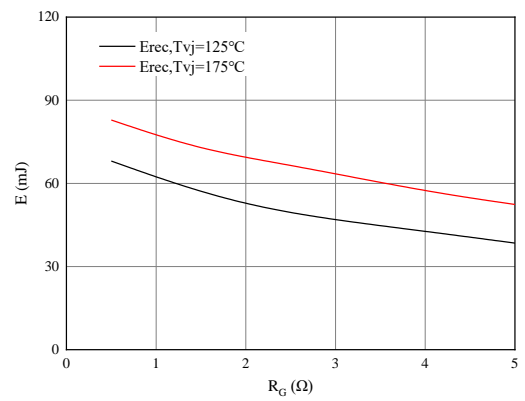

Fig 10. Switching losses of Diode

$I_F=900A, V_{CE}=600V$

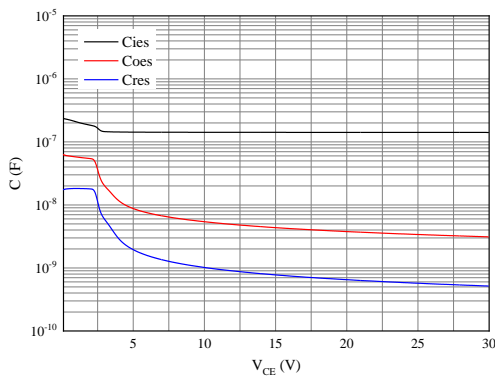

Fig 11. Capacitance characteristic

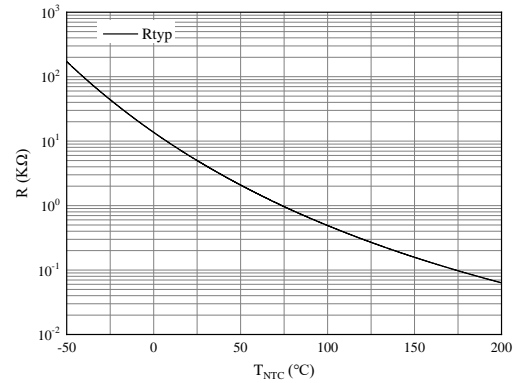
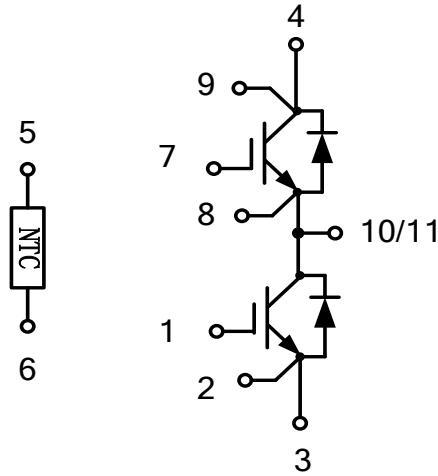

Fig 12. NTC-Thermistor-temperature characteristic

Circuit diagram



Package outlines

