

34mm Half Bridge IGBT Module

$V_{CES}=1700V$, $I_{C\ nom}=100A$ / $I_{CRM}=200A$

Electrical characteristics :

- 1700V Trench /Field Stop process
- Low switching losses
- V_{cesat} has a positive temperature coefficient

Applications:

- Variable Frequency Drive
- UPS
- Servo drive
- inverter

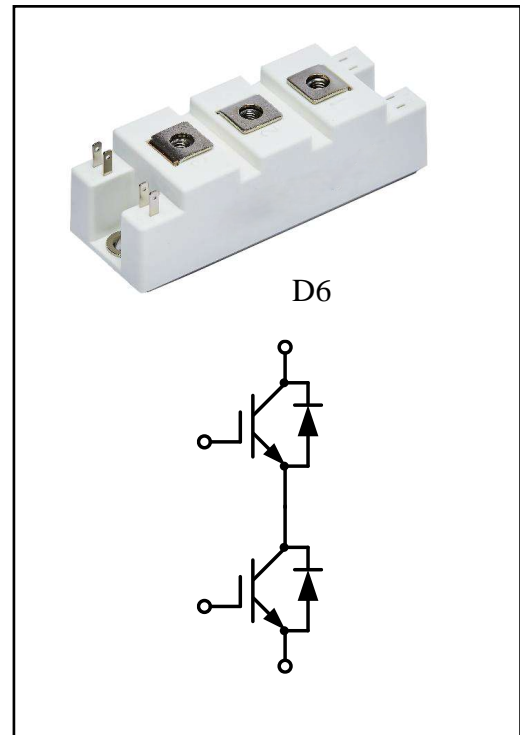

IGBT, Inverter

Maximum Ratings

Parameter	Conditions	Symbol	Value	Unit
Collector-Emitter voltage	$T_{vj}=25^{\circ}C$	V_{CES}	1700	V
Continuous DC collector current	$T_C=100^{\circ}C$, $T_{vj\ max}=175^{\circ}C$	$I_{C\ nom}$	100	A
Repetitive peak collector current	$t_p=1\ ms$	I_{CRM}	200	A
Total power dissipation	$T_C = 25^{\circ}C$, $T_{vj\ max} = 175^{\circ}C$	P_{tot}	789	W
Gate emitter voltage		V_{GE}	± 20	V

Characteristic Values

Parameter	Conditions	Symbol	Value			Unit	
			Min.	Typ.	Max.		
Collector-Emitter saturation voltage	$V_{GE}=15V, I_C=100A$	$T_{vj}=25^{\circ}C$	V_{CEsat}	1.81	2.30	V	
	$V_{GE}=15V, I_C=100A$	$T_{vj}=125^{\circ}C$		2.10			
	$V_{GE}=15V, I_C=100A$	$T_{vj}=150^{\circ}C$		2.16			
Gate-Emitter threshold voltage	$I_C=6mA, V_{GE}=V_{CE}$	$T_{vj}=25^{\circ}C$	$V_{GE(th)}$	5.10	5.70	6.30	
Internal gate resistor			R_{Gint}		5.10		Ω
Input capacitance	$f=1\text{ MHz}, V_{CE}=25\text{ V}, V_{GE}=0\text{ V}$	$T_{vj}=25^{\circ}C$	C_{ies}		13.60		nF
Reverse transfer capacitance			C_{res}		0.40		
Collector-emitter cut-off current	$V_{CE}=1700V, V_{GE}=0\text{ V}$	$T_{vj}=25^{\circ}C$	I_{CES}			1	mA
Gate-emitter leakage current	$V_{CE}=0\text{ V}, V_{GE}=20\text{ V}$	$T_{vj}=25^{\circ}C$	I_{GES}			100	nA
Turn-on delay time	$I_C=100A, V_{CE}=900\text{ V}$ $V_{GE}=\pm 15\text{ V}, R_G=1\Omega$ (inductive load)	$T_{vj}=25^{\circ}C$	$t_{d\ on}$		154		
		$T_{vj}=125^{\circ}C$			166		
		$T_{vj}=150^{\circ}C$			169		
Rise time	$I_C=100A, V_{CE}=900\text{ V}$ $V_{GE}=\pm 15\text{ V}, R_G=1\Omega$ (inductive load)	$T_{vj}=25^{\circ}C$	t_r		33		ns
		$T_{vj}=125^{\circ}C$			36		
		$T_{vj}=150^{\circ}C$			40		
Turn-off delay time	$I_C=100A, V_{CE}=900\text{ V}$ $V_{GE}=\pm 15\text{ V}, R_G=1\Omega$ (inductive load)	$T_{vj}=25^{\circ}C$	$t_{d\ off}$		291		
		$T_{vj}=125^{\circ}C$			330		
		$T_{vj}=150^{\circ}C$			343		
Fall time	$I_C=100A, V_{CE}=900\text{ V}$ $V_{GE}=\pm 15\text{ V}, R_G=1\Omega$ (inductive load)	$T_{vj}=25^{\circ}C$	t_f		383		
		$T_{vj}=125^{\circ}C$			211		
		$T_{vj}=150^{\circ}C$			224		
Turn-on energy loss per pulse	$I_C=100A, V_{CE}=900\text{ V}$ $V_{GE}=\pm 15\text{ V}, R_G=1\Omega$ (inductive load)	$T_{vj}=25^{\circ}C$	E_{on}		11.22		mJ
		$T_{vj}=125^{\circ}C$			14.01		
		$T_{vj}=150^{\circ}C$			15.13		
Turn-off energy loss per pulse	$I_C=100A, V_{CE}=900\text{ V}$ $V_{GE}=\pm 15\text{ V}, R_G=1\Omega$ (inductive load)	$T_{vj}=25^{\circ}C$	E_{off}		17.73		
		$T_{vj}=125^{\circ}C$			20.54		
		$T_{vj}=150^{\circ}C$			20.17		
SC data	$V_{GE}\leq 15V, V_{ce}=900V$ $V_{CEmax}=V_{CES}-L_{sCE}\cdot di/dt$ $t_p\leq 10\mu s, T_{vj}=150^{\circ}C$		I_{SC}		665		A
Thermal resistance, junction to case	per IGBT		R_{thJC}			0.19	K/W
Temperature under switching conditions			$T_{vj\ op}$	-40		150	$^{\circ}C$

Diode, Inverter

Maximum Ratings

Parameter	Conditions	Symbol	Value	Unit
Repetitive peak reverse voltage	$T_{vj}=25^{\circ}\text{C}$	V_{RRM}	1700	V
Continuous DC forward current		I_F	100	A
Repetitive peak forward current	$t_p=1\text{ms}$	I_{FRM}	200	A
I^2t -value	$t_p=10\text{ms}$, $\sin 180^{\circ}$, $T_j=125^{\circ}\text{C}$	I^2t	3000	A^2s

Characteristic Values

Parameter	Conditions	Symbol	Value			Unit
			Min.	Typ.	Max.	
Forward voltage	$I_F=100\text{A}$, $V_{GE}=0\text{V}$ $T_{vj}=25^{\circ}\text{C}$	V_F		2.08	2.60	V
	$I_F=100\text{A}$, $V_{GE}=0\text{V}$ $T_{vj}=125^{\circ}\text{C}$		2.40			
	$I_F=100\text{A}$, $V_{GE}=0\text{V}$ $T_{vj}=150^{\circ}\text{C}$		2.39			
Peak reverse recovery current	$I_F=100\text{A}$ $T_{vj}=25^{\circ}\text{C}$	I_{RM}		74		A
	$-\text{di}_F/\text{dt}=1975\text{A}/\mu\text{s}$ ($T_{vj}=150^{\circ}\text{C}$) $T_{vj}=125^{\circ}\text{C}$		77			
	$V_R=900\text{V}$, $V_{GE}=-15\text{V}$ $T_{vj}=150^{\circ}\text{C}$		74			
Recovered charge	$I_F=100\text{A}$ $T_{vj}=25^{\circ}\text{C}$	Q_r		9.0		μC
	$-\text{di}_F/\text{dt}=1975\text{A}/\mu\text{s}$ ($T_{vj}=150^{\circ}\text{C}$) $T_{vj}=125^{\circ}\text{C}$		17.3			
	$V_R=900\text{V}$, $V_{GE}=-15\text{V}$ $T_{vj}=150^{\circ}\text{C}$		20.9			
Reverse recovered energy	$I_F=100\text{A}$ $T_{vj}=25^{\circ}\text{C}$	E_{rec}		4.73		mJ
	$-\text{di}_F/\text{dt}=1975\text{A}/\mu\text{s}$ ($T_{vj}=150^{\circ}\text{C}$) $T_{vj}=125^{\circ}\text{C}$		17.34			
	$V_R=900\text{V}$, $V_{GE}=-15\text{V}$ $T_{vj}=150^{\circ}\text{C}$		20.88			
Thermal resistance, junction to case	per diode	R_{thJC}			0.38	K/W
Temperature under switching conditions		$T_{vj\text{ op}}$	-40		150	$^{\circ}\text{C}$

Module

Parameter	Conditions	Symbol	Value			Unit
Isolation test voltage	RMS, $f=50\text{Hz}$, $t=1\text{min}$	V_{ISOL}	4000			V
Internal isolation			Al_2O_3			
Storage temperature		T_{stg}	-40		125	$^{\circ}\text{C}$
Mounting torque for modul mounting		M	3.0		6.0	Nm
Weight		W		155		g

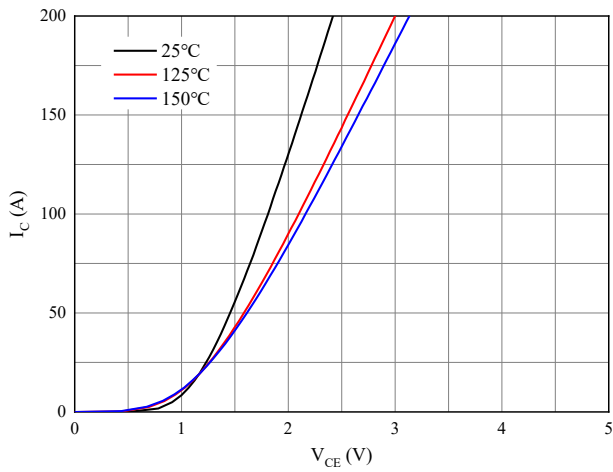

Fig 1. Typical output characteristics ($V_{GE}=15V$)

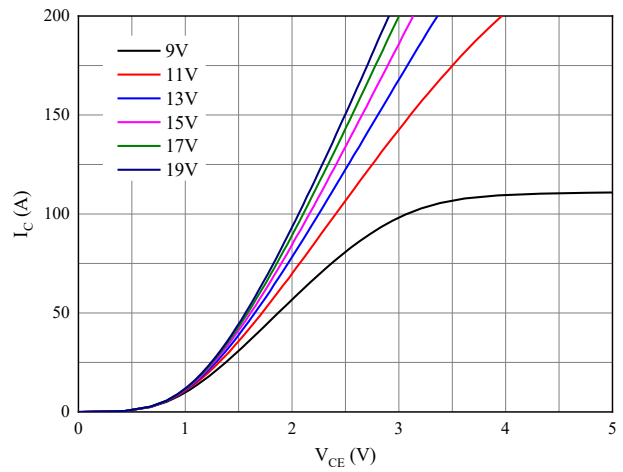

Fig 2. Typical output characteristics ($T_{vj}=150^{\circ}C$)

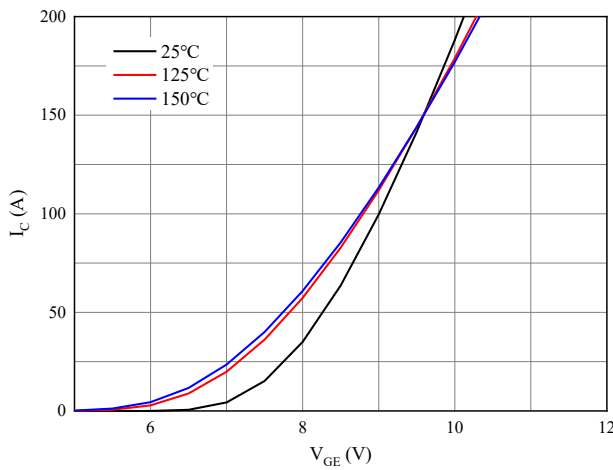

Fig 3. Typical transfer characteristic ($V_{CE}=20V$)

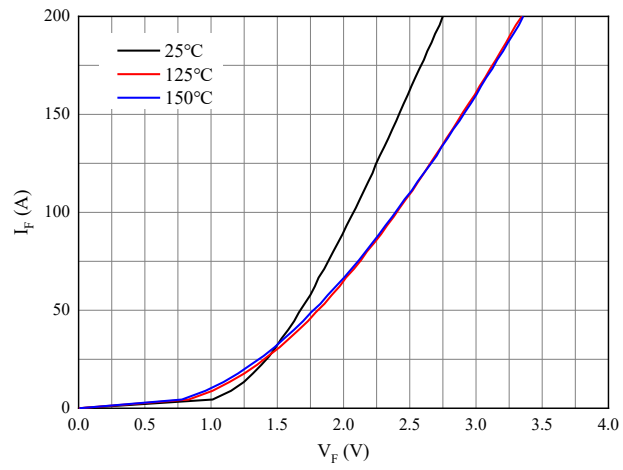

Fig 4. Forward characteristic of Diode

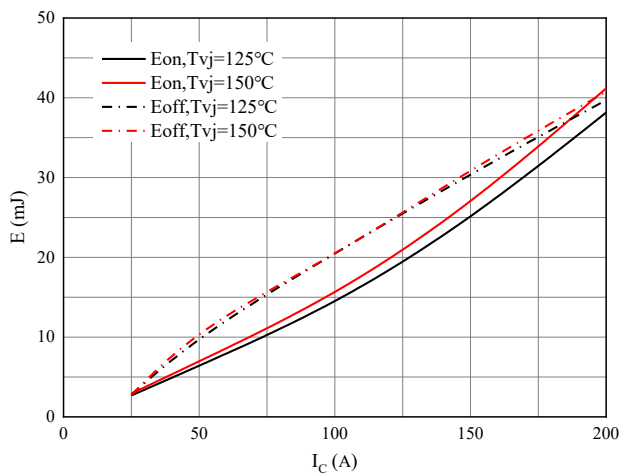

Fig 5. Switching losses of IGBT
 $V_{GE}=\pm 15V, R_{Gon}=1\Omega, R_{Goff}=1\Omega, V_{CE}=900V$

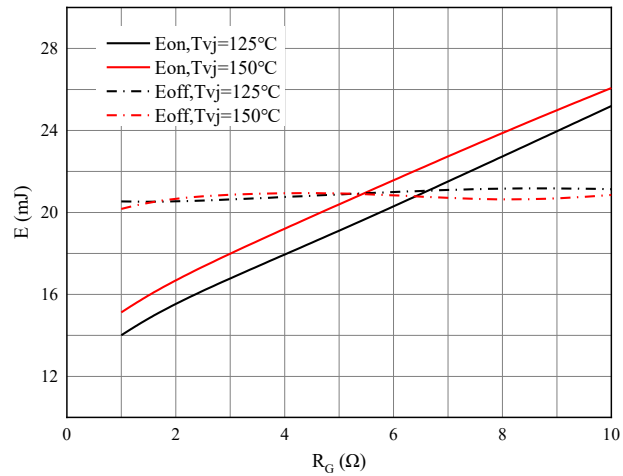

Fig 6. Switching losses of IGBT
 $V_{GE}=\pm 15V, I_C=100A, V_{CE}=900V$

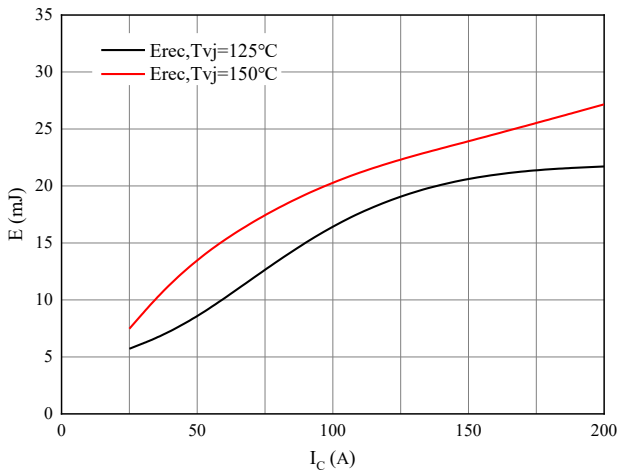

Fig 7. Switching losses of Diode
 $R_{Gon}=1\Omega, V_{CE}=900\text{V}$

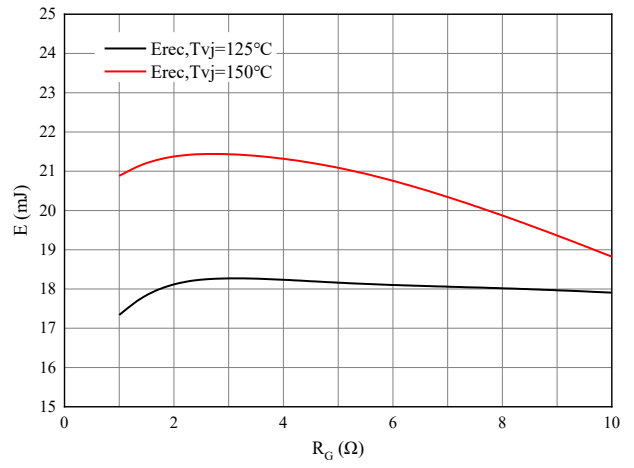

Fig 8. Switching losses of Diode
 $I_F=100\text{A}, V_{CE}=900\text{V}$

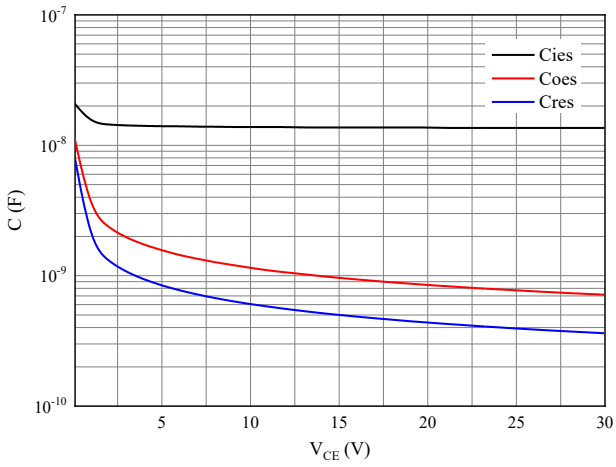
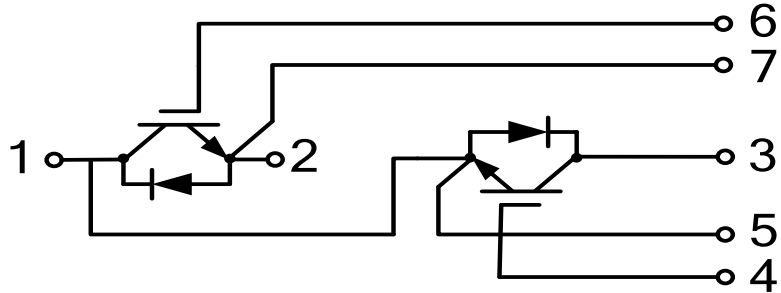

Fig 9. Capacitance characteristic

Circuit diagram



Package outlines

