

62mm Half Bridge IGBT Module

$V_{CES} = 1700V$, $I_{C\ nom} = 200A$ / $I_{CRM} = 400A$

Electrical characteristics :

- 1700V Trench /Field Stop process
- Low switching losses
- V_{cesat} has a positive temperature coefficient

Applications:

- Variable Frequency Drive
- UPS
- Servo drive
- inverter

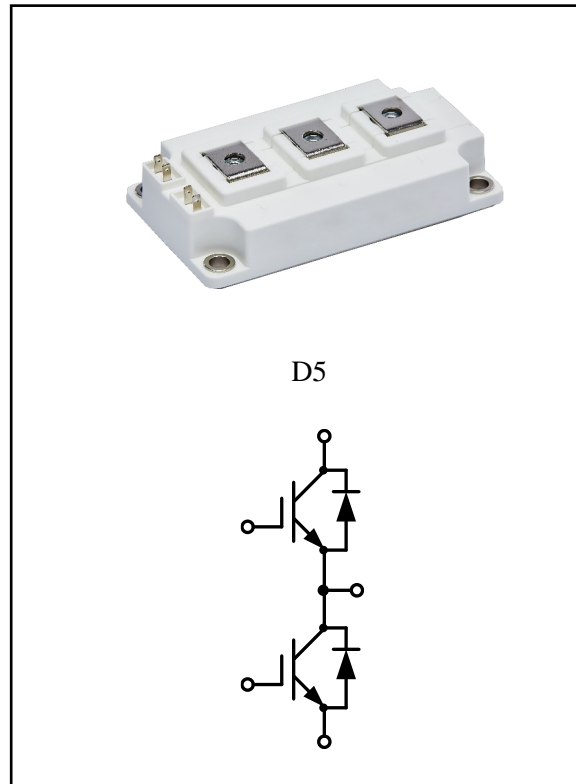

IGBT, Inverter

Maximum Ratings

Parameter	Conditions	Symbol	Value	Unit
Collector-Emitter voltage	$T_{vj} = 25^{\circ}C$	V_{CES}	1700	V
Continuous DC collector current	$T_C = 100^{\circ}C$, $T_{vj\ max} = 175^{\circ}C$	$I_{C\ nom}$	200	A
Repetitive peak collector current	$t_p = 1\ ms$	I_{CRM}	400	A
Total power dissipation	$T_C = 25^{\circ}C$, $T_{vj\ max} = 175^{\circ}C$	P_{tot}	1250	W
Gate emitter voltage		V_{GE}	± 20	V

Characteristic Values

Parameter	Conditions	Symbol	Value			Unit	
			Min.	Typ.	Max.		
Collector-Emitter saturation voltage	$V_{GE}=15V, I_C=200A$ $V_{GE}=15V, I_C=200A$ $V_{GE}=15V, I_C=200A$	$T_{vj}=25^{\circ}C$ $T_{vj}=125^{\circ}C$ $T_{vj}=150^{\circ}C$	V_{CEsat}	1.93 2.22 2.39	2.50	V	
Gate-Emitter threshold voltage	$I_C=8mA, V_{GE}=V_{CE}$	$T_{vj}=25^{\circ}C$	$V_{GE(th)}$	5.10	5.70 6.30		
Internal gate resistor			R_{Gint}	2.58		Ω	
Gate charge	$V_{GE}=-15V...+15V$		Q_G	1.90		μC	
Input capacitance	$f=1MHz, V_{CE}=25V, V_{GE}=0V$	$T_{vj}=25^{\circ}C$	C_{ies}	27.18		nF	
Reverse transfer capacitance			C_{res}	0.80			
Collector-emitter cut-off current	$V_{CE}=1700V, V_{GE}=0V$	$T_{vj}=25^{\circ}C$	I_{CES}		2	mA	
Gate-emitter leakage current	$V_{CE}=0V, V_{GE}=20V$	$T_{vj}=25^{\circ}C$	I_{GES}		200	nA	
Turn-on delay time	$I_C=200A, V_{CE}=900V$ $V_{GE}=\pm 15V, R_G=3.3\Omega$ (inductive load)	$T_{vj}=25^{\circ}C$ $T_{vj}=125^{\circ}C$ $T_{vj}=150^{\circ}C$	$t_{d on}$	194 212 224		ns	
Rise time	$I_C=200A, V_{CE}=900V$ $V_{GE}=\pm 15V, R_G=3.3\Omega$ (inductive load)	$T_{vj}=25^{\circ}C$ $T_{vj}=125^{\circ}C$ $T_{vj}=150^{\circ}C$	t_r	51 55 57			
Turn-off delay time	$I_C=200A, V_{CE}=900V$ $V_{GE}=\pm 15V, R_G=3.3\Omega$ (inductive load)	$T_{vj}=25^{\circ}C$ $T_{vj}=125^{\circ}C$ $T_{vj}=150^{\circ}C$	$t_{d off}$	430 489 506			
Fall time	$I_C=200A, V_{CE}=900V$ $V_{GE}=\pm 15V, R_G=3.3\Omega$ (inductive load)	$T_{vj}=25^{\circ}C$ $T_{vj}=125^{\circ}C$ $T_{vj}=150^{\circ}C$	t_f	303 352 368			
Turn-on energy loss per pulse	$I_C=200A, V_{CE}=900V$ $V_{GE}=\pm 15V, R_G=3.3\Omega$ (inductive load)	$T_{vj}=25^{\circ}C$ $T_{vj}=125^{\circ}C$ $T_{vj}=150^{\circ}C$	E_{on}	31.88 40.73 43.77			mJ
Turn-off energy loss per pulse	$I_C=200A, V_{CE}=900V$ $V_{GE}=\pm 15V, R_G=3.3\Omega$ (inductive load)	$T_{vj}=25^{\circ}C$ $T_{vj}=125^{\circ}C$ $T_{vj}=150^{\circ}C$	E_{off}	38.04 46.56 49.29			
SC data	$V_{GE}\leq 15V, V_{cc}=1000V$ $V_{CEmax}=V_{CES}-L_{sCE}\cdot di/dt$	$t_p\leq 10\mu s, T_{vj}=150^{\circ}C$	I_{sc}	1230		A	
Thermal resistance, junction to case	per IGBT		R_{thJC}		0.12	K/W	
Temperature under switching conditions			$T_{vj op}$	-40	150	$^{\circ}C$	

Diode, Inverter

Maximum Ratings

Parameter	Conditions	Symbol	Value	Unit
Repetitive peak reverse voltage	$T_{vj}=25^{\circ}\text{C}$	V_{RRM}	1700	V
Continuous DC forward current		I_F	200	A
Repetitive peak forward current	$t_p=1\text{ms}$	I_{FRM}	400	A
I^2t -value	$t_p=10\text{ms}$, $\sin 180^{\circ}$, $T_j=125^{\circ}\text{C}$	I^2t	10000	A^2s

Characteristic Values

Parameter	Conditions	Symbol	Value			Unit
			Min.	Typ.	Max.	
Forward voltage	$I_F=200\text{A}$, $V_{GE}=0\text{V}$ $T_{vj}=25^{\circ}\text{C}$	V_F		2.07	2.50	V
	$I_F=200\text{A}$, $V_{GE}=0\text{V}$ $T_{vj}=125^{\circ}\text{C}$			2.28		
	$I_F=200\text{A}$, $V_{GE}=0\text{V}$ $T_{vj}=150^{\circ}\text{C}$			2.24		
Peak reverse recovery current	$I_F=200\text{A}$ $T_{vj}=25^{\circ}\text{C}$	I_{RM}		109		A
	$-\text{di}_F/\text{dt}=2430\text{A}/\mu\text{s}$ ($T_{vj}=150^{\circ}\text{C}$) $T_{vj}=125^{\circ}\text{C}$			122		
	$V_R=900\text{V}$, $V_{GE}=-15\text{V}$ $T_{vj}=150^{\circ}\text{C}$			122		
Recovered charge	$I_F=200\text{A}$ $T_{vj}=25^{\circ}\text{C}$	Q_r		22.80		μC
	$-\text{di}_F/\text{dt}=2430\text{A}/\mu\text{s}$ ($T_{vj}=150^{\circ}\text{C}$) $T_{vj}=125^{\circ}\text{C}$			38.70		
	$V_R=900\text{V}$, $V_{GE}=-15\text{V}$ $T_{vj}=150^{\circ}\text{C}$			39.90		
Reverse recovered energy	$I_F=200\text{A}$ $T_{vj}=25^{\circ}\text{C}$	E_{rec}		12.70		mJ
	$-\text{di}_F/\text{dt}=2430\text{A}/\mu\text{s}$ ($T_{vj}=150^{\circ}\text{C}$) $T_{vj}=125^{\circ}\text{C}$			23.07		
	$V_R=900\text{V}$, $V_{GE}=-15\text{V}$ $T_{vj}=150^{\circ}\text{C}$			23.26		
Thermal resistance, junction to case	per diode	R_{thJC}			0.16	K/W
Temperature under switching conditions		$T_{vj\text{op}}$	-40		150	$^{\circ}\text{C}$

Module

Parameter	Conditions	Symbol	Value			Unit
Isolation test voltage	RMS, $f=50\text{Hz}$, $t=1\text{min}$	V_{ISOL}	4000			V
Internal isolation			Al_2O_3			
Storage temperature		T_{stg}	-40		125	$^{\circ}\text{C}$
Mounting torque for modul mounting		M	3.0		6.0	Nm
Weight		W		318		g

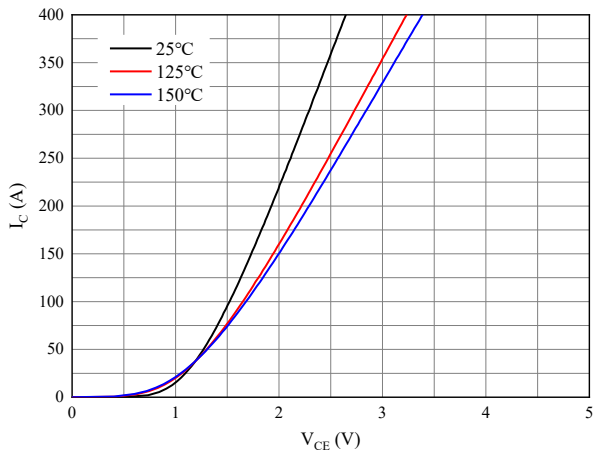

Fig 1. Typical output characteristics ($V_{GE}=15V$)

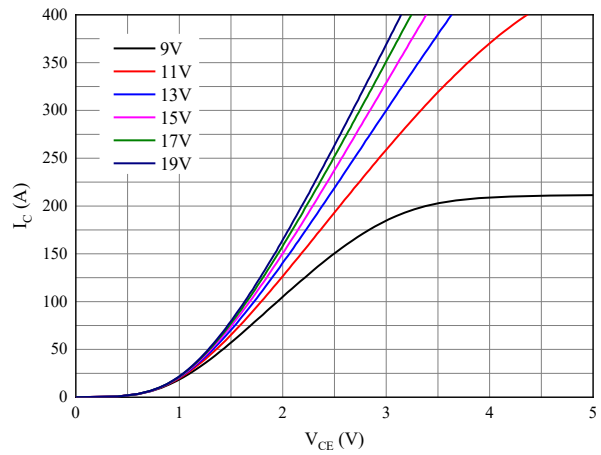

Fig 2. Typical output characteristics ($T_{vj}=150^{\circ}C$)

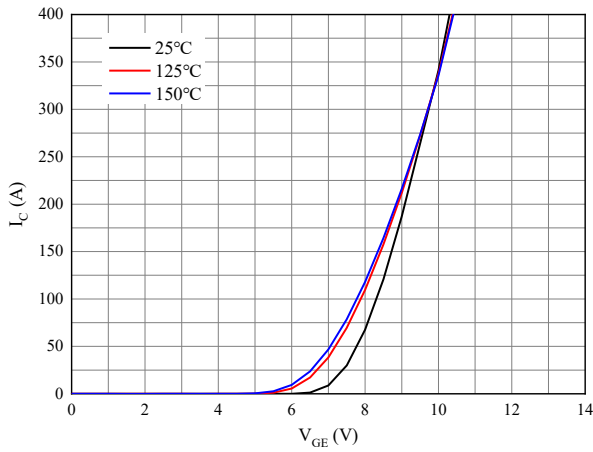

Fig 3. Typical transfer characteristic ($V_{CE}=20V$)

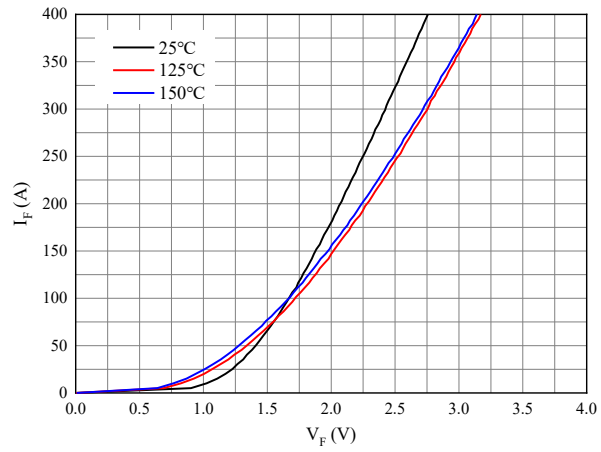

Fig 4. Forward characteristic of Diode

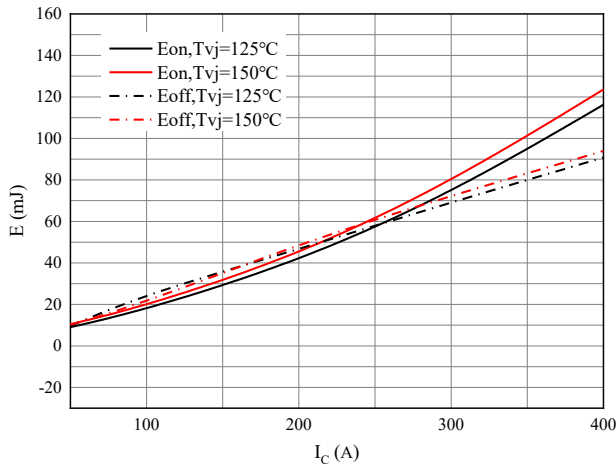

Fig 5. Switching losses of IGBT
 $V_{GE}=\pm 15V$, $R_{Gon}=3.3\Omega$, $R_{Goff}=3.3\Omega$, $V_{CE}=900V$

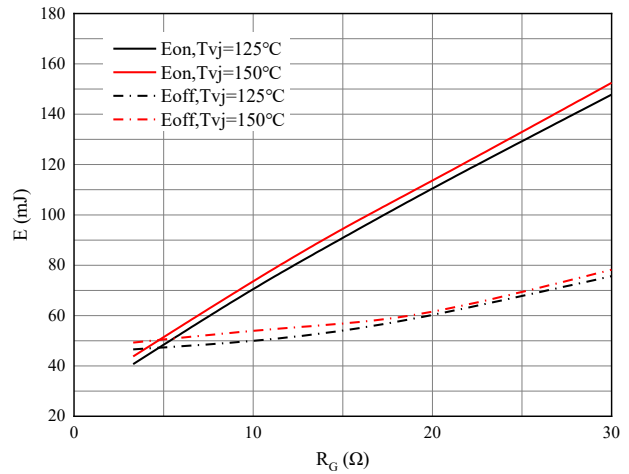

Fig 6. Switching losses of IGBT
 $V_{GE}=\pm 15V$, $I_C=200A$, $V_{CE}=900V$

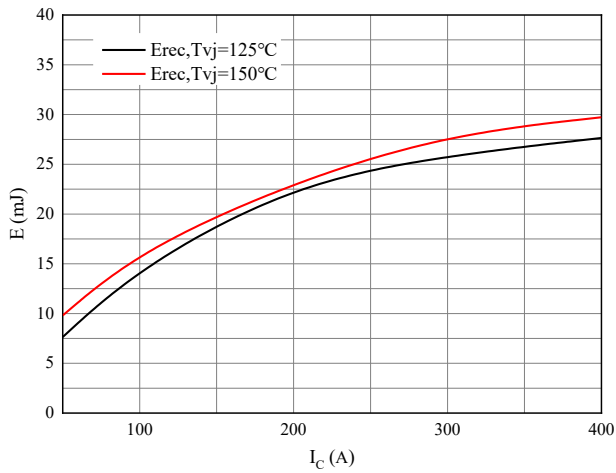

Fig 7. Switching losses of Diode
 $R_{Gon}=3.3\Omega, V_{CE}=900V$

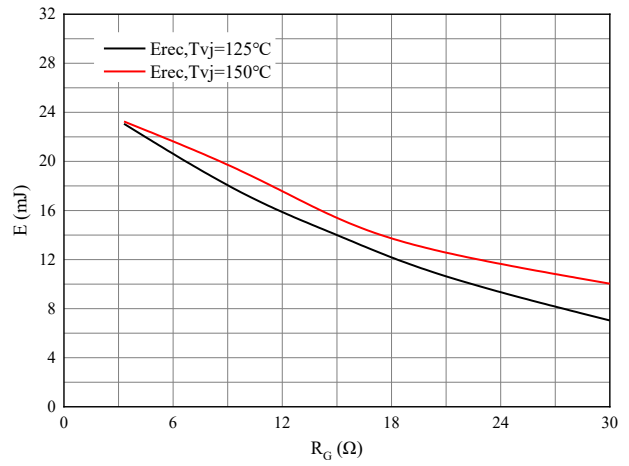

Fig 8. Switching losses of Diode
 $I_F=200A, V_{CE}=900V$

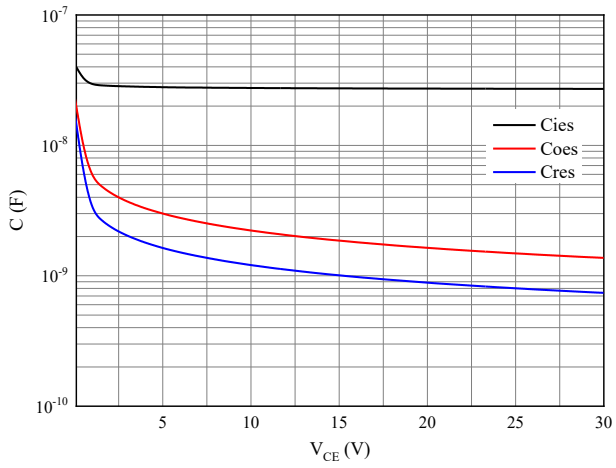
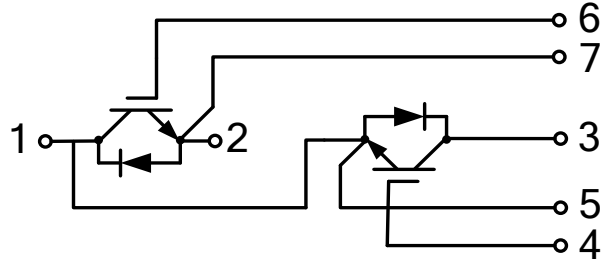

Fig 9. Capacitance characteristic

Circuit diagram



Package outlines

