

62mm Half Bridge IGBT Module

$V_{CES} = 1700V$, $I_{C\ nom} = 400A$ / $I_{CRM} = 800A$

Electrical characteristics :

- 1700V Trench /Field Stop process
- Low switching losses
- V_{cesat} has a positive temperature coefficient

Applications:

- high voltage VFD
- UPS
- Servo drive
- inverter

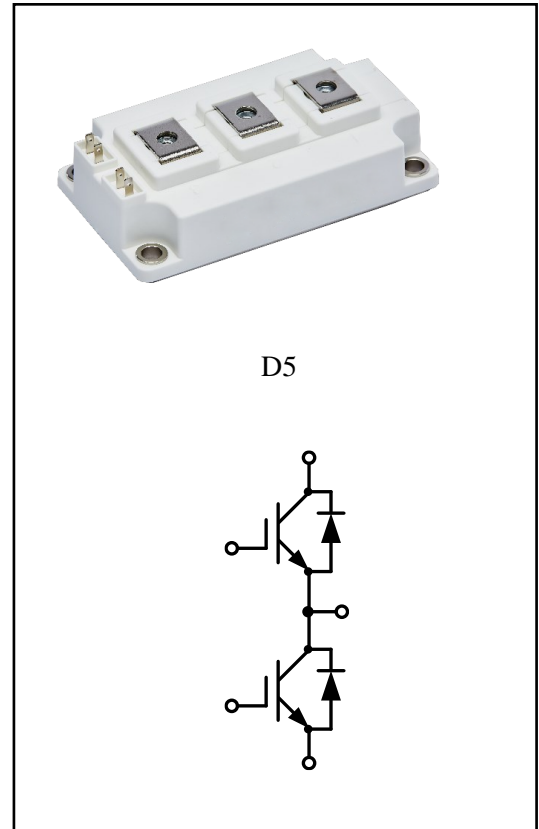

IGBT, Inverter

Maximum Ratings

Parameter	Conditions	Symbol	Value	Unit
Collector-Emitter voltage	$T_{vj} = 25^{\circ}C$	V_{CES}	1700	V
Continuous DC collector current	$T_C = 80^{\circ}C$, $T_{vj\ max} = 150^{\circ}C$	$I_{C\ nom}$	400	A
Repetitive peak collector current	$t_p = 1\ ms$	I_{CRM}	800	A
Gate emitter voltage		V_{GE}	± 20	V

Characteristic Values

Parameter	Conditions	Symbol	Value			Unit
			Min.	Typ.	Max.	
Collector-Emitter saturation voltage	$V_{GE}=15V, I_C=400A$ $V_{GE}=15V, I_C=400A$ $V_{GE}=15V, I_C=400A$	$T_{vj}=25^{\circ}C$ $T_{vj}=125^{\circ}C$ $T_{vj}=150^{\circ}C$	V_{CEsat}	2.08 2.49 2.57	2.50	V
Gate-Emitter threshold voltage	$I_C=18mA, V_{GE}=V_{CE}$	$T_{vj}=25^{\circ}C$	$V_{GE(th)}$	5.2 5.85	6.4	
Internal gate resistor			R_{Gint}	1.6		Ω
Input capacitance	$f=1MHz, V_{CE}=25V, V_{GE}=0V$	$T_{vj}=25^{\circ}C$	C_{ies}	33.93		nF
Reverse transfer capacitance			C_{res}	1.27		
Collector-emitter cut-off current	$V_{CE}=1700V, V_{GE}=0V$	$T_{vj}=25^{\circ}C$	I_{CES}		1	mA
Gate-emitter leakage current	$V_{CE}=0V, V_{GE}=20V$	$T_{vj}=25^{\circ}C$	I_{GES}		400	nA
Turn-on delay time	$I_C=400A, V_{CE}=900V$ $V_{GE}=\pm 15V, R_G=1\Omega$ (inductive load)	$T_{vj}=25^{\circ}C$ $T_{vj}=125^{\circ}C$	t_{don}	231 242		ns
Rise time	$I_C=400A, V_{CE}=900V$ $V_{GE}=\pm 15V, R_G=1\Omega$ (inductive load)	$T_{vj}=25^{\circ}C$ $T_{vj}=125^{\circ}C$	t_r	92 105		
Turn-off delay time	$I_C=400A, V_{CE}=900V$ $V_{GE}=\pm 15V, R_G=1\Omega$ (inductive load)	$T_{vj}=25^{\circ}C$ $T_{vj}=125^{\circ}C$	t_{doff}	474 531		
Fall time	$I_C=400A, V_{CE}=900V$ $V_{GE}=\pm 15V, R_G=1\Omega$ (inductive load)	$T_{vj}=25^{\circ}C$ $T_{vj}=125^{\circ}C$	t_f	211 306		
Turn-on energy loss per pulse	$I_C=400A, V_{CE}=900V$ $V_{GE}=\pm 15V, R_G=1\Omega$ (inductive load)	$T_{vj}=25^{\circ}C$ $T_{vj}=125^{\circ}C$	E_{on}	74.95 104.30		mJ
Turn-off energy loss per pulse	$I_C=400A, V_{CE}=900V$ $V_{GE}=\pm 15V, R_G=1\Omega$ (inductive load)	$T_{vj}=25^{\circ}C$ $T_{vj}=125^{\circ}C$	E_{off}	61.39 77.19		
SC data	$V_{GE}\leq 15V, V_{ce}=1000V$ $V_{CEmax}=V_{CES}-L_{sCE}\cdot di/dt \quad t_p\leq 10\mu s, T_{vj}=125^{\circ}C$		I_{sc}	2200		A
Thermal resistance, junction to case	per IGBT		R_{thJC}		0.06	K/W
Temperature under switching conditions			$T_{vj op}$	-40	125	$^{\circ}C$

Diode, Inverter

Maximum Ratings

Parameter	Conditions	Symbol	Value	Unit
Repetitive peak reverse voltage	$T_{vj}=25^{\circ}\text{C}$	V_{RRM}	1700	V
Continuous DC forward current		I_F	400	A
Repetitive peak forward current	$t_p=1\text{ms}$	I_{FRM}	800	A
I^2t -value	$t_p=10\text{ms}$, $\sin 180^{\circ}$, $T_j=125^{\circ}\text{C}$	I^2t	44000	A^2s

Characteristic Values

Parameter	Conditions	Symbol	Value			Unit
			Min.	Typ.	Max.	
Forward voltage	$I_F=400\text{A}$, $V_{GE}=0\text{V}$ $T_{vj}=25^{\circ}\text{C}$	V_F		2.09	2.6	V
	$I_F=400\text{A}$, $V_{GE}=0\text{V}$ $T_{vj}=125^{\circ}\text{C}$		2.33			
	$I_F=400\text{A}$, $V_{GE}=0\text{V}$ $T_{vj}=150^{\circ}\text{C}$		2.29			
Peak reverse recovery current	$I_F=400\text{A}$ $-di_F/dt=3059\text{A}/\mu\text{s}$ ($T_{vj}=125^{\circ}\text{C}$) $V_R=900\text{V}$, $V_{GE}=-15\text{V}$	I_{RM}		282 307		A
Recovered charge	$I_F=400\text{A}$ $-di_F/dt=3059\text{A}/\mu\text{s}$ ($T_{vj}=125^{\circ}\text{C}$) $V_R=900\text{V}$, $V_{GE}=-15\text{V}$	Q_r		55.24 91.88		μC
Reverse recovered energy	$I_F=400\text{A}$ $-di_F/dt=3059\text{A}/\mu\text{s}$ ($T_{vj}=125^{\circ}\text{C}$) $V_R=900\text{V}$, $V_{GE}=-15\text{V}$	E_{rec}		30.70 52.99		mJ
Thermal resistance, junction to case	per diode	R_{thJC}			0.11	K/W
Temperature under switching conditions		$T_{vj\ op}$	-40		125	$^{\circ}\text{C}$

Module

Parameter	Conditions	Symbol	Value			Unit
Isolation test voltage	RMS, $f=50\text{Hz}$, $t=1\text{min}$	V_{ISOL}	4000			V
Internal isolation			Al_2O_3			
Storage temperature		T_{stg}	-40		125	$^{\circ}\text{C}$
Mounting torque for modul mounting		M	3.0		6.0	Nm
Weight		W		308		g

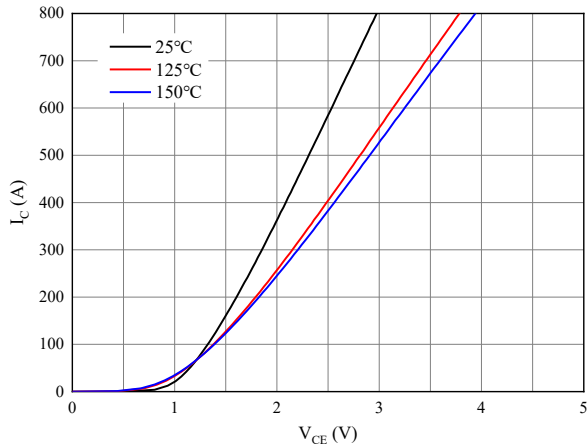

Fig 1. Typical output characteristics ($V_{GE}=15V$)

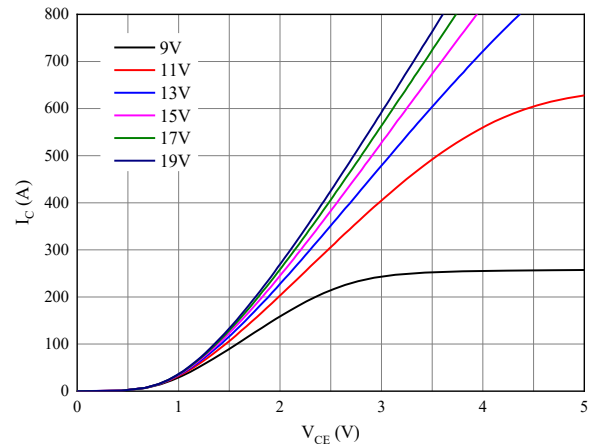

Fig 2. Typical output characteristics ($T_{vj}=150^{\circ}C$)

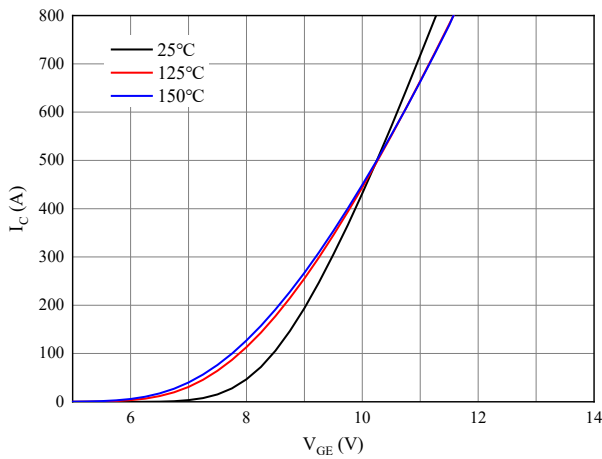

Fig 3. Typical transfer characteristic ($V_{CE}=20V$)

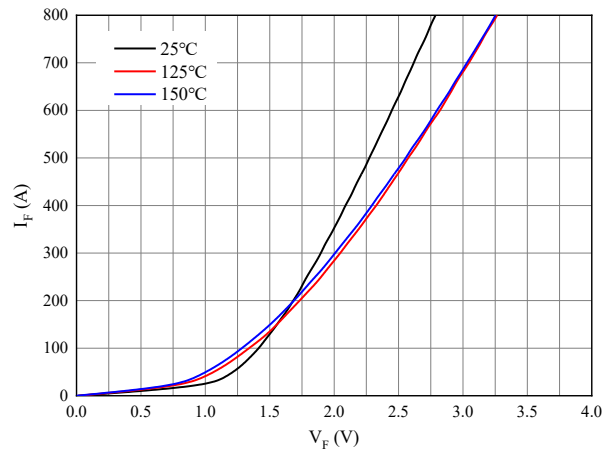

Fig 4. Forward characteristic of Diode

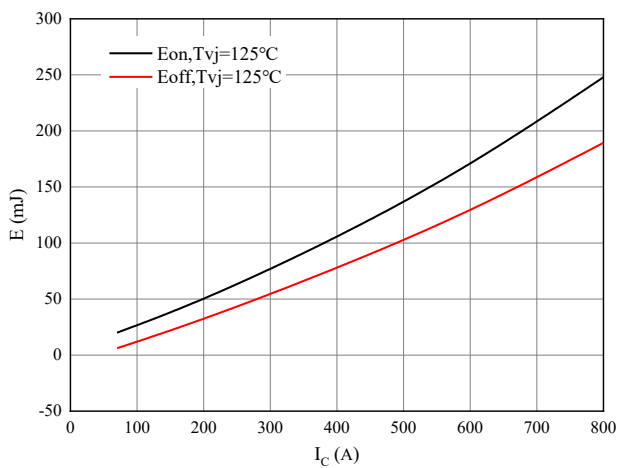

Fig 5. Switching losses of IGBT
 $V_{GE}=\pm 15V$, $R_{Gon}=1\Omega$, $R_{Goff}=1\Omega$, $V_{CE}=900V$

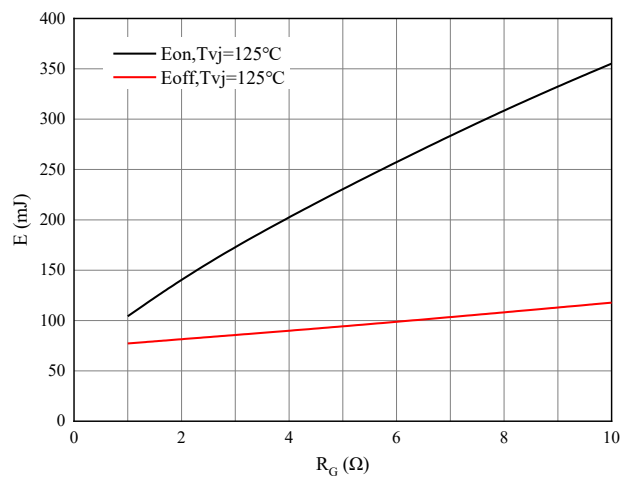

Fig 6. Switching losses of IGBT
 $V_{GE}=\pm 15V$, $I_C=400A$, $V_{CE}=900V$

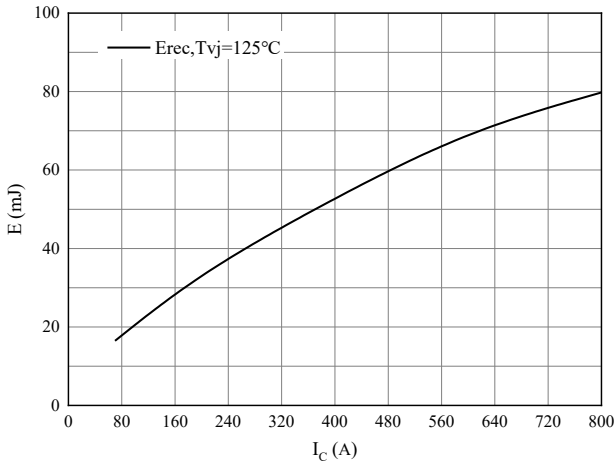

Fig 7. Switching losses of Diode
 $R_{Gon}=1\Omega, V_{CE}=900V$

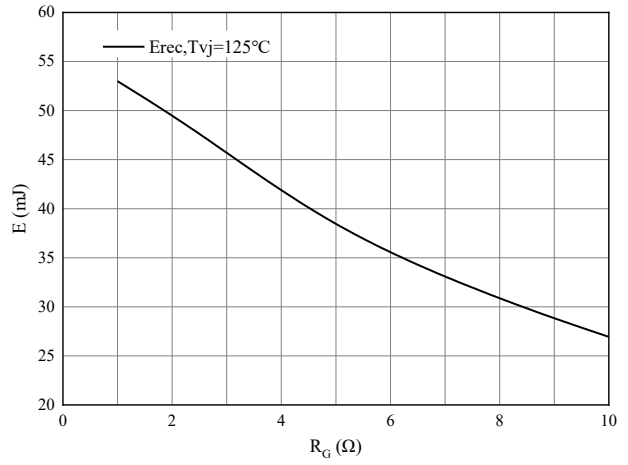

Fig 8. Switching losses of Diode
 $I_F=400A, V_{CE}=900V$

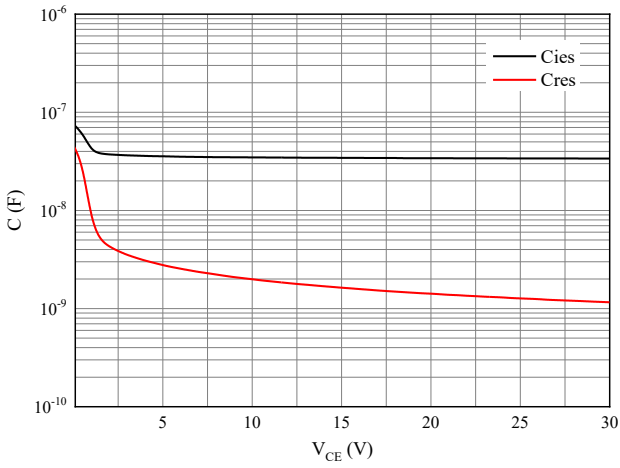
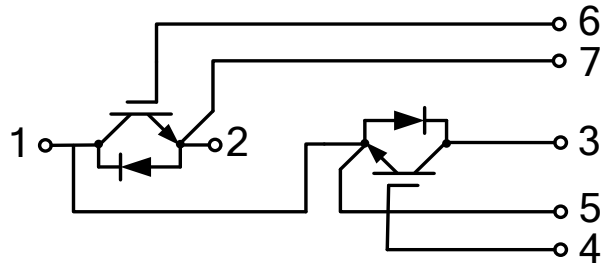

Fig 9. Capacitance characteristic

Circuit diagram



Package outlines

