

## Half Bridge IGBT Module

$V_{CES} = 1700V$ ,  $I_{C\ nom} = 450A / I_{CRM} = 900A$

### Electrical characteristics :

- 1700V Trench /Field Stop process
- Low switching losses
- $V_{cesat}$  has a positive temperature coefficient

### Applications:

- Power Converters
- UPS Systems
- Servo Drives
- Wind Turbines

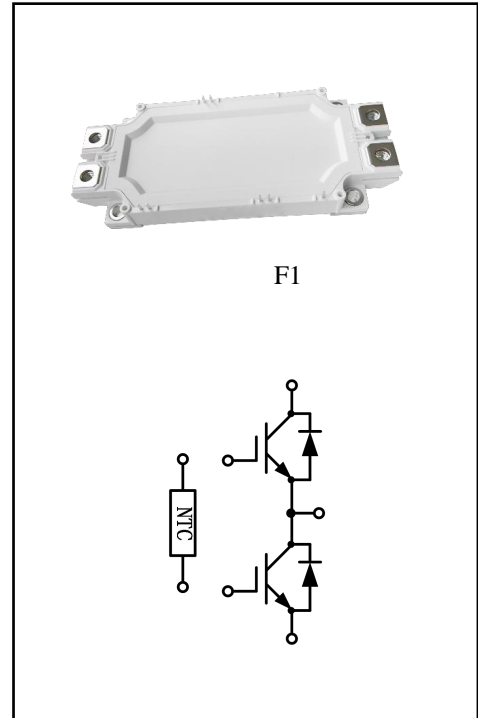

## IGBT, Inverter

### Maximum Ratings

Parameter	Conditions	Symbol	Value	Unit
Collector-Emitter voltage	$T_{vj} = 25^{\circ}C$	$V_{CES}$	1700	V
Continuous DC collector current	$T_C = 100^{\circ}C$ , $T_{vj\ max} = 175^{\circ}C$	$I_{C\ nom}$	450	A
Repetitive peak collector current	$t_p = 1\ ms$	$I_{CRM}$	900	A
Total power dissipation	$T_C = 25^{\circ}C$ , $T_{vj\ max} = 175^{\circ}C$	$P_{tot}$	2140	W
Gate emitter voltage		$V_{GE}$	$\pm 20$	V

## Characteristic Values

Parameter	Conditions	Symbol	Value			Unit
			Min.	Typ.	Max.	
Collector-Emitter saturation voltage	$V_{GE}=15V, I_C=450A$ $V_{GE}=15V, I_C=450A$ $V_{GE}=15V, I_C=450A$	$T_{vj}=25^{\circ}C$ $T_{vj}=125^{\circ}C$ $T_{vj}=150^{\circ}C$	$V_{CEsat}$	1.97 2.35 2.45	2.55	V
Gate-Emitter threshold voltage	$I_C=18mA, V_{GE}=V_{CE}$	$T_{vj}=25^{\circ}C$	$V_{GE(th)}$	4.90	5.50	6.10
Gate charge	$V_{GE}=-15V \dots +15V$		$Q_G$		3.22	$\mu C$
Internal gate resistor	$T_{vj}=25^{\circ}C$		$R_{Gint}$		1.60	$\Omega$
Input capacitance	$f=100KHz, V_{CE}=25V, V_{GE}=0V$	$T_{vj}=25^{\circ}C$	$C_{ies}$		44.00	nF
Reverse transfer capacitance			$C_{res}$		1.30	
Collector-emitter cut-off current	$V_{CE}=1700V, V_{GE}=0V$	$T_{vj}=25^{\circ}C$	$I_{CES}$		2	mA
Gate-emitter leakage current	$V_{CE}=0V, V_{GE}=20V$	$T_{vj}=25^{\circ}C$	$I_{GES}$		200	nA
Turn-on delay time	$I_C=450A, V_{CE}=900V$ $V_{GE}=\pm 15V, R_G=3.3\Omega$ (inductive load)	$T_{vj}=25^{\circ}C$ $T_{vj}=125^{\circ}C$ $T_{vj}=150^{\circ}C$	$t_{don}$		223 237 250	ns
Rise time	$I_C=450A, V_{CE}=900V$ $V_{GE}=\pm 15V, R_G=3.3\Omega$ (inductive load)	$T_{vj}=25^{\circ}C$ $T_{vj}=125^{\circ}C$ $T_{vj}=150^{\circ}C$	$t_r$		109 122 127	
Turn-off delay time	$I_C=450A, V_{CE}=900V$ $V_{GE}=\pm 15V, R_G=3.3\Omega$ (inductive load)	$T_{vj}=25^{\circ}C$ $T_{vj}=125^{\circ}C$ $T_{vj}=150^{\circ}C$	$t_{doff}$		540 589 604	
Fall time	$I_C=450A, V_{CE}=900V$ $V_{GE}=\pm 15V, R_G=3.3\Omega$ (inductive load)	$T_{vj}=25^{\circ}C$ $T_{vj}=125^{\circ}C$ $T_{vj}=150^{\circ}C$	$t_f$		267 355 383	
Turn-on energy loss per pulse	$I_C=450A, V_{CE}=900V$ $V_{GE}=\pm 15V, R_G=3.3\Omega$ $di/dt=2500A/\mu s(T_{vj}=150^{\circ}C)$ (inductive load)	$T_{vj}=25^{\circ}C$ $T_{vj}=125^{\circ}C$ $T_{vj}=150^{\circ}C$	$E_{on}$		120.9 160.7 176.7	
Turn-off energy loss per pulse	$I_C=450A, V_{CE}=900V$ $V_{GE}=\pm 15V, R_G=3.3\Omega$ $du/dt=4900V/\mu s(T_{vj}=150^{\circ}C)$ (inductive load)	$T_{vj}=25^{\circ}C$ $T_{vj}=125^{\circ}C$ $T_{vj}=150^{\circ}C$	$E_{off}$		77.61 95.15 99.54	
SC data	$V_{GE} \leq 15V, V_{ce}=900V$ $V_{CEmax}=V_{CES}-L_{sCE} \cdot di/dt$	$t_p \leq 10\mu s, T_{vj}=150^{\circ}C$	$I_{sc}$		2053	A
Thermal resistance, junction to case	per IGBT		$R_{thJC}$		0.07	K/W
Temperature under switching conditions			$T_{vj op}$	-40	150	$^{\circ}C$

## Diode, Inverter

### Maximum Ratings

Parameter	Conditions	Symbol	Value	Unit
Repetitive peak reverse voltage	$T_{vj}=25^{\circ}\text{C}$	$V_{RRM}$	1700	V
Continuous DC forward current		$I_F$	450	A
Repetitive peak forward current	$t_p=1\text{ms}$	$I_{FRM}$	900	A
$I^2t$ -value	$t_p=10\text{ms}$ , $\sin 180^{\circ}$ , $T_j=125^{\circ}\text{C}$	$I^2t$	20000	$\text{A}^2\text{s}$

### Characteristic Values

Parameter	Conditions	Symbol	Value			Unit
			Min.	Typ.	Max.	
Forward voltage	$I_F=450\text{A}$ , $V_{GE}=0\text{V}$ $T_{vj}=25^{\circ}\text{C}$ $I_F=450\text{A}$ , $V_{GE}=0\text{V}$ $T_{vj}=125^{\circ}\text{C}$ $I_F=450\text{A}$ , $V_{GE}=0\text{V}$ $T_{vj}=150^{\circ}\text{C}$	$V_F$		2.18 2.43 2.40	2.90	V
Peak reverse recovery current	$I_F=450\text{A}$ $T_{vj}=25^{\circ}\text{C}$ $-\text{di}_F/\text{dt}=2500\text{A}/\mu\text{s}$ ( $T_{vj}=150^{\circ}\text{C}$ ) $T_{vj}=125^{\circ}\text{C}$ $V_R=900\text{V}$ , $V_{GE}=-15\text{V}$ $T_{vj}=150^{\circ}\text{C}$	$I_{RM}$		182 211 220		A
Recovered charge	$I_F=450\text{A}$ $T_{vj}=25^{\circ}\text{C}$ $-\text{di}_F/\text{dt}=2500\text{A}/\mu\text{s}$ ( $T_{vj}=150^{\circ}\text{C}$ ) $T_{vj}=125^{\circ}\text{C}$ $V_R=900\text{V}$ , $V_{GE}=-15\text{V}$ $T_{vj}=150^{\circ}\text{C}$	$Q_r$		68.20 105.98 123.36		$\mu\text{C}$
Reverse recovered energy	$I_F=450\text{A}$ $T_{vj}=25^{\circ}\text{C}$ $-\text{di}_F/\text{dt}=2500\text{A}/\mu\text{s}$ ( $T_{vj}=150^{\circ}\text{C}$ ) $T_{vj}=125^{\circ}\text{C}$ $V_R=900\text{V}$ , $V_{GE}=-15\text{V}$ $T_{vj}=150^{\circ}\text{C}$	$E_{rec}$		37.03 57.75 68.13		mJ
Thermal resistance, junction to case	per diode	$R_{thJC}$			0.14	K/W
Temperature under switching conditions		$T_{vj\text{op}}$	-40		150	$^{\circ}\text{C}$

## NTC-Thermistor

### Characteristic Values

Parameter	Conditions	Symbol	Value			Unit
			Min.	Typ.	Max.	
Rated resistances	$T_c=25^{\circ}\text{C}$ , $\pm 5\%$	$R_{25}$		5.0		k $\Omega$
B-value	$\pm 2\%$	$B_{25/50}$		3375		K

## Module

Parameter	Conditions	Symbol	Value			Unit
Isolation test voltage	RMS, $f=50\text{Hz}$ , $t=1\text{min}$	$V_{\text{ISOL}}$	4000			V
Internal isolation			$\text{Al}_2\text{O}_3$			
Storage temperature		$T_{\text{stg}}$	-40		125	$^{\circ}\text{C}$
Mounting torque for modul mounting		M	3.0		6.0	Nm
Terminal connection torque		M	3.0		6.0	Nm
Weight		W		344		g

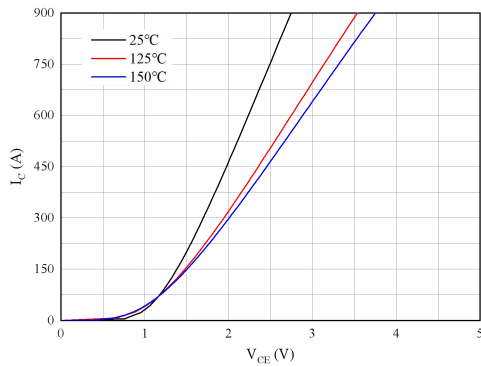

Fig 1. Typical output characteristics ( $V_{GE}=15V$ )

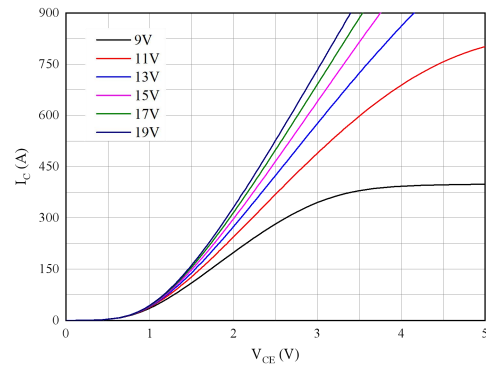

Fig 2. Typical output characteristics ( $T_{vj}=150^{\circ}C$ )

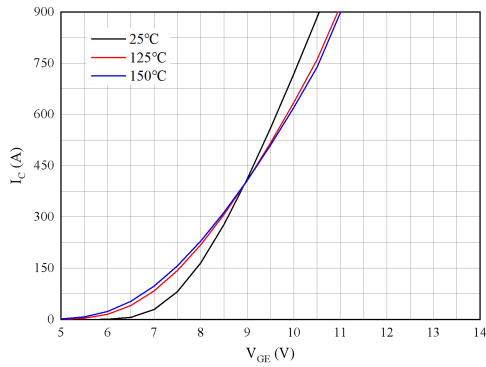

Fig 3. Typical transfer characteristic ( $V_{CE}=20V$ )

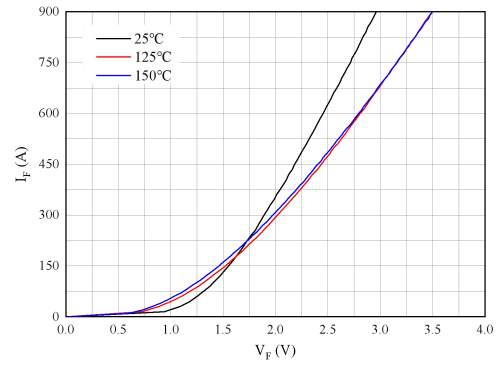

Fig 4. Forward characteristic of Diode

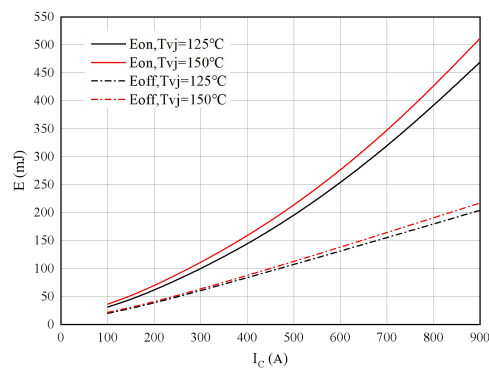

Fig 5. Switching losses of IGBT

$V_{GE}=\pm 15V, R_{Gon}=3.3\Omega, R_{Goff}=3.3\Omega, V_{CE}=900V$

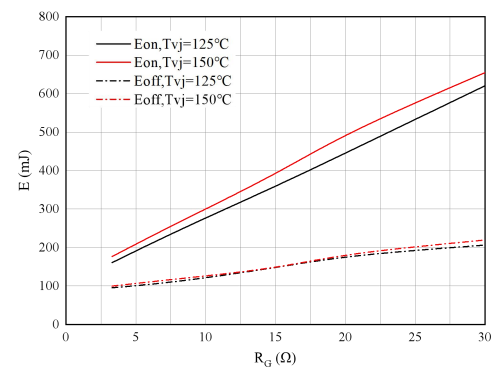

Fig 6. Switching losses of IGBT

$V_{GE}=\pm 15V, I_c=450A, V_{CE}=900V$

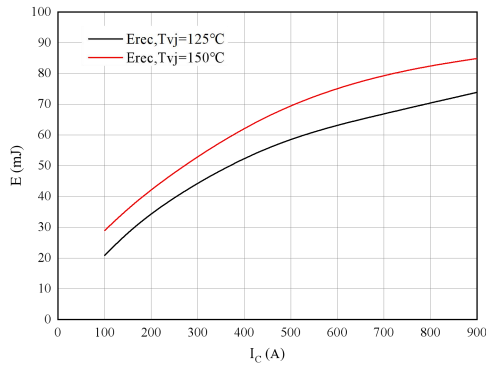

Fig 7. Switching losses of Diode

$R_{Gon}=3.3\Omega, V_{CE}=900V$

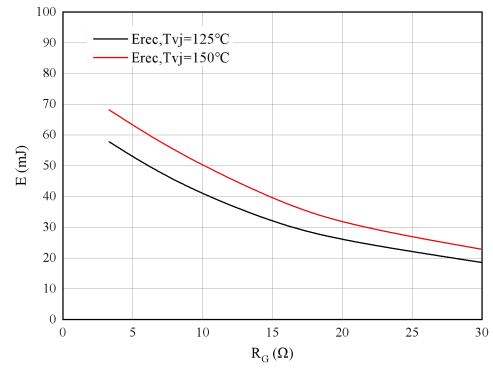

Fig 8. Switching losses of Diode

$I_F=450A, V_{CE}=900V$

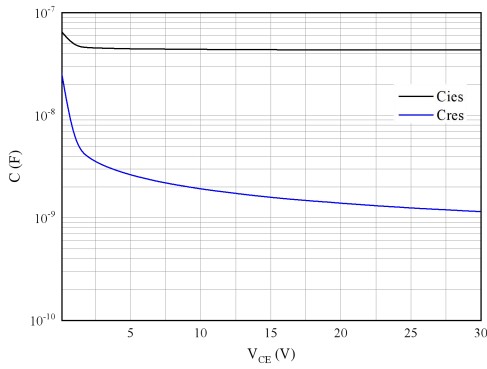

Fig 9. Capacitance characteristic

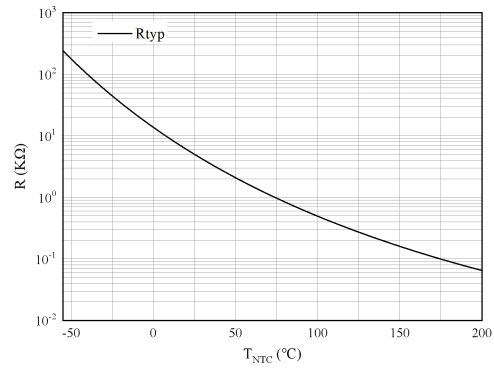

Fig 10. NTC-Themistor-temperature characteristic

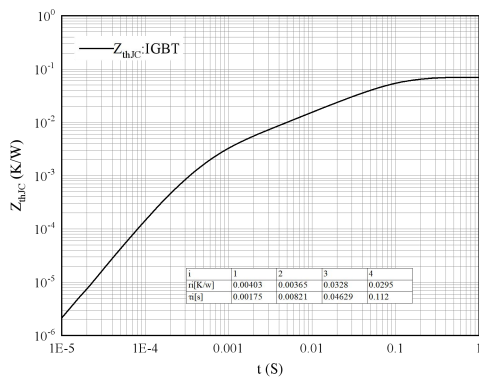

Fig 11. Transient thermal impedance IGBT, Inverter

$Z_{thJC}=f(t)$

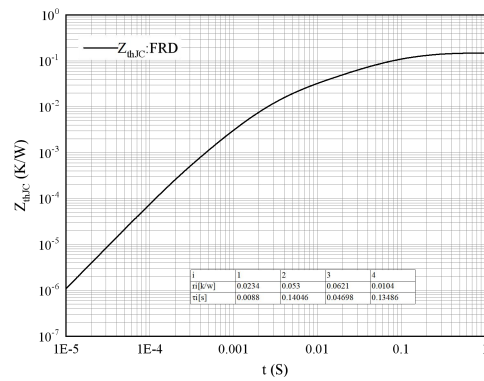
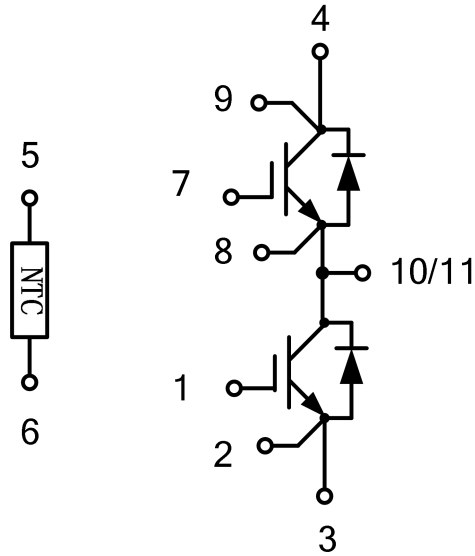

Fig 12. Transient thermal impedance FRD ,Inverter

$Z_{thJC}=f(t)$

**Circuit diagram**



**Package outlines**

