

Product Manual

EKWIN ELECTRONICS CO.,LTD

EK BT134

www.ekwin.net

Standard TRIACS
BT134 Serial
Main Features:

$I_{T(RMS)}$	V_{DRM}/V_{RRM}	V_{TM}
4 A	600V and 800 V	$\leq 1.7V$

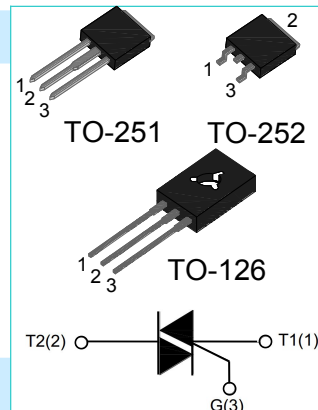
Description:

BT134 series triacs with low holding and latching current are especially recommended for use on middle and small resistance type power load.

Absolute Ratings(limiting values) :

Symbol	Parameter	Value	Unit	
T_{stg}	Storage junction temperature range	- 40 to + 150	$^{\circ}C$	
T_j	Operating junction temperature range	- 40 to + 125	$^{\circ}C$	
$I_{T(RMS)}$	RMS on-state current	TO-126 ($T_C=107^{\circ}C$)	4	A
		TO-251 / TO-252 ($T_C=110^{\circ}C$)		
I_{TSM}	Non repetitive surge peak on-state current (full cycle, $F=50Hz$)	25	A	
V_{DRM}	Repetitive peak off-state voltage($T_j =25^{\circ}C$)	600 and 800	V	
V_{RRM}	Repetitive peak reverse voltage($T_j =25^{\circ}C$)	600 and 800	V	
V_{DSM}	Non repetitive surge peak Off-state voltage	$V_{DRM} + 100$	V	
V_{RSM}	Non repetitive peak reverse voltage	$V_{RRM} + 100$	V	
I^2t	I^2t value for fusing $t_p = 10$ ms	3.1	A^2s	
dI/dt	Critical rate of rise of on-state current ($I_G =2 \times I_{GT}$)	50	$A/\mu s$	
I_{GM}	Peak gate current	2	A	

P_{G(AV)}	Average gate power dissipation	0.5	W
P_{GM}	Peak gate power	5	W

Electrical Characteristics (T_j=25°C unless otherwise specified) :

● **SNUBBERLESS(3 Quadrants)**

Symbol	Test Condition	Quadrant	Range	Value	Unit
				EW	
I_{GT}	V _D =12V R _L =33Ω	I-II-III	MAX	10	mA
V_{GT}		I-II-III	MAX	1.5	V
V_{GD}	V _D =V _{DRM} T _j =125°C R _L =3.3kΩ	I-II-III	MIN	0.2	V
I_L	I _G =1.2 I _{GT}	I-III	TYP	20	mA
		II		35	
I_H	IT= 100mA		MAX	20	mA
dV/dt	V _D =2/3V _{DRM} Gate Open T _j =125°C		MIN	50	V/μs
(dV/dt)_c	(dI/dt) _c =1.1A/ms T _j =125°C		MIN	5	V/μs

● **STANDARD(4 Quadrants)**

Symbol	Test Condition	Quadrant	Range	Value	Unit
				E	
I_{GT}	V _D =12V R _L =33Ω	I-II-III	MAX	10	mA
		IV	MAX	25	
V_{GT}		I-II-III-IV	MAX	1.5	V
V_{GD}	V _D =V _{DRM} T _j =125°C R _L =3.3kΩ	I-II-III-IV	MIN	0.2	V

I_L	I _G =1.2 I _{GT}	I-III-IV	TYP	20	mA
		II		35	
I_H	IT= 100mA		MAX	20	mA
dV/dt	V _D =2/3V _{DRM} Gate Open T _j =125°C		MIN	50	V/μs
(dV/dt)_c	(dI/dt) _c =1.1A/ms T _j =125°C		MIN	5	V/μs

STATIC CHARACTERISTICS

Symbol	Parameter			Value(MAX)	Unit
V_{TM}	I _{TM} = 5A tp= 380μs	T _j =25°C	MAX	1.7	V
I_{DRM} I_{RRM}	V _D =V _{DRM} , V _R =V _{RRM}	T _j =25°C	MAX	5	μ A
		T _j =125°C		1	mA

Thermal Resistances :

Symbol	Parameter		Value	Unit
R_{th(j-c)}	junction to case(AC)	TO-251/TO-252	3.7	°C/W
		TO-126	4.1	

Fig.1: Maximum power dissipation versus RMS on-state current

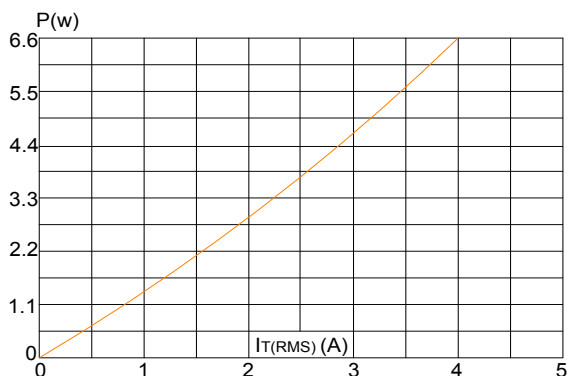

Fig.2 : RMS on-state current versus case temperature

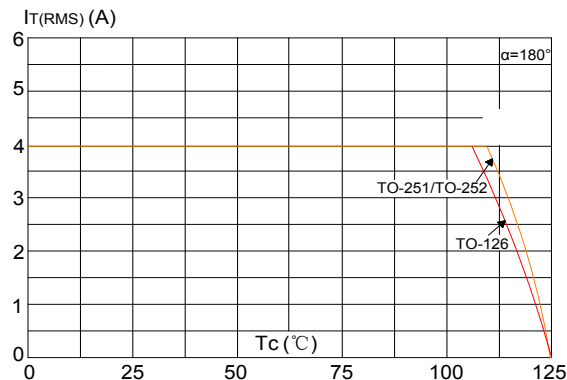

Fig.3 : Surge peak on-state current versus number of cycles

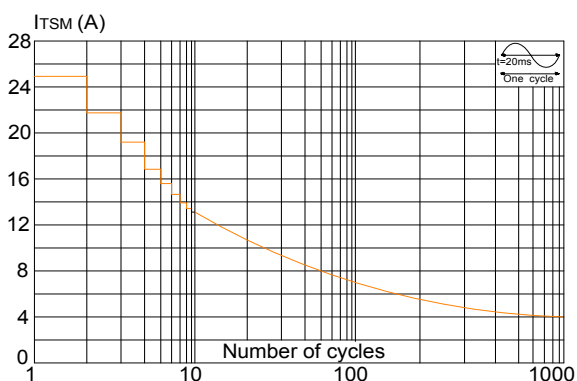

Fig.4 : On-state characteristics (maximum values)

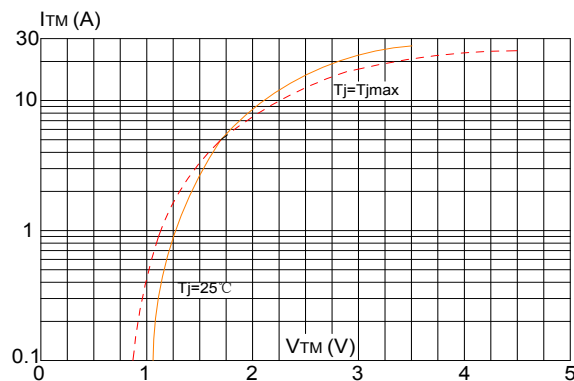

Fig.5: Non-repetitive surge peak on-state current for a sinusoidal pulse with width $t_p < 20\text{ms}$ and corresponding value of $I^2 t$ I - II - III: $dI/dt < 50\text{A}/\mu\text{s}$; IV: $dI/dt < 10\text{A}/\mu\text{s}$

Fig.6: Relative variations of gate trigger current versus junction temperature

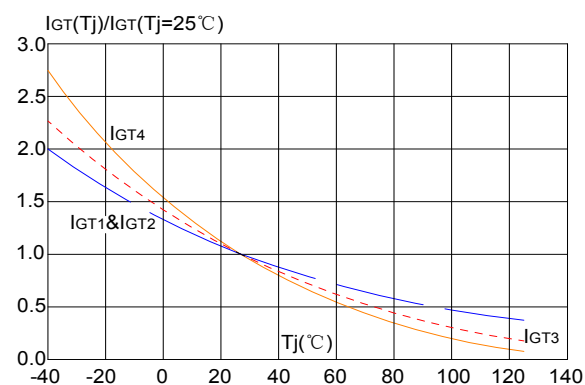
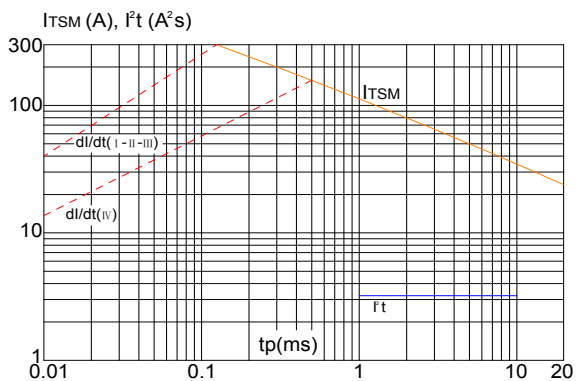

FIG.7: Relative variations of holding current Versus junction temperature

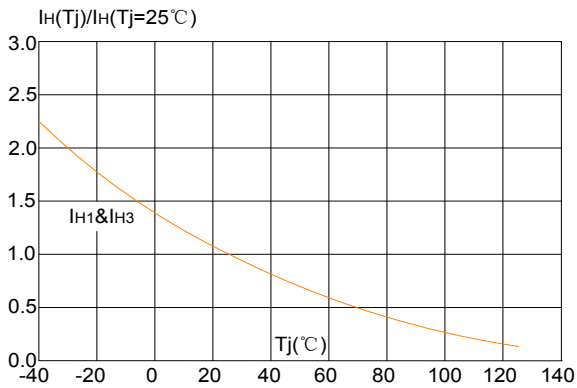
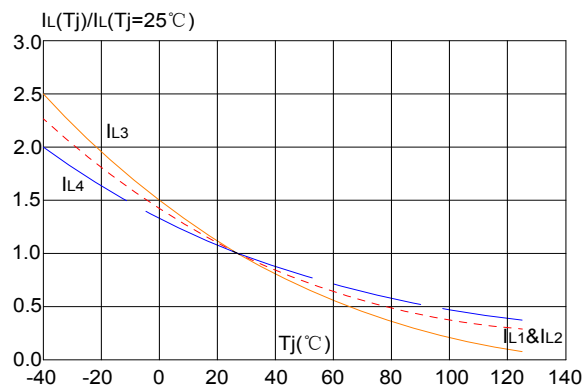

FIG.8: Relative variations of latching current versus junction temperature



Ordering Information:

<p>BT 134 - 600 E</p> <p>TRIAK SERIES</p> <p>$I_{T(RMS)}:4A$</p>	<p>E: IGT₁₋₃ ≤ 10mA STANDARD EW: IGT₁₋₃ ≤ 10mA SNUBBERLESS</p> <p>600: $V_{DRM}/V_{RRM} ≥ 600$ 800: $V_{DRM}/V_{RRM} ≥ 800$</p>
--	---

Package Mechanical Data :

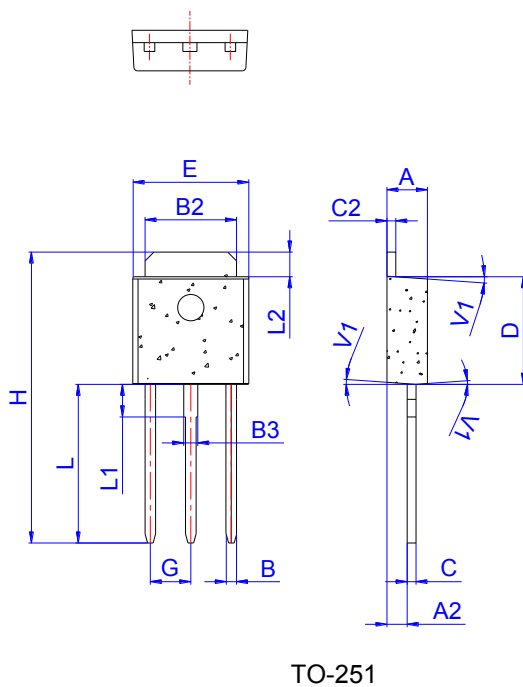

Ref.	Dimensions					
	Millimeters			Inches		
	Min.	Typ.	Max.	Min.	Typ.	Max.
A	2.20		2.40	0.086		0.095
A2	0.90		1.20	0.035		0.047
B	0.55		0.65	0.022		0.026
B2	5.10		5.40	0.200		0.213
B3	0.76		0.85	0.030		0.033
C	0.45		0.62	0.018		0.024
C2	0.48		0.62	0.019		0.024
D	6.00		6.20	0.236		0.244
E	6.40		6.70	0.252		0.264
G		2.30			0.091	
H	16.0		17.0	0.630		0.669
L	8.90		9.40	0.350		0.370
L1	1.80		1.90	0.071		0.075
L2	1.37		1.50	0.054		0.059
V1		4°			4°	

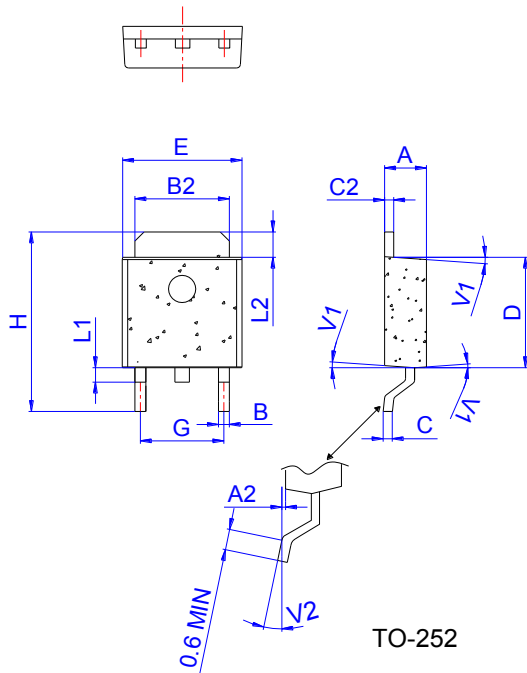

Ref.	Dimensions					
	Millimeters			Inches		
	Min.	Typ.	Max.	Min.	Typ.	Max.
A	2.20		2.40	0.086		0.095
A2	0.03		0.23	0.001		0.009
B	0.55		0.65	0.022		0.026
B2	5.10		5.40	0.200		0.213
C	0.45		0.62	0.018		0.024
C2	0.48		0.62	0.019		0.024
D	6.00		6.20	0.236		0.244
E	6.40		6.70	0.252		0.264
G	4.40		4.70	0.173		0.185
H	9.35		10.6	0.368		0.417
L1	1.30		1.70	0.051		0.067
L2	1.37		1.50	0.054		0.059
V1		4°			4°	
V2	0°		8°	0°		8°

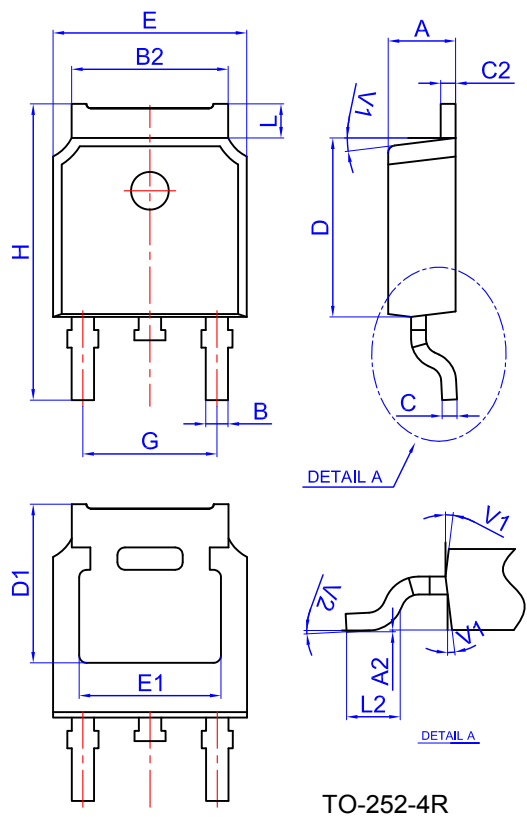

Ref.	Dimensions					
	Millimeters			Inches		
	Min.	Typ.	Max.	Min.	Typ.	Max.
A	2.10		2.50	0.083		0.098
A2	0		0.10	0		0.004
B	0.66		0.86	0.026		0.034
B2	5.18		5.48	0.202		0.216
C	0.40		0.60	0.016		0.024
C2	0.44		0.58	0.017		0.023
D	5.90		6.30	0.232		0.248
D1	5.30REF			0.209REF		
E	6.40		6.80	0.252		0.268
E1	4.63			0.182		
G	4.47		4.67	0.176		0.184
H	9.50		10.70	0.374		0.421
L	1.09		1.21	0.043		0.048
L2	1.35		1.65	0.053		0.065
V1		7°			7°	
V2	0°		6°	0°		6°

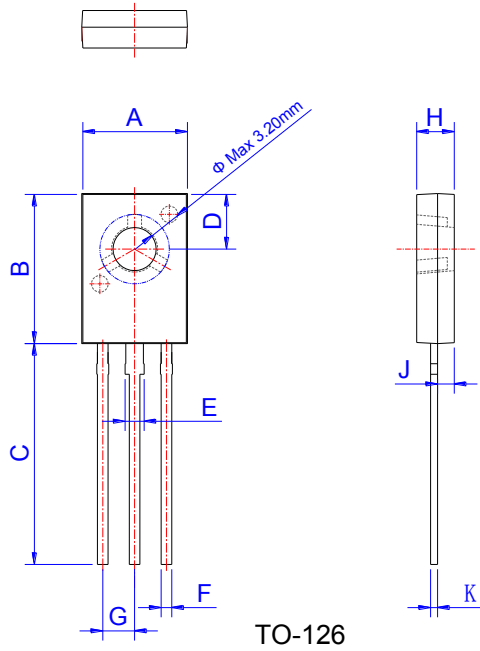

Ref.	Dimensions					
	Millimeters			Inches		
	Min.	Typ.	Max.	Min.	Typ.	Max.
A	7.40		8.00	0.291		0.315
B	10.6		11.2	0.417		0.441
C	12.3		16.3	0.484		0.642
D	3.90		4.10	0.154		0.161
E	1.17		1.47	0.046		0.058
F	0.66		0.86	0.026		0.034
G		2.29			0.090	
H	2.50		2.90	0.098		0.114
J	1.10		1.50	0.043		0.059
K	0.45		0.60	0.018		0.024

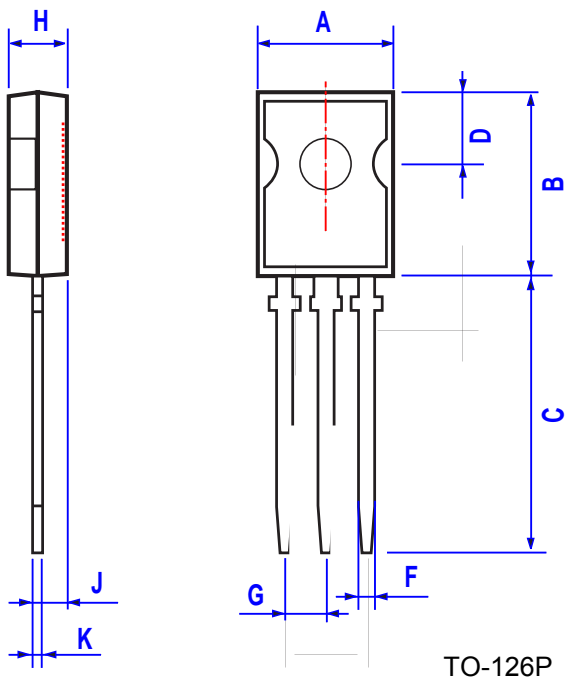

Ref.	Dimensions					
	Millimeters			Inches		
	Min.	Typ.	Max.	Min.	Typ.	Max.
A	7.40		7.80	0.291		0.307
B	10.5		10.8	0.413		0.444
C	12.4		16.0	0.606		0.629
D		3.80			0.150	0.161
F	0.70		0.90	0.028		0.030
G		2.2			0.087	
H	2.40		2.70	0.094		0.106
J	1.00		1.30	0.039		0.050
K	0.49		0.75	0.019		0.030