

Product Manual

EKWIN ELECTRONICS CO.,LTD

EK BT139

www.ekwin.net

 Standard TRIACS

BT139 Serial

Main Features:

$I_{T(RMS)}$	V_{DRM}/V_{RRM}	V_{TM}
16 A	600V and 800V	$\leq 1.6V$

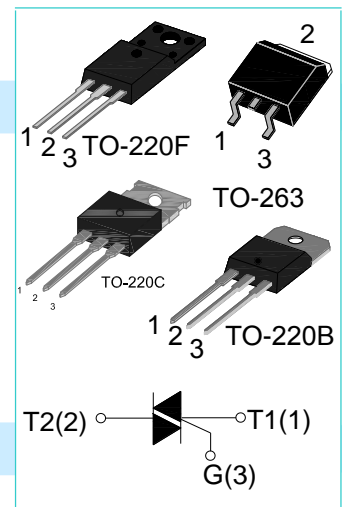

Description:

High current density due to mesa technology;Glass passivtion.BT139 series TRIACS is suitable for general purpose AC switching.they can be used as an ON/OFF Function in applications such as static relays,heating regulation,induction motor stating circuits..or for phase control operation light dimmers,motor speed controllers.

Absolute Ratings(limiting values) :

Symbol	Parameter	Value	Unit	
T_{stg}	Storage junction temperature range	- 40 to + 150	$^{\circ}C$	
T_j	Operating junction temperature range	- 40 to + 125	$^{\circ}C$	
$I_{T(RMS)}$	RMS on-state current	TO-220F (TC=85 $^{\circ}C$)	16	A
		TO-220B/C (TC=100 $^{\circ}C$)		
		TO-263 (TC=110 $^{\circ}C$)		
I_{TSM}	Non repetitive surge peak on-state current (full cycle, F=50Hz)	140	A	
V_{DRM}	Repetitive peak off-state voltage($T_j = 25^{\circ}C$)	600 and 800	V	
V_{RRM}	Repetitive peak reverse voltage($T_j = 25^{\circ}C$)	600 and 800	V	
V_{DSM}	Non repetitive surge peak Off-state voltage	$V_{DRM} + 100$	V	
V_{RSM}	Non repetitive peak reverse voltage	$V_{RRM} + 100$	V	

I²t	I ² t value for fusing t _p = 10 ms	98	A ² s
dI/dt	Critical rate of rise of on-state current (I _G = 2 × I _{GT})	50	A/μs
I_{GM}	Peak gate current	2	A
P_{G(AV)}	Average gate power dissipation	0.5	W
P_{GM}	Peak gate power	5	W

● SNUBBERLESS(3 Quadrants)

Symbol	Test Condition	Quadrant	Range	Value	Unit
				EW	
I_{GT}	V _D =12V R _L =33Ω	I-II-III	MAX	10	mA
V_{GT}		I-II-III	MAX	1.5	
V_{GD}	V _D =V _{DRM} T _j =125°C R _L =3.3kΩ	I-II-III	MIN	0.2	V
I_L	I _G =1.2 I _{GT}	I-III	TYP	30	mA
		II		40	
I_H	IT= 100mA		MAX	25	mA
dV/dt	V _D =2/3V _{DRM} Gate Open T _j =125°C		MIN	10	V/μs

● STANDARD(4 Quadrants)

Symbol	Test Condition	Quadrant	Range	Value	Unit
				E	
I_{GT}	V _D =12V R _L =33Ω	I-II-III	MAX	10	mA
		IV	MAX	25	
V_{GT}		I-II-III-IV	MAX	1.5	V
V_{GD}	V _D =V _{DRM} T _j =125°C R _L =3.3kΩ	I-II-III-IV	MIN	0.2	V

I_L	I _G =1.2 I _{GT}	I-III-IV	TYP	30	mA
		II		40	
I_H	I _T = 100mA		MAX	25	mA
dV/dt	V _D =2/3V _{DRM} Gate Open T _j =125°C		MIN	10	V/μs

STATIC CHARACTERISTICS

Symbol	Parameter			Value(MAX)	Unit
V_{TM}	I _{TM} = 20A tp= 380μs	T _j =25°C	MAX	1.6	V
I_{DRM} I_{RRM}	V _D =V _{DRM} ,V _R =V _{RRM}	T _j =25°C	MAX	5	μA
		T _j =125°C		1	mA

Thermal Resistances :

Symbol	Parameter		Value	Unit
R_{th(j-c)}	junction to case(AC)	TO-220F (TC=85°C)	3.0	°C/W
		TO-220B/C (TC=100°C)		
		TO-263 (TC=110°C)		

Ordering Information:

<p>BT 139 - 600 E</p> <p>TRIAC SERIES</p> <p>I_{T(RMS)}:16A</p>	<p>E: IGT₁₋₃ ≤10mA STANDARD</p> <p>EW:IGT₁₋₃ ≤10mA SNUBBERLESS</p> <p>600:V_{DRM}/V_{RRM} ≥600</p> <p>800:V_{DRM}/V_{RRM} ≥800</p>
--	--

FIG.1 Maximum power dissipation versus RMS on-state current

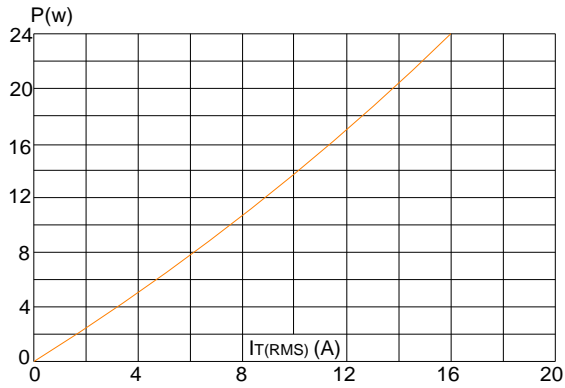

FIG.2: RMS on-state current versus case temperature

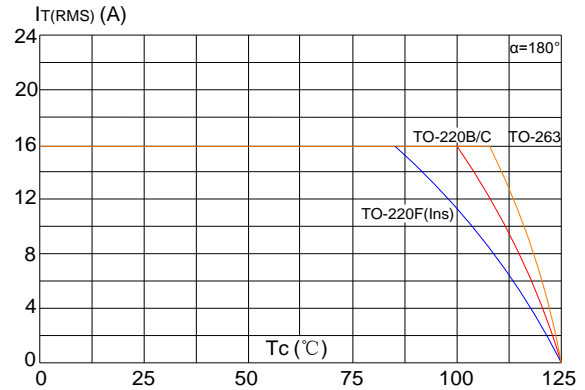

FIG.3: Surge peak on-state current versus number of cycles

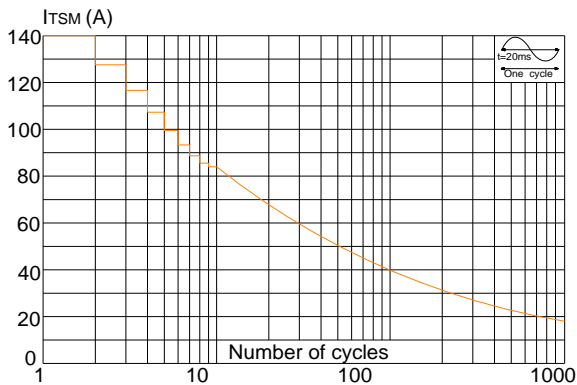

FIG.4: On-state characteristics (maximum values)

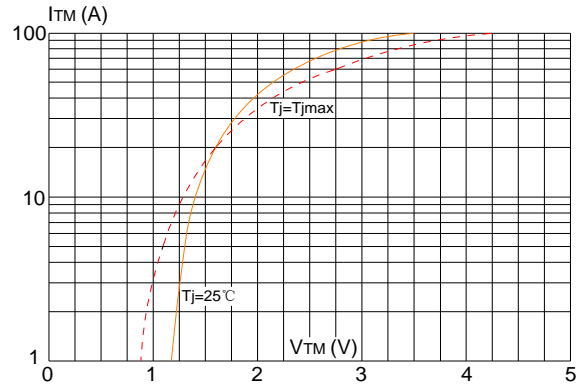

FIG.5: Non-repetitive surge peak on-state current for a sinusoidal pulse with width $t_p < 20\text{ms}$, and corresponding value of I^2t ($di/dt < 50\text{A}/\mu\text{s}$)

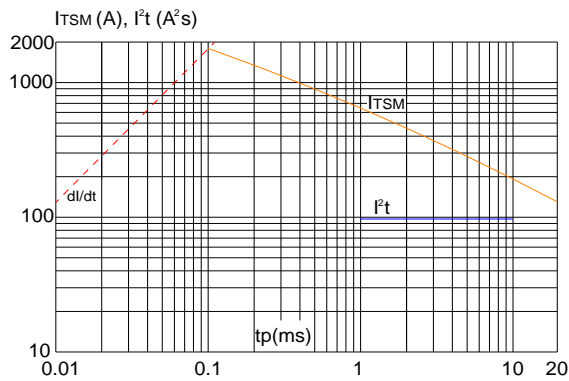

FIG.6: Relative variations of gate trigger current versus junction temperature

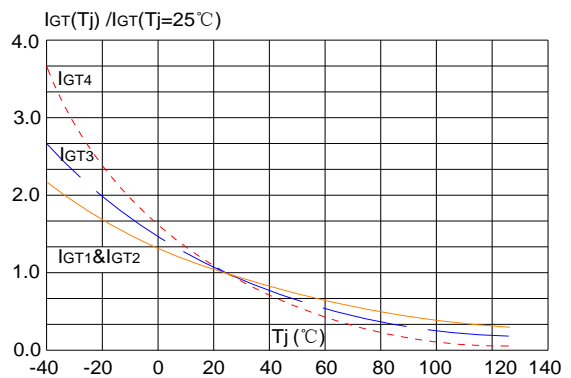

FIG.7: Relative variations of holding current versus junction temperature

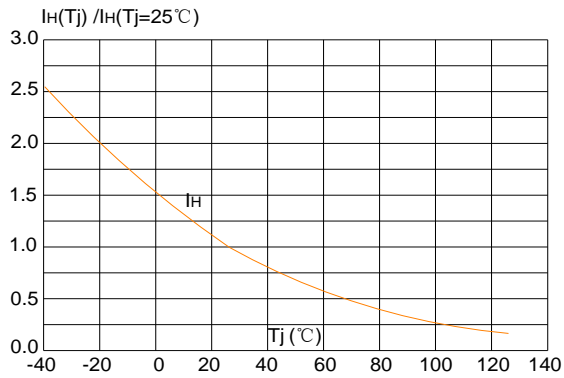
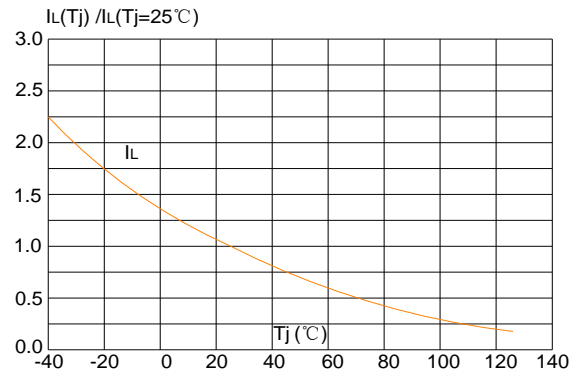
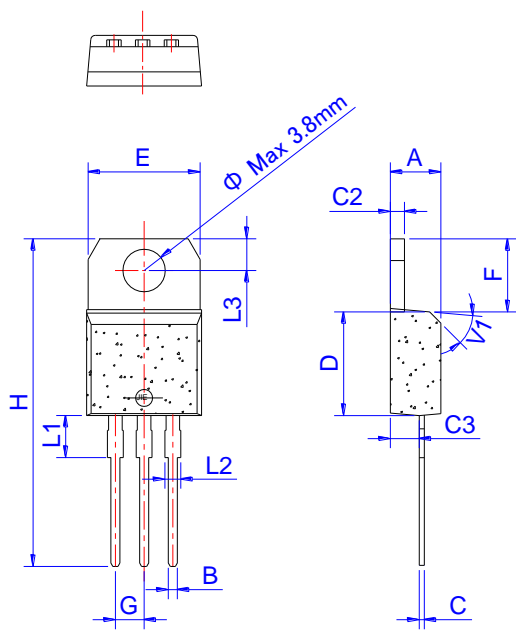

FIG.8: Relative variations of latching current versus junction temperature



Package Mechanical Data :



TO-220B Non-Ins

Ref.	Dimensions					
	Millimeters			Inches		
	Min.	Typ.	Max.	Min.	Typ.	Max.
A	4.40		4.60	0.173		0.181
B	0.61		0.88	0.024		0.035
C	0.46		0.70	0.018		0.028
C2	1.21		1.32	0.048		0.052
C3	2.40		2.72	0.094		0.107
D	8.60		9.70	0.339		0.382
E	9.60		10.4	0.378		0.409
F	6.20		6.60	0.244		0.260
G		2.54			0.1	
H	28.0		29.8	1.102		1.173
L1		3.75			0.148	
L2	1.14		1.70	0.045		0.067
L3	2.65		2.95	0.104		0.116
V1		45°			45°	

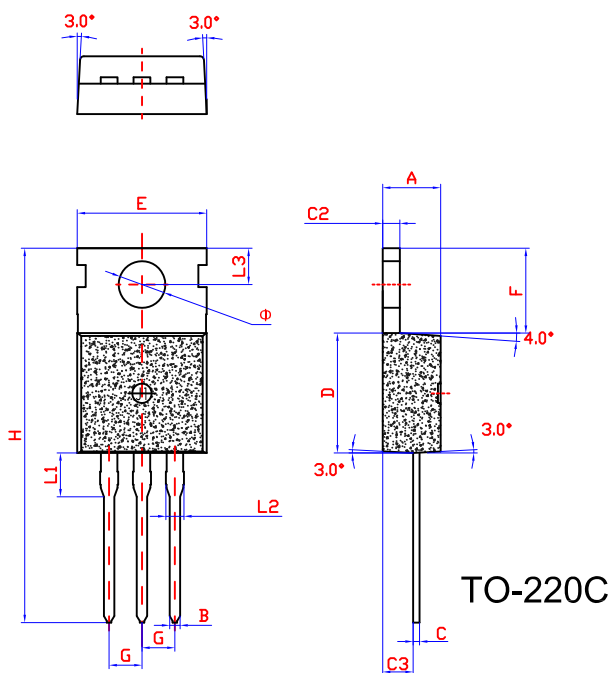

TO-220C

Ref.	Dimensions					
	Millimeters			Inches		
	Min.	Typ.	Max.	Min.	Typ.	Max.
A	4.4		4.6	0.173		1.181
B	0.7		0.9	0.027		0.035
C	0.45		0.6	0.018		0.024
C2	1.23		1.32	0.048		0.052
C3	2.2		2.6	0.086		0.102
D	8.9		9.9	0.350		0.390
E	9.9		10.3	0.390		0.406
F	6.3		6.9	0.248		0.272
G		2.54			0.1	
H	28.0		29.8	11.0		11.7
L1		3.2			0.126	
L2	1.14		1.7	0.045		0.067
L3	2.65		2.95	0.104		0.116
Φ		3.6			0.142	

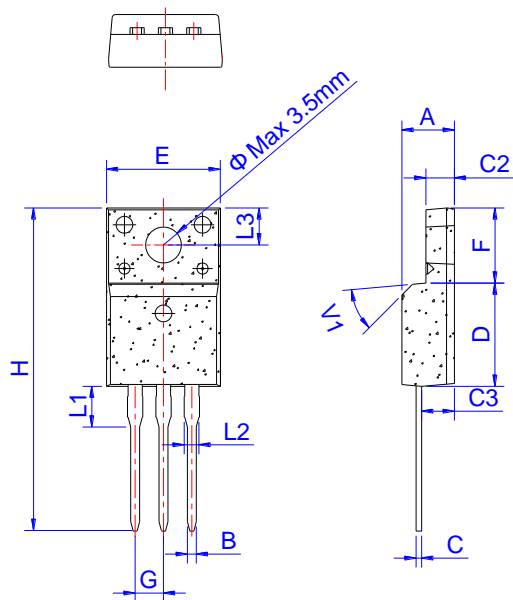

TO-220F Ins

Ref.	Dimensions					
	Millimeters			Inches		
	Min.	Typ.	Max.	Min.	Typ.	Max.
A	4.40		4.80	0.173		0.189
B	0.74	0.80	0.83	0.029	0.031	0.033
C	0.48		0.75	0.019		0.030
C2	2.40		2.70	0.094		0.106
C3	2.60		3.00	0.102		0.118
D	8.80		9.30	0.346		0.366
E	9.70		10.3	0.382		0.406
F	6.40		7.00	0.252		0.276
G		2.54			0.1	
H	28.0		29.8	1.102		1.173
L1		3.63			0.143	
L2	1.14		1.70	0.045		0.067
L3		3.30			0.130	
V1		45°			45°	

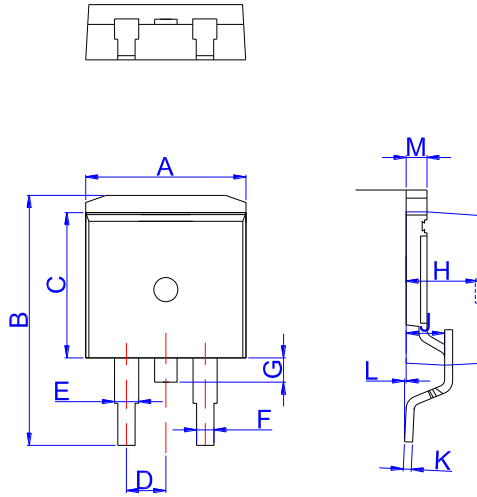

TO-263

Ref.	Dimensions					
	Millimeters			Inches		
	Min.	Typ.	Max.	Min.	Typ.	Max.
A	9.90		10.20	0.390		0.402
B	14.70		15.80	0.579		0.622
C	9.4		9.6	0.37		0.378
D		2.54			0.100	
E	1.20		1.40	0.047		0.055
F	0.75		0.85	0.029		0.033
G			1.75			0.069
H	4.40		4.70	0.173		0.185
J	2.30		2.70	0.091		0.106
K	0.38		0.55	0.015		0.022
L	0	0.10	0.25	0	0.004	0.010
M	1.25		1.35	0.049		0.053