

# Product Manual

EKWIN ELECTRONICS CO.,LTD

**EK BTA16**

[www.ekwin.net](http://www.ekwin.net)

**Standard TRIACS**
**BTA16 Serial**
**Main Features:**

$I_{T(RMS)}$	$V_{DRM}/V_{RRM}$	$V_{TM}$
16 A	600V 800V	$\leq 1.55$ V

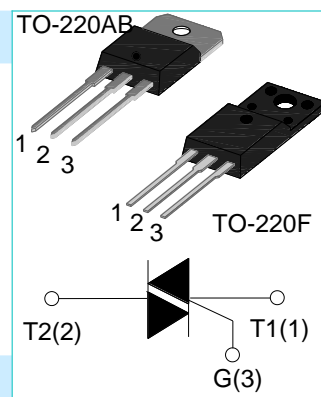
**Description:**

High current density due to double mesa technology; Glass Passivation. BTA16 series TRIACS is suitable for general purpose AC switching. They can be used as an ON/OFF Function in applications such as static relays, heating regulation, induction motor starting circuits, or for phase control operation light dimmers, motor speed controllers.

**Absolute Ratings (limiting values) :**

Symbol	Parameter	Value	Unit	
$T_{stg}$	Storage junction temperature range	- 40 to + 150	$^{\circ}C$	
$T_j$	Operating junction temperature range	- 40 to + 125	$^{\circ}C$	
$I_{T(RMS)}$	RMS on-state current	TO-220F (TC=90 $^{\circ}C$ )	16	A
		TO-220AB (TC=86 $^{\circ}C$ )		
$I_{TSM}$	Non repetitive surge peak on-state current (tp=10ms)	160	A	
$V_{DRM}$	Repetitive peak off-state voltage (Tj =25 $^{\circ}C$ )	600/800	V	
$V_{RRM}$	Repetitive peak reverse voltage (Tj =25 $^{\circ}C$ )	600/800	V	
$V_{DSM}$	Non repetitive surge peak Off-state voltage	$V_{DRM} + 100$	V	
$V_{RSM}$	Non repetitive peak reverse voltage	$V_{RRM} + 100$	V	
$I^2t$	$I^2t$ value for fusing tp = 10 ms	128	A <sup>2</sup> s	
$dI/dt$	Critical rate of rise of on-state current ( $I_G = 2 \times I_{GT}$ )	50	A/ $\mu$ s	

<b>I<sub>GM</sub></b>	Peak gate current	4	A
<b>P<sub>G(AV)</sub></b>	Average gate power dissipation	1	W
<b>P<sub>GM</sub></b>	Peak gate power	5	W

### Electrical Characteristics : (T<sub>j</sub>=25°C unless otherwise specified)

- 3 Quadrants (V<sub>DRM</sub> /V<sub>RRM</sub>: 600/800V)

Symbol	Test Condition	Quadrant	Range	Value				Unit
				B	C	S	T	
<b>I<sub>GT</sub></b>	V <sub>D</sub> =12V R <sub>L</sub> =33Ω	I-II-III	MAX	50	35	10	5	mA
<b>V<sub>GT</sub></b>		I-II-III	MAX	1.5				V
<b>V<sub>GD</sub></b>	V <sub>D</sub> =V <sub>DRM</sub> R <sub>L</sub> =3.3kΩ T <sub>j</sub> =125°C	I-II-III	MIN	0.2				V
<b>I<sub>L</sub></b>	I <sub>G</sub> =1.2 I <sub>GT</sub>	I-III	MAX	70	50	25	10	mA
		II		80	60	30	15	
<b>I<sub>H</sub></b>	I <sub>TM</sub> = 100mA		MAX	60	40	15	10	mA
<b>dV/dt</b>	V <sub>D</sub> =2/3V <sub>DRM</sub> Gate Open T <sub>j</sub> =125°C		MIN	1000	500	40	20	V/μs
<b>(dV/dt)<sub>c</sub></b>	(dI/dt) <sub>c</sub> =1.7A/ms T <sub>j</sub> =125°C		MIN	14	8.5	6.0	5.0	V/μs

- 3 Quadrants (V<sub>DRM</sub> /V<sub>RRM</sub>: 1200V)

Symbol	Test Condition	Quadrant	Range	Value	Unit
<b>I<sub>GT</sub></b>	V <sub>D</sub> =12V R <sub>L</sub> =33Ω	I-II-III	MAX	50	mA
<b>V<sub>GT</sub></b>		I-II-III	MAX	1.5	V

<b>V<sub>GD</sub></b>	V <sub>D</sub> =V <sub>DRM</sub> R <sub>L</sub> =3.3kΩ T <sub>j</sub> =125°C	I-II-III	MIN	0.25	V
<b>I<sub>L</sub></b>	I <sub>G</sub> =1.2 I <sub>GT</sub>	I-III	MAX	70	mA
		II		80	
<b>I<sub>H</sub></b>	I <sub>TM</sub> = 100mA		MAX	60	mA
<b>dV/dt</b>	V <sub>D</sub> =2/3V <sub>DRM</sub> Gate Open T <sub>j</sub> =125°C		MIN	1500	V/μs
<b>(dV/dt)<sub>c</sub></b>	(dI/dt) <sub>c</sub> =1.7A/ms T <sub>j</sub> =125°C		MIN	14	V/μs

### Static Characteristics

Symbol	Parameter		Value(MAX)		Unit
			600V	800V	
<b>V<sub>TM</sub></b>	I <sub>TM</sub> =22.5A tp= 380μs	T <sub>j</sub> =25°C	1.55		V
<b>I<sub>DRM</sub></b> <b>I<sub>RRM</sub></b>	V <sub>D</sub> =V <sub>DRM</sub> , V <sub>R</sub> =V <sub>RRM</sub>	T <sub>j</sub> =25°C	5	5	μA
		T <sub>j</sub> =125°C	2	2	mA

### Thermal Resistances :

Symbol	Parameter		Value	Unit	
<b>R<sub>th(j-c)</sub></b>	Junction to case for AC		TO-220AB	3.9	°C/W
			TO-220F	3.3	

Fig.1: Maximum power dissipation versus RMS on-state current

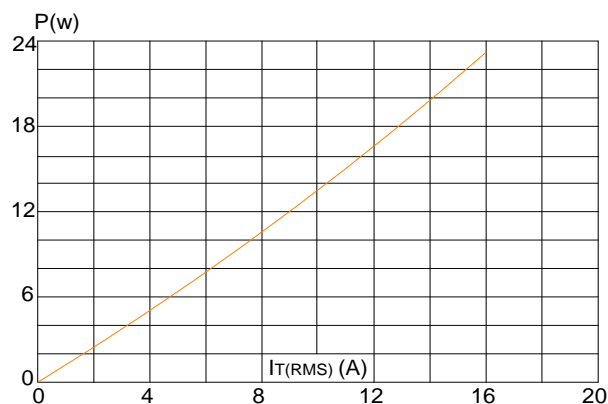

Fig.2 : RMS on-state current versus case temperature

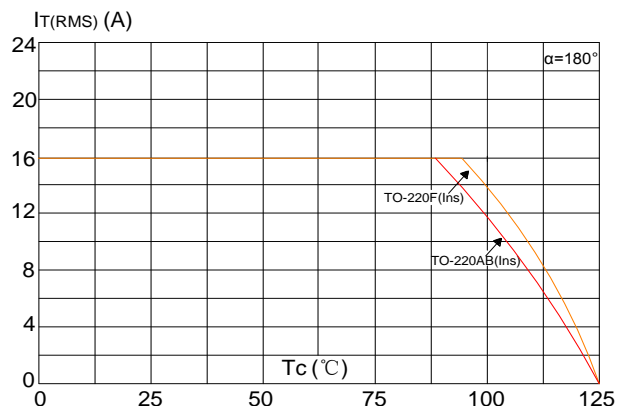

Fig.3 : Surge peak on-state current versus number of cycles

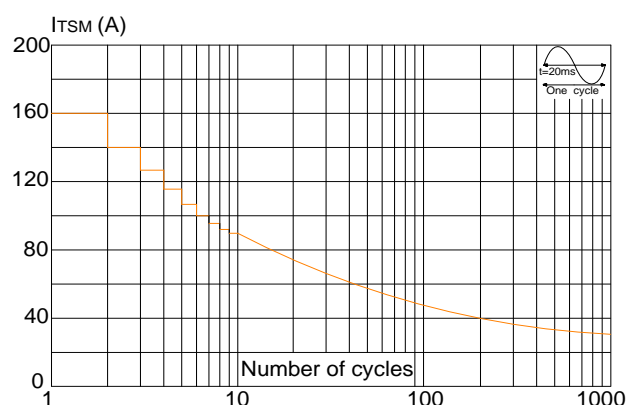

Fig.4 : On-state characteristics (maximum values)

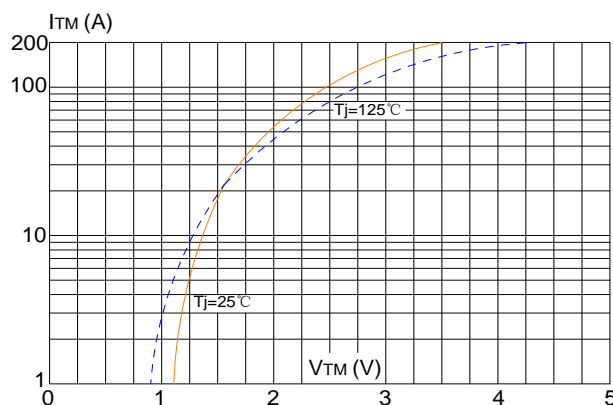

Fig.5 : Non-repetitive surge peak on-state current for a sinusoidal pulse with width  $t_p < 20\text{ms}$  and corresponding value of  $I t$  ( $dI/dt < 50\text{A}/\mu\text{s}$ )

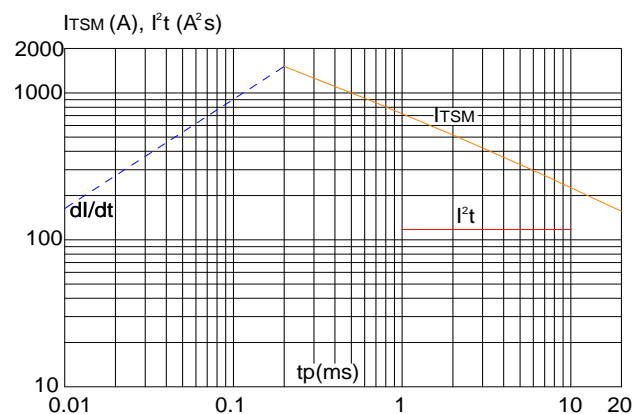
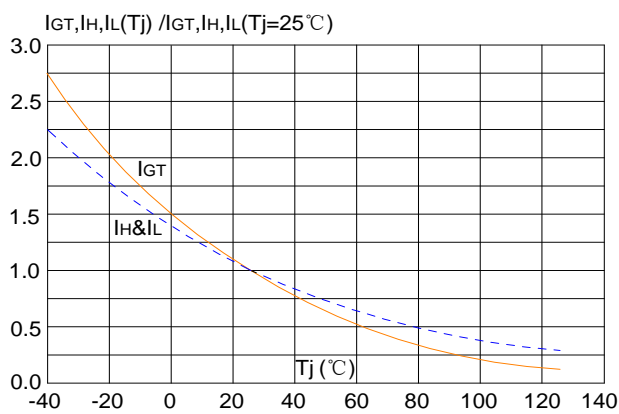
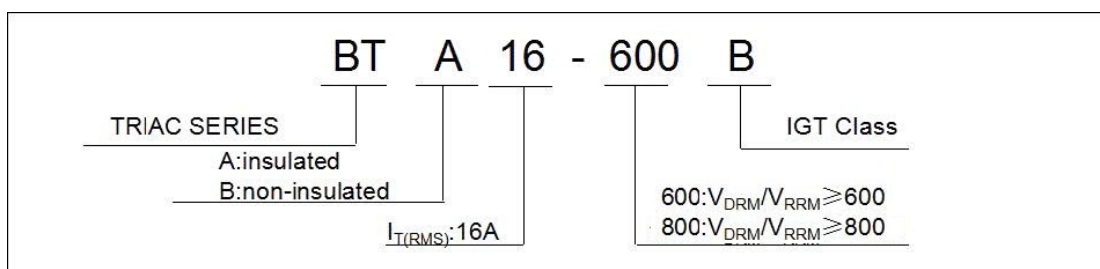

Fig.6: Relative variations of gate trigger current, holding current and latching current versus junction temperature



## Ordering Information:



## Package Mechanical Data :

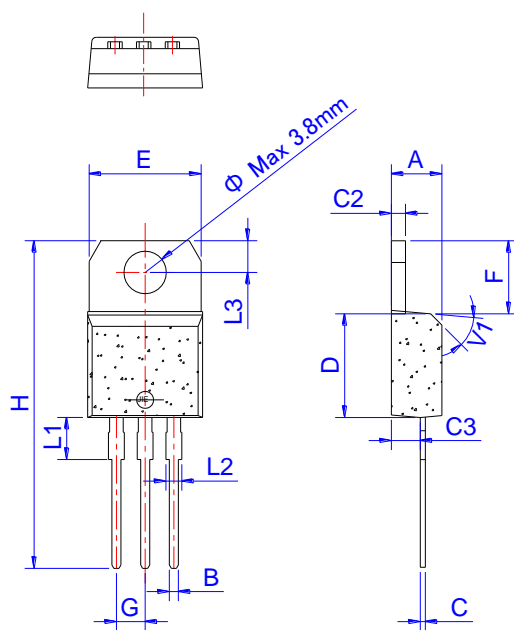

Ref.	Dimensions					
	Millimeters			Inches		
	Min.	Typ.	Max.	Min.	Typ.	Max.
A	4.40		4.60	0.173		0.181
B	0.61		0.88	0.024		0.035
C	0.46		0.70	0.018		0.028
C2	1.21		1.32	0.048		0.052
C3	2.40		2.72	0.094		0.107
D	8.60		9.70	0.339		0.382
E	9.60		10.4	0.378		0.409
F	6.20		6.60	0.244		0.260
G		2.54			0.1	
H	28.0		29.8	1.102		1.173
L1		3.75			0.148	
L2	1.14		1.70	0.045		0.067
L3	2.65		2.95	0.104		0.116
V1		45°			45°	

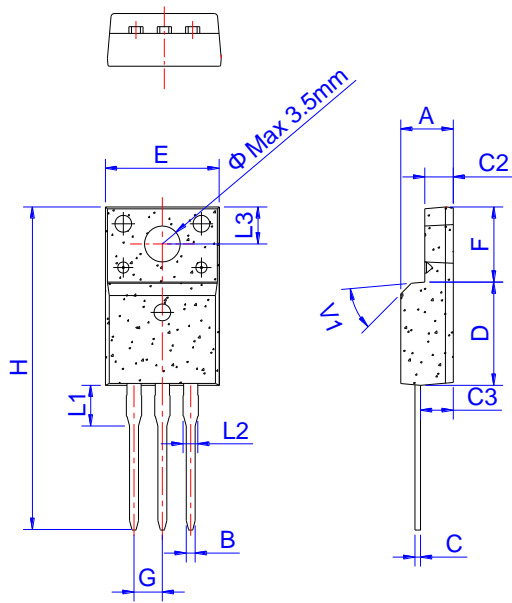

TO-220F Ins

Ref.	Dimensions					
	Millimeters			Inches		
	Min.	Typ.	Max.	Min.	Typ.	Max.
A	4.40		4.80	0.173		0.189
B	0.74	0.80	0.83	0.029	0.031	0.033
C	0.48		0.75	0.019		0.030
C2	2.40		2.70	0.094		0.106
C3	2.60		3.00	0.102		0.118
D	8.80		9.30	0.346		0.366
E	9.70		10.3	0.382		0.406
F	6.40		7.00	0.252		0.276
G		2.54			0.1	
H	28.0		29.8	1.102		1.173
L1		3.63			0.143	
L2	1.14		1.70	0.045		0.067
L3		3.30			0.130	
V1		45°			45°	