

Product Manual

EKWIN ELECTRONICS CO.,LTD

EK BTA24

www.ekwin.net

Standard TRIACS
BTA24 Serial
Main Features:

$I_{T(RMS)}$	V_{DRM}/V_{RRM}	V_{TM}
25A	600V 800V 1200 V	$\leq 1.5 V$

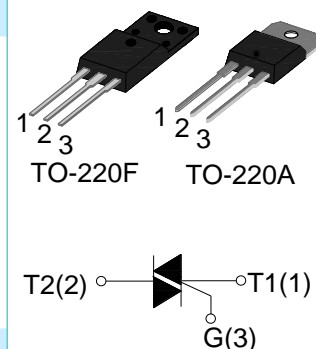
Description:

High current density due to double mesa technology; Glass Passivation. BTA24 series TRIACS is suitable for general purpose AC switching. They can be used as an ON/OFF function in applications such as static relays, heating regulation, induction motor starting circuits, or for phase control operation light dimmers, motor speed controllers.

Absolute Ratings (limiting values) :

Symbol	Parameter	Value	Unit	
T_{stg}	Storage junction temperature range	- 40 to + 150	$^{\circ}C$	
T_j	Operating junction temperature range	- 40 to + 125	$^{\circ}C$	
$I_{T(RMS)}$	RMS on-state current	TO-220F(Ins) (TC=75 $^{\circ}C$)	25	A
		TO-220A(Ins) (TC=70 $^{\circ}C$)		
I_{TSM}	Non repetitive surge peak on-state current (full cycle, F=50Hz)	250	A	
V_{DRM}	Repetitive peak off-state voltage (T _j =25 $^{\circ}C$)	600/800/1200	V	
V_{RRM}	Repetitive peak reverse voltage (T _j =25 $^{\circ}C$)	600/800/1200	V	
V_{DSM}	Non repetitive surge peak Off-state voltage	$V_{DRM} + 100$	V	
V_{RSM}	Non repetitive peak reverse voltage	$V_{RRM} + 100$	V	
I^2t	I ² t value for fusing t _p = 10 ms	340	A ² s	
dI/dt	Critical rate of rise of on-state current (I _G =2 × I _{GT})	50	A/ μ s	

I_{GM}	Peak gate current	4	A
P_{G(AV)}	Average gate power dissipation	1	W
P_{GM}	Peak gate power	10	W

Electrical Characteristics : (T_j=25°C unless otherwise specified)

Symbol	Test Condition	Quadrant	Range	V _{DRM} /V _{RRM} : 600/800V		V _{DRM} /V _{RRM} : 1200		Unit
				B	C	B	C	
I_{GT}	V _D =12V R _L =33Ω	I-II-III	MAX	50	35	50	35	mA
V_{GT}		I-II-III	MAX	1.3		1.5		V
V_{GD}	V _D =V _{DRM} R _L =3.3kΩ T _j =125°C	I-II-III	MIN	0.2				V
I_L	I _G =1.2 I _{GT}	I-III	MAX	80	70	90	70	mA
		II		100	80	100	80	
I_H	I _{TM} = 100mA		MAX	75	50	80	60	mA
dV/dt	V _D =2/3V _{DRM} Gate Open T _j =125°C		MIN	1000	500	1500	1000	V/μs
(dV/dt)_c	(dI/dt) _c =8.8A/ms T _j =125°C		MIN	22	13	30	20	V/μs

Static Characteristics

Symbol	Parameter		Value(MAX)	Unit
V_{TM}	I _{TM} =35A tp= 380μs	T _j =25°C	1.5	V
I_{DRM} I_{RRM}	V _D =V _{DRM} , V _R =V _{RRM}	T _j =25°C	5	μ A
		T _j =125°C	3	mA

Thermal Resistances :

Symbol	Parameter		Value	Unit
R_{th(j-c)}	Junction to case for AC	TO-220A(Ins)	1.75	°C/W
		TO-220F(Ins)	1.7	

Fig.1: Maximum power dissipation versus RMS on-state current

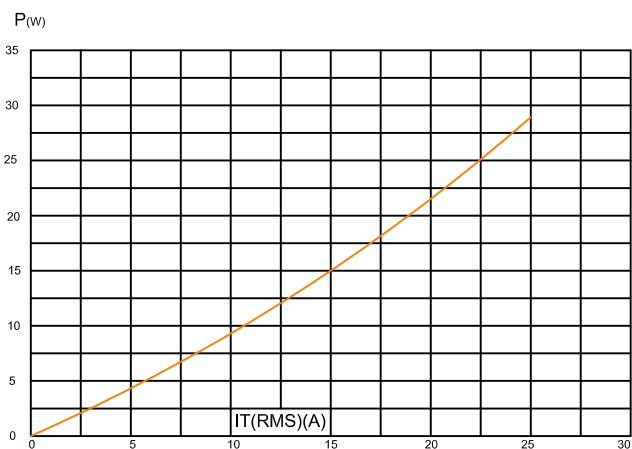

Fig.2 : RMS on-state current versus case temperature

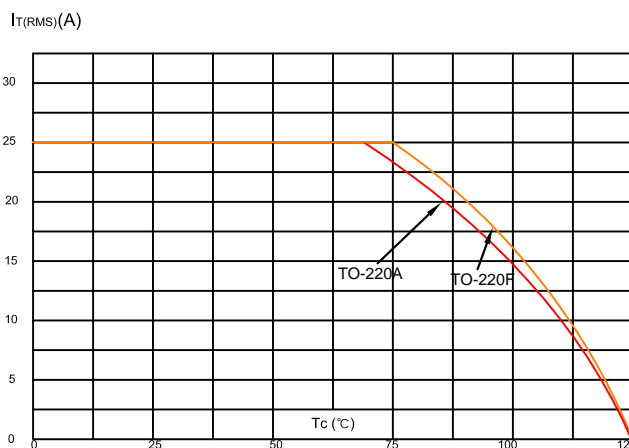

Fig.3 : Surge peak on-state current versus number of cycles

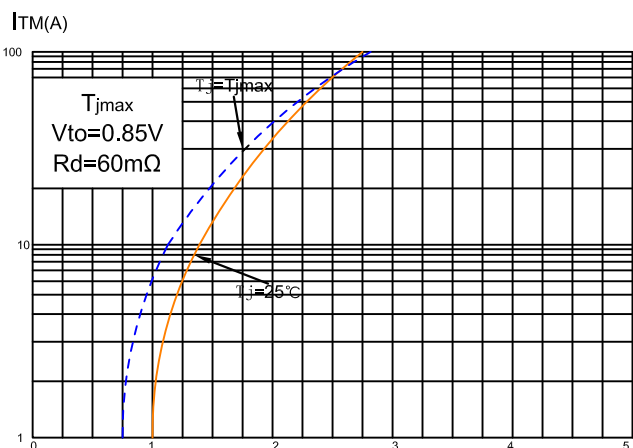

Fig.4 : On-state characteristics (maximum values)

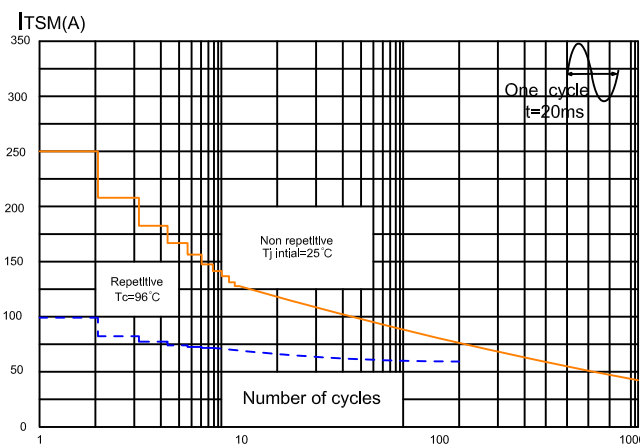

Fig.5 : Non-repetitive surge peak on-state current for a sinusoidal pulse with width $t_p < 10ms$ and corresponding value of $I_t t$ ($dI/dt < 50A/\mu s$)

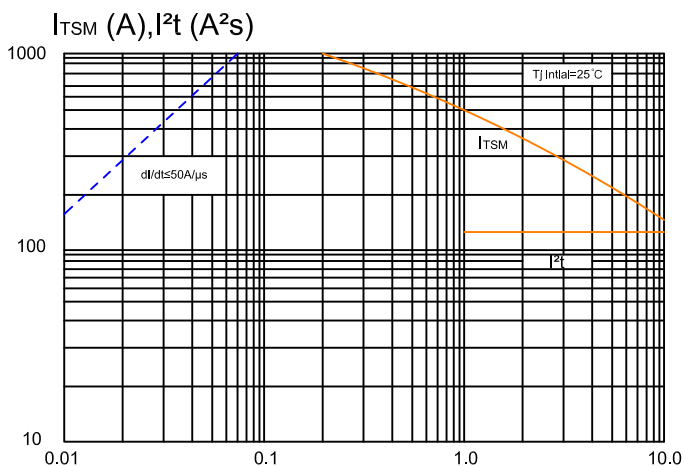
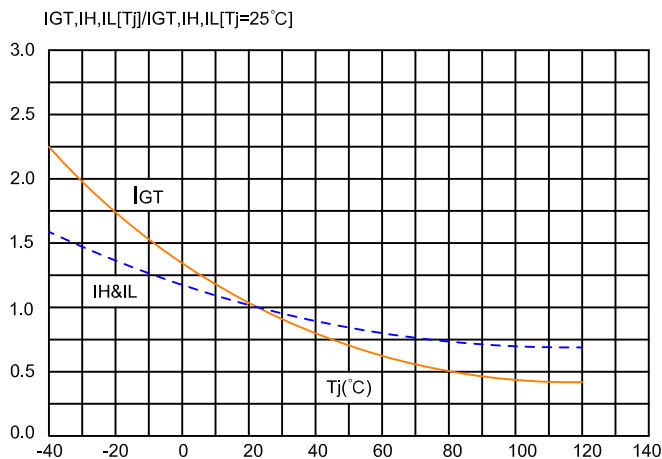
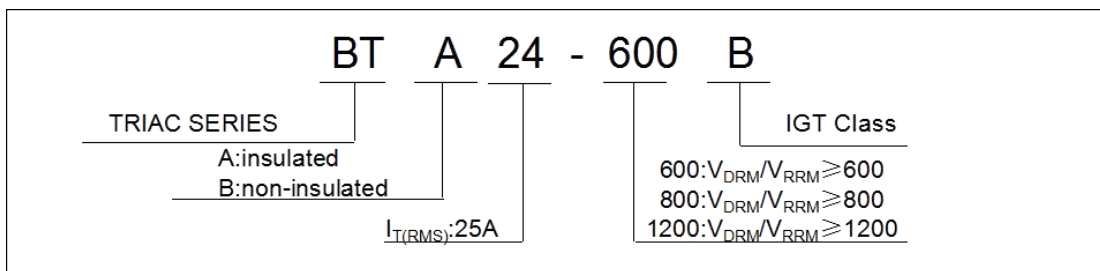

Fig.6: Relative variations of gate trigger current, holding current and latching current versus junction temperature



Ordering Information:



Package Mechanical Data :

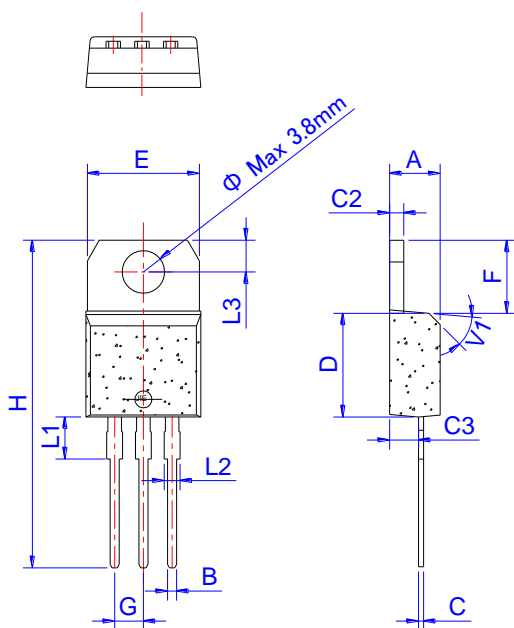

TO-220A Ins

Ref.	Dimensions					
	Millimeters			Inches		
	Min.	Typ.	Max.	Min.	Typ.	Max.
A	4.40		4.60	0.173		0.181
B	0.61		0.88	0.024		0.035
C	0.46		0.70	0.018		0.028
C2	1.21		1.32	0.048		0.052
C3	2.40		2.72	0.094		0.107
D	8.60		9.70	0.339		0.382
E	9.60		10.4	0.378		0.409
F	6.20		6.60	0.244		0.260
G		2.54			0.1	
H	28.0		29.8	1.102		1.173
L1		3.75			0.148	
L2	1.14		1.70	0.045		0.067
L3	2.65		2.95	0.104		0.116
V1		45°			45°	

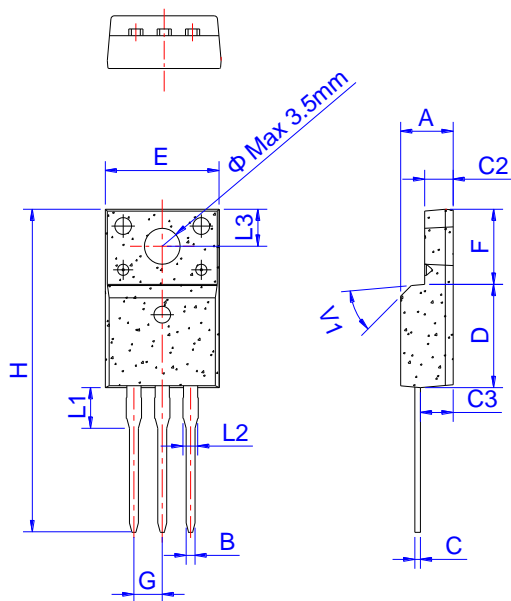

TO-220F Ins

Ref.	Dimensions					
	Millimeters			Inches		
	Min.	Typ.	Max.	Min.	Typ.	Max.
A	4.40		4.80	0.173		0.189
B	0.74	0.80	0.83	0.029	0.031	0.033
C	0.48		0.75	0.019		0.030
C2	2.40		2.70	0.094		0.106
C3	2.60		3.00	0.102		0.118
D	8.80		9.30	0.346		0.366
E	9.70		10.3	0.382		0.406
F	6.40		7.00	0.252		0.276
G		2.54			0.1	
H	28.0		29.8	1.102		1.173
L1		3.63			0.143	
L2	1.14		1.70	0.045		0.067
L3		3.30			0.130	
V1		45°			45°	