

Product Manual

EKWIN ELECTRONICS CO.,LTD

EK BTA80

www.ekwin.net

 Standard TRIACS

BTA80 Serial

Main Features:

$I_{T(RMS)}$	V_{DRM}/V_{RRM}	I_{GT1-3}
80 A	600/800/1200/1600 V	$\leq 50mA$

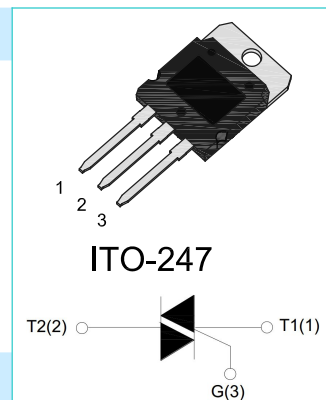

Description:

BTA80 triac provides good commutation capability, which is suitable for general purpose AC switching and voltage regulation, and can be used in static relays, heating regulation, induction motor starting circuits. From all three pins to external heatsink, BTA80 triac provides an insulation voltage of 2500 VRMS.

Absolute Ratings(limiting values) :

Symbol	Parameter	Value	Unit
T_{stg}	Storage junction temperature range	- 40 to + 150	$^{\circ}C$
T_j	Operating junction temperature range	- 40 to + 125	$^{\circ}C$
$I_{T(RMS)}$	RMS on-state current	TO-247S (TC=70 $^{\circ}C$) 80	A
I_{TSM}	Non repetitive surge peak on-state current (tp=10ms)	800	A
V_{DRM}	Repetitive peak off-state voltage(Tj =25 $^{\circ}C$)	600/800/1200/1600	V
V_{RRM}	Repetitive peak reverse voltage(Tj =25 $^{\circ}C$)	600/800/1200/1600	V
V_{DSM}	Non repetitive surge peak Off-state voltage	$V_{DRM} + 100$	V
V_{RSM}	Non repetitive peak reverse voltage	$V_{RRM} + 100$	V
I^2t	I^2t value for fusing tp = 10 ms	3200	A ² s
dI/dt	Critical rate of rise of on-state current ($I_G = 2 \times I_{GT}$)	100	A/ μs

I_{GM}	Peak gate current	8	A
P_{G(AV)}	Average gate power dissipation	2	W
P_{GM}	Peak gate power	10	W

Electrical Characteristics : (T_j=25°C unless otherwise specified)

Symbol	Test Condition	Quadrant	Range	Value	Unit
I_{GT}	V _D =12V R _L =33Ω	I-II-III	MAX	50	mA
V_{GT}		I-II-III	MAX	1.3	V
V_{GD}	V _D =V _{DRM} R _L =3.3kΩ T _j =125°C	I-II-III	MIN	0.2	V
I_L	I _G =1.2 I _{GT}	I-III	MAX	80	mA
		II		120	
I_H	I _{TM} = 100mA		MAX	80	mA
dV/dt	V _D =2/3V _{DRM} Gate Open T _j =125°C		MIN	1500	V/μs

Static Characteristics

Symbol	Parameter		Value(MAX)	Unit
V_{TM}	I _{TM} =120A tp= 380μs	T _j =25°C	1.6	V
I_{DRM} I_{RRM}	V _D =V _{DRM} , V _R =V _{RRM}	T _j =25°C	20	μ A
		T _j =125°C	10	mA

Thermal Resistances :

Symbol	Parameter		Value	Unit
R_{th(j-c)}	Junction to case for AC	ITO-247S(Ins)	0.35	°C/W

Fig.1: Maximum power dissipation versus RMS on-state current

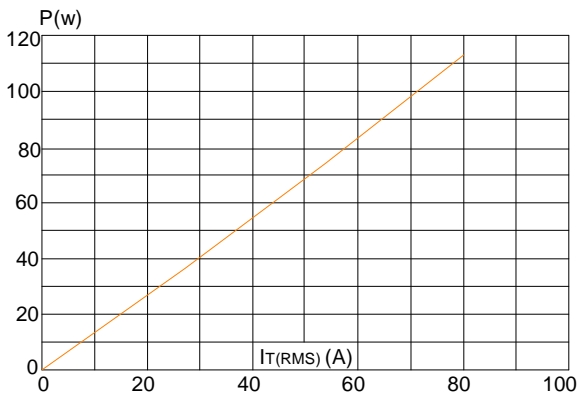

Fig.2 : RMS on-state current versus case temperature

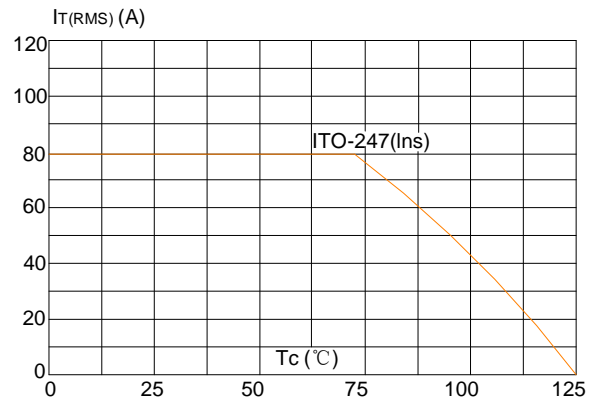

Fig.3 : Surge peak on-state current versus number of cycles

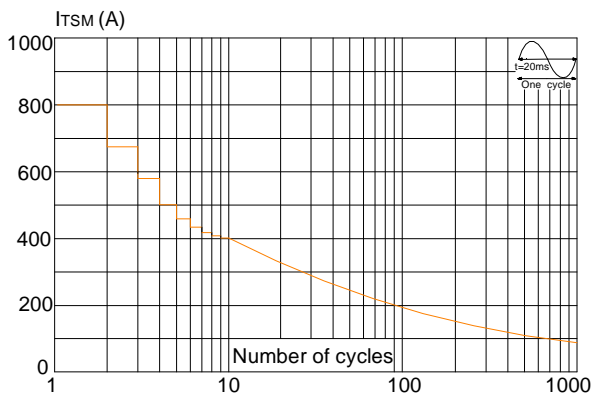

Fig.4 : On-state characteristics (maximum values)

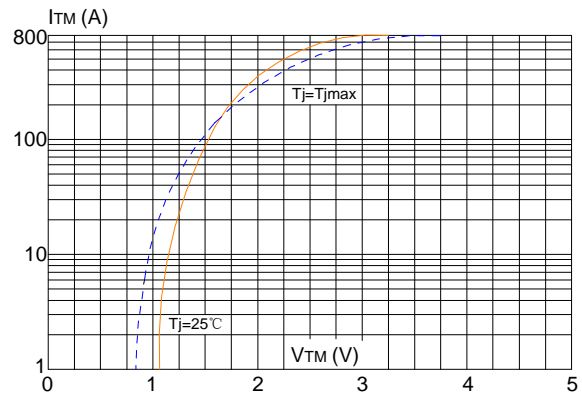

Fig.5 : Non-repetitive surge peak on-state current for a sinusoidal pulse with width $t_p < 20\text{ms}$ and corresponding value of $I_t t$ ($dI/dt < 100\text{A}/\mu\text{s}$)

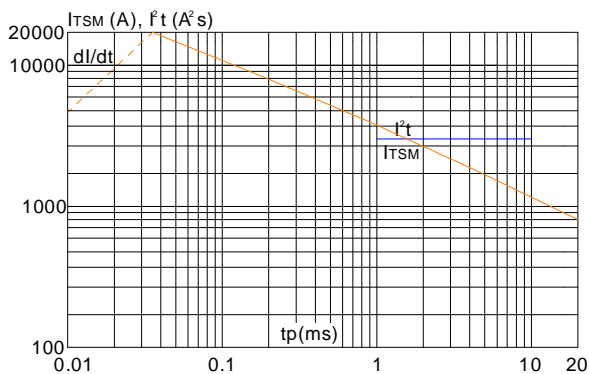
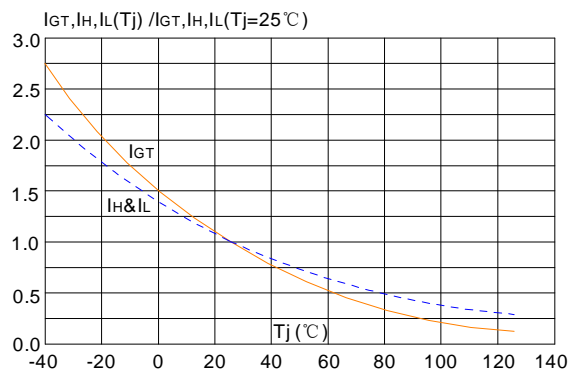
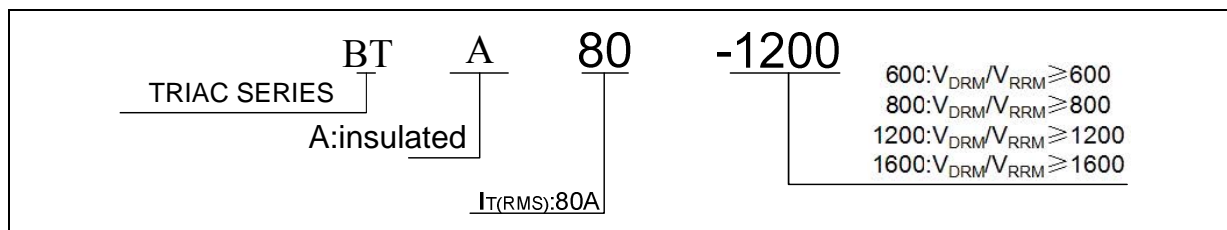

Fig.6: Relative variations of gate trigger current, holding current and latching current versus unjction temperature



Ordering Information:



Package Mechanical Data :

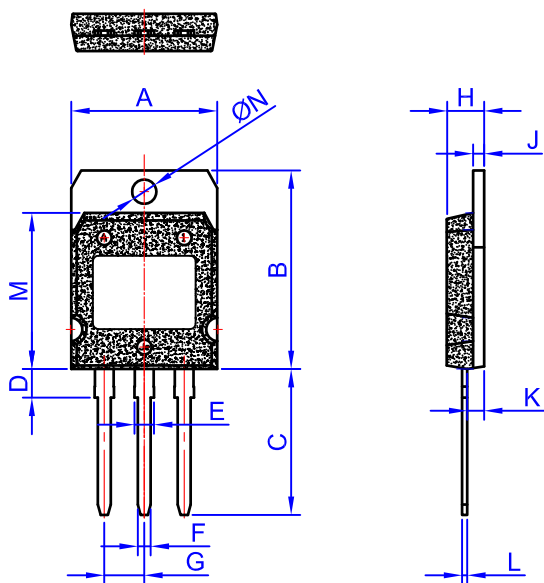

ITO-247

Ref.	Dimensions					
	Millimeters			Inches		
	Min.	Typ.	Max.	Min.	Typ.	Max.
A	19.7	19.9	20.1	0.776	0.783	0.791
B	26.9	27.1	27.3	1.059	1.067	1.075
C	19.4	19.9	20.4	0.764	0.783	0.803
D	3.80	3.90	4.00	0.150	0.154	0.157
E	2.56	2.66	2.76	0.101	0.105	0.109
F	1.66	1.76	1.86	0.065	0.069	0.073
G		5.45			0.215	
H	5.05	5.10	5.50	0.199	0.201	0.217
J	1.45	1.50	1.55	0.057	0.059	0.061
K	2.20	2.30	2.40	0.087	0.091	0.094
L	0.60	0.70	0.80	0.024	0.028	0.031
M	21.2	21.3	21.4	0.835	0.839	0.843
ØN	3.20	3.30	3.40	0.126	0.130	0.134