

Product Manual

EKWIN ELECTRONICS CO.,LTD

EK BTB04

www.ekwin.net

 Standard TRIACS

BTB04 Serial

Main Features:

$I_{T(RMS)}$	V_{DRM}/V_{RRM}	V_{TM}
4 A	600V and 800 V	1.55 V

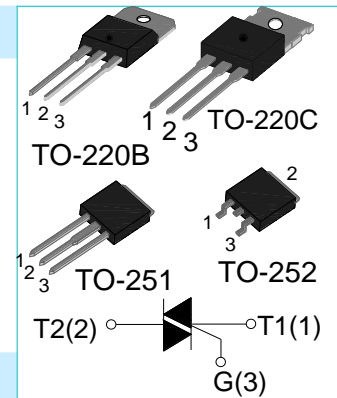

Description:

BTB04 series triacs, with high ability to withstand the shock loading of large current, provide high dv/dt rate with strong resistance to electromagnetic interface. With high commutation performances, 3 quadrants products especially recommended for use on inductive load.

Absolute Ratings(limiting values) :

Symbol	Parameter	Value	Unit	
T_{stg}	Storage junction temperature range	- 40 to + 150	°C	
T_j	Operating junction temperature range	- 40 to + 125	°C	
$I_{T(RMS)}$	RMS on-state current	TO-220BC (TC=95°C)	4	A
		TO-251/TO-252 (TC=86°C)		
I_{TSM}	Non repetitive surge peak on-state current (full cycle,F=50Hz)	40	A	
V_{DRM}	Repetitive peak off-state voltage($T_j = 25^\circ C$)	600 and 800	V	
V_{RRM}	Repetitive peak reverse voltage($T_j = 25^\circ C$)	600 and 800	V	
V_{DSM}	Non repetitive surge peak Off-state voltage	$V_{DRM} + 100$	V	
V_{RSM}	Non repetitive peak reverse voltage	$V_{RRM} + 100$	V	
I^2t	I^2t value for fusing $t_p = 10$ ms	8	A ² s	

dI/dt	Critical rate of rise of on-state current ($I_G = 2 \times I_{GT}$)	50	A/ μ s
I_{GM}	Peak gate current	4	A
P_{G(AV)}	Average gate power dissipation	1	W
P_{GM}	Peak gate power	5	W

Electrical Characteristics :

Symbol	Test Condition	Quadrant	Range	Value				Unit
				T	S	C	B	
I_{GT}	$V_D=12V$ $R_L=33\Omega$	I-II-III	MAX	5	10	35	50	mA
V_{GT}		I-II-III	MAX	1.5				V
V_{GD}	$V_D=V_{DRM}$ $R_L=3.3k\Omega$ $T_j=125^\circ C$	I-II-III	MIN	0.2				V
I_L	$I_G=1.2 I_{GT}$	I-III	MAX	10	20	50	70	mA
		II		15	35	60	80	
I_H	$I_T=100mA$		MAX	10	15	35	60	mA
dV/dt	$V_D=2/3 V_{DRM}$ Gate Open $T_j=125^\circ C$		MIN	20	40	400	1000	V/ μ s
(dV/dt)_c	$(dI/dt)_c=1.8A/ms$ $T_j=125^\circ C$		MIN	0.5	1	-	-	V/ μ s

Static Characteristics

Symbol	Parameter		Value(MAX)	Unit
V_{TM}	$I_{TM}=5.5A$ $tp=380\mu s$	$T_j=25^\circ C$	1.55	V
I_{DRM} I_{RRM}	$V_D=V_{DRM}$, $V_R=V_{RRM}$	$T_j=25^\circ C$	10	μA
		$T_j=125^\circ C$	0.75	mA

Thermal Resistances :

Symbol	Parameter		Value	Unit
R_{th(j-c)}	junction to base(AC)	TO-220BC	2.4	$^\circ C/W$
		TO-251/TO-252	4.2	

FIG.1: Maximum power dissipation versus RMS on-state current

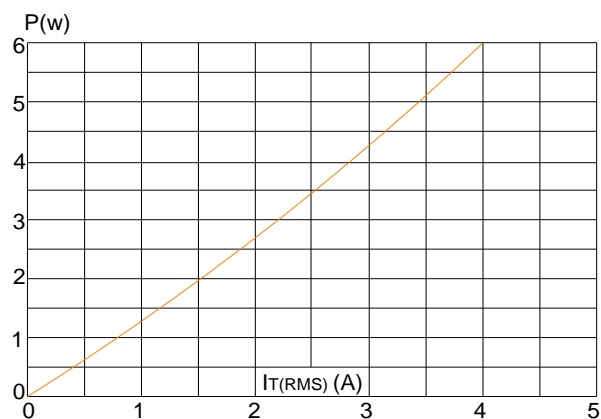

FIG.2: RMS on-state current versus case temperature

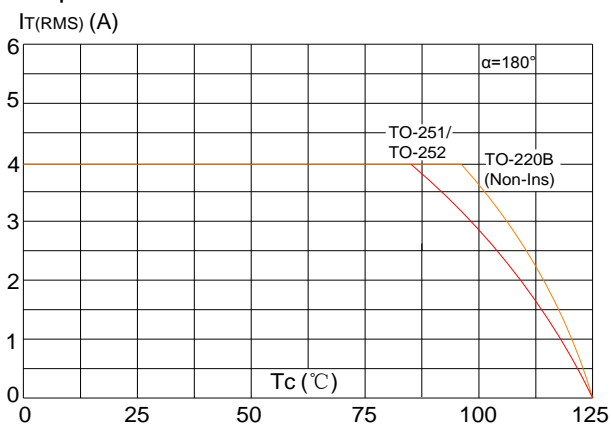

FIG.3: Surge peak on-state current versus number of cycles

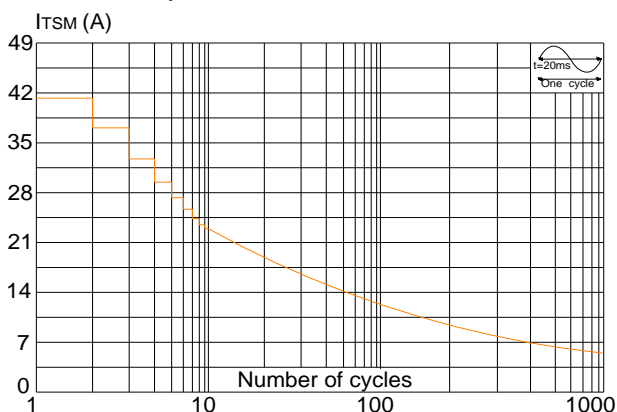

FIG.4: On-state characteristics (maximum values)

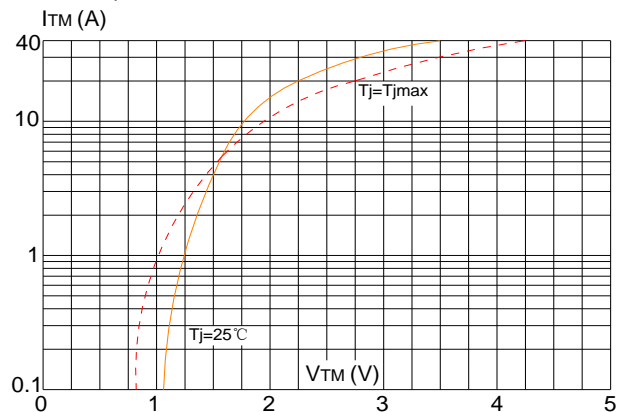

FIG.5: Non-repetitive surge peak on-state current for a sinusoidal pulse with width $t_p < 20ms$ and corresponding value of I^2t ($di/dt < 50A/\mu s$)

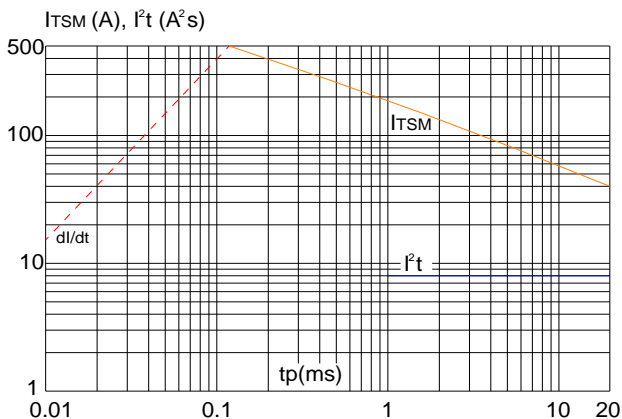
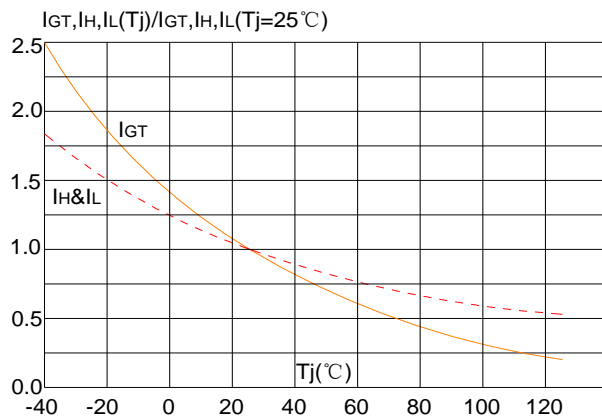
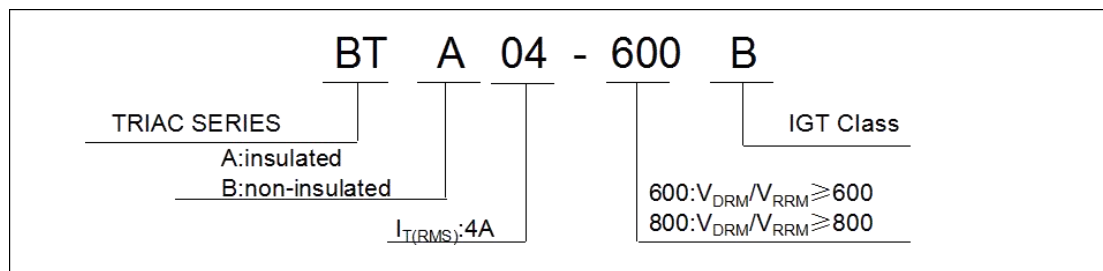

FIG.6: Relative variations of gate trigger current, holding current and latching current versus junction temperature



Ordering Information



Package Mechanical Data :

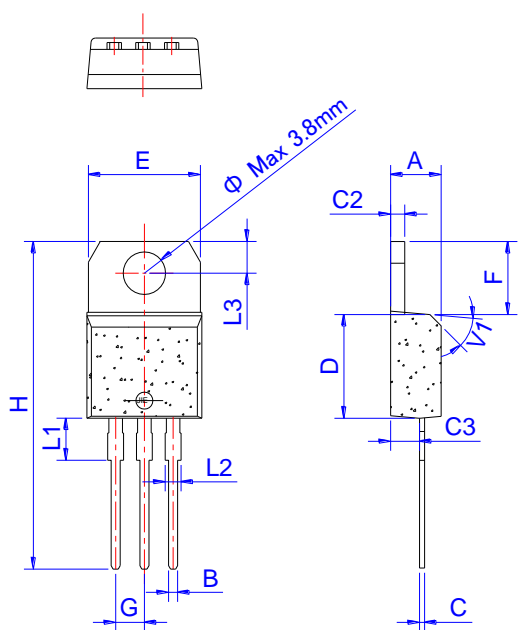

TO-220B Non-Ins

Ref.	Dimensions					
	Millimeters			Inches		
	Min.	Typ.	Max.	Min.	Typ.	Max.
A	4.40		4.60	0.173		0.181
B	0.61		0.88	0.024		0.035
C	0.46		0.70	0.018		0.028
C2	1.21		1.32	0.048		0.052
C3	2.40		2.72	0.094		0.107
D	8.60		9.70	0.339		0.382
E	9.60		10.4	0.378		0.409
F	6.20		6.60	0.244		0.260
G		2.54			0.1	
H	28.0		29.8	1.102		1.173
L1		3.75			0.148	
L2	1.14		1.70	0.045		0.067
L3	2.65		2.95	0.104		0.116
V1		45°			45°	

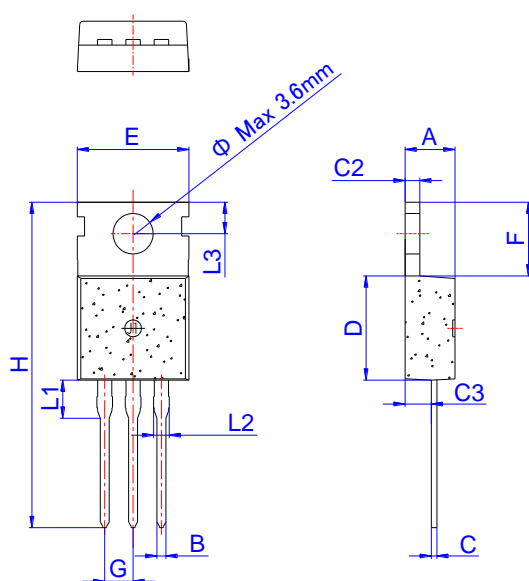

TO-220C

Ref.	Dimensions					
	Millimeters			Inches		
	Min.	Typ.	Max.	Min.	Typ.	Max.
A	4.40		4.60	0.173		0.181
B	0.70		0.90	0.028		0.035
C	0.45		0.60	0.018		0.024
C2	1.23		1.32	0.048		0.052
C3	2.20		2.60	0.087		0.102
D	8.90		9.90	0.350		0.390
E	9.90		10.3	0.390		0.406
F	6.30		6.90	0.248		0.272
G		2.54			0.1	
H	28.0		29.8	1.102		1.173
L1		3.39			0.133	
L2	1.14		1.70	0.045		0.067
L3	2.65		2.95	0.104		0.116
Phi		3.6			0.142	

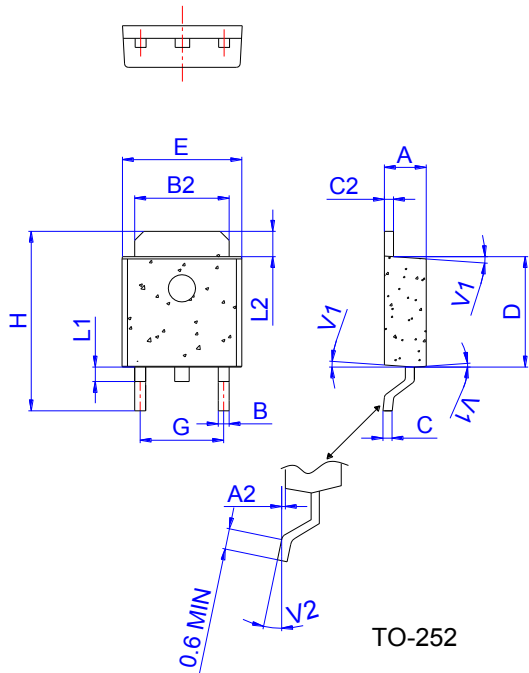

Ref.	Dimensions					
	Millimeters			Inches		
	Min.	Typ.	Max.	Min.	Typ.	Max.
A	2.20		2.40	0.086		0.095
A2	0.03		0.23	0.001		0.009
B	0.55		0.65	0.022		0.026
B2	5.10		5.40	0.200		0.213
C	0.45		0.62	0.018		0.024
C2	0.48		0.62	0.019		0.024
D	6.00		6.20	0.236		0.244
E	6.40		6.70	0.252		0.264
G	4.40		4.70	0.173		0.185
H	9.35		10.6	0.368		0.417
L1	1.30		1.70	0.051		0.067
L2	1.37		1.50	0.054		0.059
V1		4°			4°	
V2	0°		8°	0°		8°

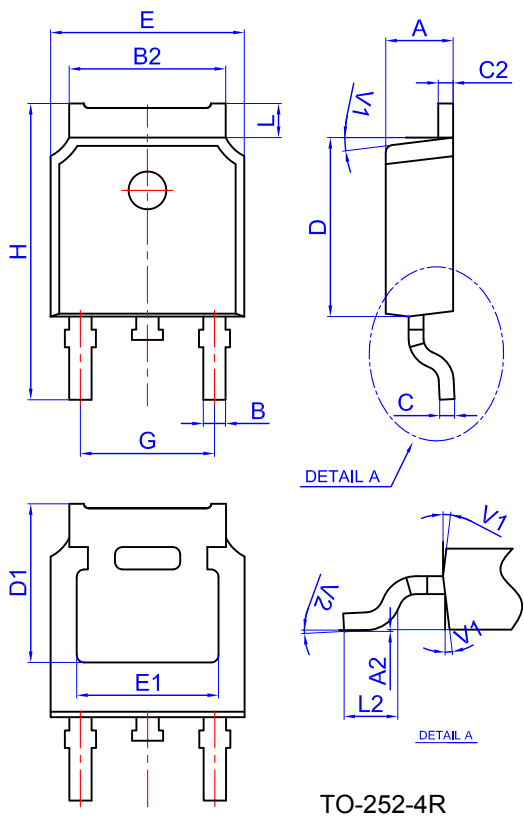

Ref.	Dimensions					
	Millimeters			Inches		
	Min.	Typ.	Max.	Min.	Typ.	Max.
A	2.10		2.50	0.083		0.098
A2	0		0.10	0		0.004
B	0.66		0.86	0.026		0.034
B2	5.18		5.48	0.202		0.216
C	0.40		0.60	0.016		0.024
C2	0.44		0.58	0.017		0.023
D	5.90		6.30	0.232		0.248
D1	5.30REF			0.209REF		
E	6.40		6.80	0.252		0.268
E1	4.63			0.182		
G	4.47		4.67	0.176		0.184
H	9.50		10.70	0.374		0.421
L	1.09		1.21	0.043		0.048
L2	1.35		1.65	0.053		0.065
V1		7°			7°	
V2	0°		6°	0°		6°

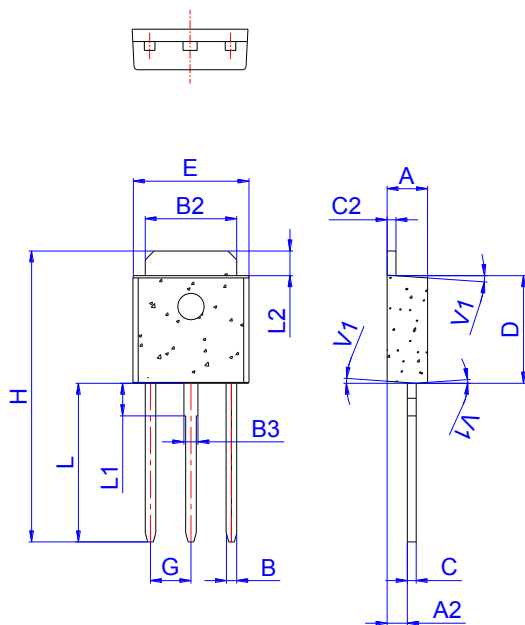

TO-251

Ref.	Dimensions					
	Millimeters			Inches		
	Min.	Typ.	Max.	Min.	Typ.	Max.
A	2.20		2.40	0.086		0.095
A2	0.90		1.20	0.035		0.047
B	0.55		0.65	0.022		0.026
B2	5.10		5.40	0.200		0.213
B3	0.76		0.85	0.030		0.033
C	0.45		0.62	0.018		0.024
C2	0.48		0.62	0.019		0.024
D	6.00		6.20	0.236		0.244
E	6.40		6.70	0.252		0.264
G		2.30			0.091	
H	16.0		17.0	0.630		0.669
L	8.90		9.40	0.350		0.370
L1	1.80		1.90	0.071		0.075
L2	1.37		1.50	0.054		0.059
V1		4°			4°	