

Product Manual

EKWIN ELECTRONICS CO.,LTD

EK BTB08

www.ekwin.net

 Standard TRIACS

BTB08 Serial

Main Features:

$I_{T(RMS)}$	V_{DRM}/V_{RRM}	V_{TM}
8 A	600V 800V	≤ 1.55 V

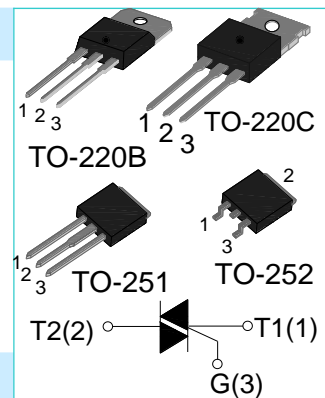

Description:

High current density due to double mesa technology; Glass Passivation. BTB08 series TRIACS is suitable for general purpose AC switching. They can be used as an ON/OFF Function in applications such as static relays, heating regulation, induction motor starting circuits, or for phase control operation light dimmers, motor speed controllers.

Absolute Ratings (limiting values) :

Symbol	Parameter	Value	Unit	
T_{stg}	Storage junction temperature range	- 40 to + 150	$^{\circ}C$	
T_j	Operating junction temperature range	- 40 to + 125	$^{\circ}C$	
$I_{T(RMS)}$	RMS on-state current	TO-220BC(Non-Ins) (TC=107 $^{\circ}C$)	8	A
		TO-251/TO-252 (TC=107 $^{\circ}C$)		
I_{TSM}	Non repetitive surge peak on-state current (tp=10ms)	80	A	
V_{DRM}	Repetitive peak off-state voltage(Tj =25 $^{\circ}C$)	600/800	V	
V_{RRM}	Repetitive peak reverse voltage(Tj =25 $^{\circ}C$)	600/800	V	
V_{DSM}	Non repetitive surge peak Off-state voltage	$V_{DRM} + 100$	V	
V_{RSM}	Non repetitive peak reverse voltage	$V_{RRM} + 100$	V	
I^2t	I^2t value for fusing tp = 10 ms	32	A ² s	
dI/dt	Critical rate of rise of on-state current ($I_G = 2 \times I_{GT}$)	50	A/ μ s	

I_{GM}	Peak gate current	4	A
P_{G(AV)}	Average gate power dissipation	1	W
P_{GM}	Peak gate power	5	W

Electrical Characteristics : (T_j=25°C unless otherwise specified)

Symbol	Test Condition	Quadrant	Range	Value				Unit
				T	S	C	B	
I_{GT}	V _D =12V R _L =33Ω	I-II-III	MAX	5	10	35	50	mA
V_{GT}		I-II-III	MAX	1.5				V
V_{GD}	V _D =V _{DRM} R _L =3.3kΩ T _j =125°C	I-II-III	MIN	0.2				V
I_L	I _G =1.2 I _{GT}	I-III	MAX	15	20	50	70	mA
		II		25	35	60	80	
I_H	I _{TM} = 100mA		MAX	10	15	40	60	mA
dV/dt	V _D =2/3V _{DRM} Gate Open T _j =125°C		MIN	50	200	500	1000	V/μs

Static Characteristics

Symbol	Parameter		Value(MAX)	Unit
V_{TM}	I _{TM} =11A tp= 380μs	T _j =25°C	1.55	V
I_{DRM} I_{RRM}	V _D =V _{DRM} , V _R =V _{RRM}	T _j =25°C	5	μ A
		T _j =125°C	1	mA

Thermal Resistances :

Symbol	Parameter		Value	Unit
R_{th(j-c)}	Junction to case for AC	TO-251/TO-252	3.5	°C/W
		TO-220BC(Non-Ins)	2.4	

FIG.1 Maximum power dissipation versus RMS on-state current

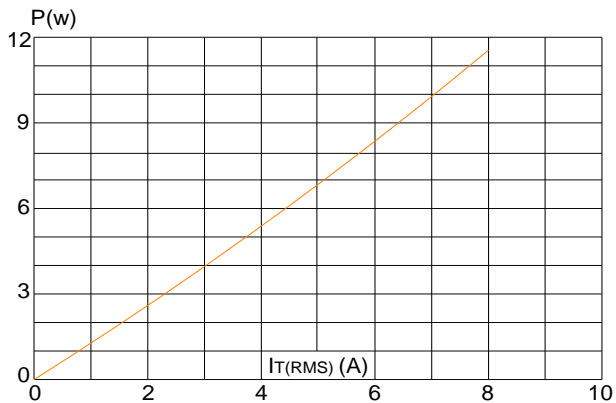

FIG.2: RMS on-state current versus case temperature

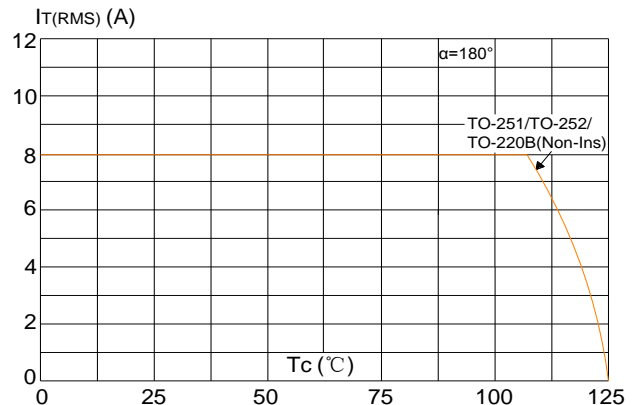

FIG.3: Surge peak on-state current versus number of cycles

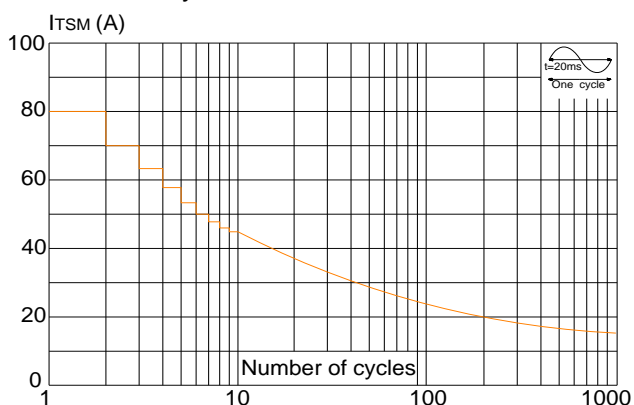

FIG.4: On-state characteristics (maximum values)

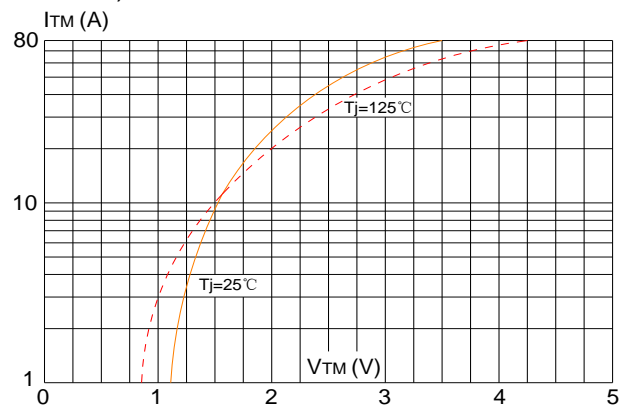

FIG.5: Non-repetitive surge peak on-state current for a sinusoidal pulse with width $t_p < 20ms$, and corresponding value of I^2t ($di/dt < 50A/\mu s$)

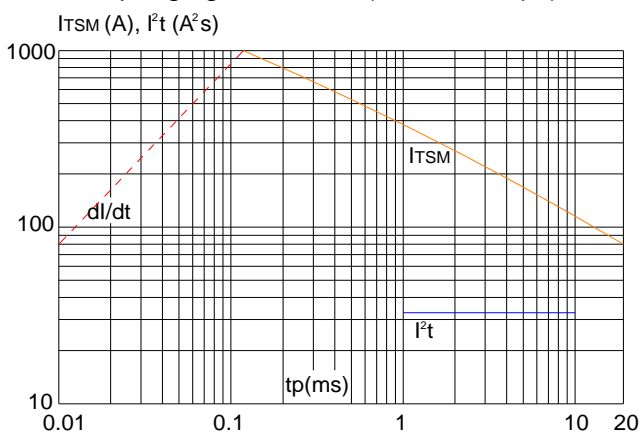
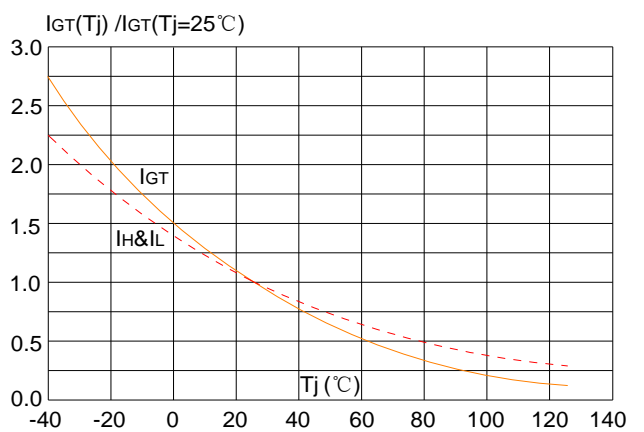
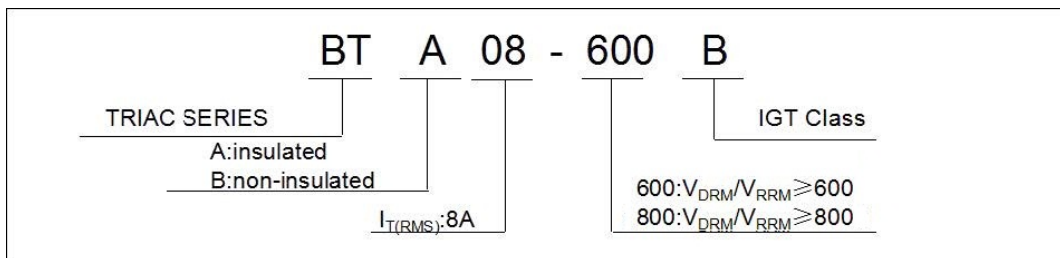

FIG.6: Relative variations of gate trigger current, holding current and latching current versus junction temperature



Ordering Information:



Package Mechanical Data :

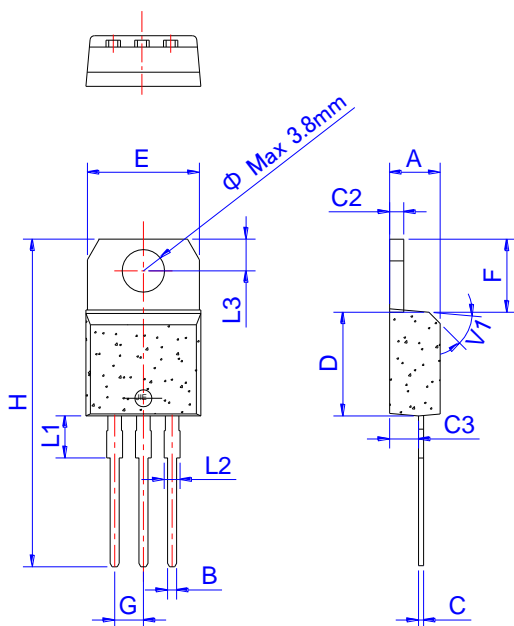

TO-220B Non-Ins

Ref.	Dimensions					
	Millimeters			Inches		
	Min.	Typ.	Max.	Min.	Typ.	Max.
A	4.40		4.60	0.173		0.181
B	0.61		0.88	0.024		0.035
C	0.46		0.70	0.018		0.028
C2	1.21		1.32	0.048		0.052
C3	2.40		2.72	0.094		0.107
D	8.60		9.70	0.339		0.382
E	9.60		10.4	0.378		0.409
F	6.20		6.60	0.244		0.260
G		2.54			0.1	
H	28.0		29.8	1.102		1.173
L1		3.75			0.148	
L2	1.14		1.70	0.045		0.067
L3	2.65		2.95	0.104		0.116
V1		45°			45°	

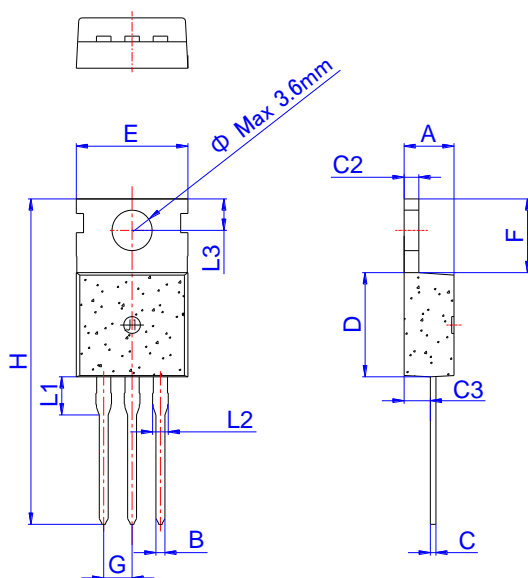

TO-220C

Ref.	Dimensions					
	Millimeters			Inches		
	Min.	Typ.	Max.	Min.	Typ.	Max.
A	4.40		4.60	0.173		0.181
B	0.70		0.90	0.028		0.035
C	0.45		0.60	0.018		0.024
C2	1.23		1.32	0.048		0.052
C3	2.20		2.60	0.087		0.102
D	8.90		9.90	0.350		0.390
E	9.90		10.3	0.390		0.406
F	6.30		6.90	0.248		0.272
G		2.54			0.1	
H	28.0		29.8	1.102		1.173
L1		3.39			0.133	
L2	1.14		1.70	0.045		0.067
L3	2.65		2.95	0.104		0.116
Φ		3.6			0.142	

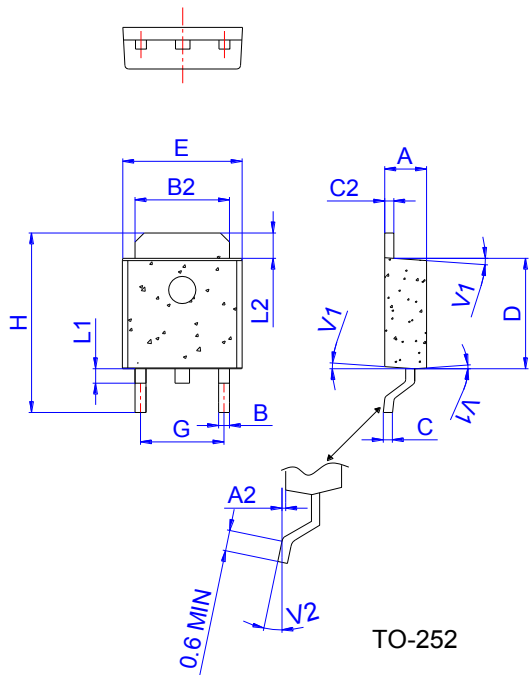

Ref.	Dimensions					
	Millimeters			Inches		
	Min.	Typ.	Max.	Min.	Typ.	Max.
A	2.20		2.40	0.086		0.095
A2	0.03		0.23	0.001		0.009
B	0.55		0.65	0.022		0.026
B2	5.10		5.40	0.200		0.213
C	0.45		0.62	0.018		0.024
C2	0.48		0.62	0.019		0.024
D	6.00		6.20	0.236		0.244
E	6.40		6.70	0.252		0.264
G	4.40		4.70	0.173		0.185
H	9.35		10.6	0.368		0.417
L1	1.30		1.70	0.051		0.067
L2	1.37		1.50	0.054		0.059
V1		4°			4°	
V2	0°		8°	0°		8°

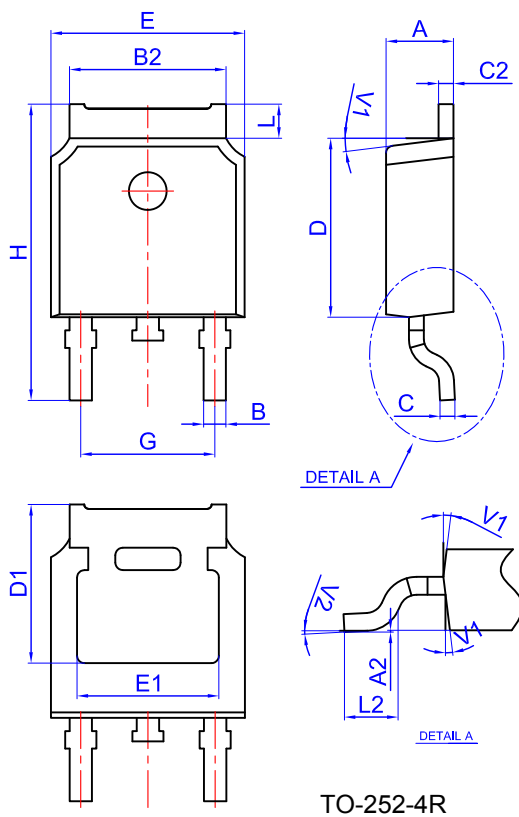

Ref.	Dimensions					
	Millimeters			Inches		
	Min.	Typ.	Max.	Min.	Typ.	Max.
A	2.10		2.50	0.083		0.098
A2	0		0.10	0		0.004
B	0.66		0.86	0.026		0.034
B2	5.18		5.48	0.202		0.216
C	0.40		0.60	0.016		0.024
C2	0.44		0.58	0.017		0.023
D	5.90		6.30	0.232		0.248
D1	5.30REF			0.209REF		
E	6.40		6.80	0.252		0.268
E1	4.63			0.182		
G	4.47		4.67	0.176		0.184
H	9.50		10.70	0.374		0.421
L	1.09		1.21	0.043		0.048
L2	1.35		1.65	0.053		0.065
V1		7°			7°	
V2	0°		6°	0°		6°

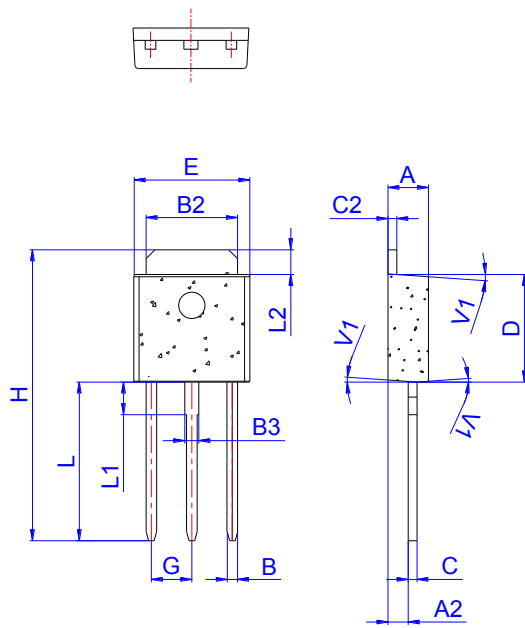

TO-251

Ref.	Dimensions					
	Millimeters			Inches		
	Min.	Typ.	Max.	Min.	Typ.	Max.
A	2.20		2.40	0.086		0.095
A2	0.90		1.20	0.035		0.047
B	0.55		0.65	0.022		0.026
B2	5.10		5.40	0.200		0.213
B3	0.76		0.85	0.030		0.033
C	0.45		0.62	0.018		0.024
C2	0.48		0.62	0.019		0.024
D	6.00		6.20	0.236		0.244
E	6.40		6.70	0.252		0.264
G		2.30			0.091	
H	16.0		17.0	0.630		0.669
L	8.90		9.40	0.350		0.370
L1	1.80		1.90	0.071		0.075
L2	1.37		1.50	0.054		0.059
V1		4°			4°	