

Product Manual

EKWIN ELECTRONICS CO.,LTD

EK T4xxH

www.ekwin.net

 High junction temperature TRIACS

T4xxH series

Main Features:

$I_{T(RMS)}$	V_{DRM}/V_{RRM}	V_{TM}
4 A	600V and 800 V	$\leq 1.55 V$

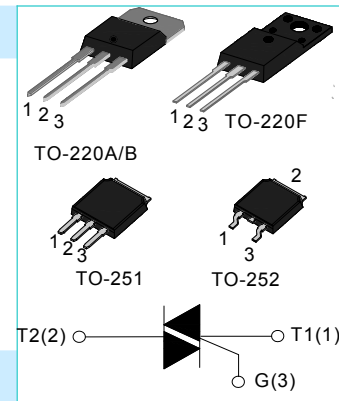

Description:

High current density due to single mesa technology; Glass Passivation, guaranteed maximum junction temperature 150°C T4xxH series triacs is suitable for general purpose AC switching. They can be used as an ON/OFF Function in applications such as static relays, heating regulation motor starting circuits...or for phase control operation light dimmers, motor speed controllers. T4xxH series are 3 Quadrants triacs. They are specially recommended for use on inductive loads

Absolute Ratings(limiting values) :

Symbol	Parameter	Value	Unit	
T_{stg}	Storage junction temperature range	- 40 to + 150	°C	
T_j	Operating junction temperature range	- 40 to +150	°C	
$I_{T(RMS)}$	RMS on-state current	TO-220A(Ins) (TC=95°C)	4	A
		TO-220B (TC=110°C)		
		TO-251/252(TC=100°C)		
		TO-220F(Ins) (TC=87°C)		
I_{TSM}	Non repetitive surge peak on-state current (full cycle, F=50Hz)	40	A	
V_{DRM}	Repetitive peak off-state voltage($T_j = 25^\circ C$)	600 and 800	V	
V_{RRM}	Repetitive peak reverse voltage($T_j = 25^\circ C$)	600 and 800	V	
V_{DSM}	Non repetitive surge peak Off-state voltage	$V_{DRM} + 100$	V	
V_{RSM}	Non repetitive peak reverse voltage	$V_{RRM} + 100$	V	
I^2t	I^2t value for fusing $t_p = 10$ ms	8	A ² s	

dI/dt	Critical rate of rise of on-state current ($I_G = 2 \times I_{GT}$)	50	A/ μ s
I_{GM}	Peak gate current	2	A
P_{G(AV)}	Average gate power dissipation	1	W
P_{GM}	Peak gate power	5	W

Electrical Characteristics : (T_j=25°C unless otherwise specified)

Symbol	Test Condition	Quadrant	Range	Value				Unit
				T410H	T420H	T435H	T450H	
I_{GT}	V _D =12V R _L =33 Ω	I-II-III	MAX	10	20	35	50	mA
V_{GT}		I-II-III	MAX	1.5				V
V_{GD}	V _D =V _{DRM} R _L =3.3k Ω T _j =150°C	I-II-III	MIN	0.2				V
I_L	I _G =1.2 I _{GT}	I-III	MAX	20	40	50	70	mA
		II		35	55	70	80	
I_H	I _{TM} = 100mA		MAX	20	30	45	60	mA
dV/dt	V _D =2/3V _{DRM} Gate Open T _j =150°C		MIN	200	500	1000	1500	V/ μ s
(dV/dt)_c	(dI/dt) _c = -1.7A/ms T _j = 150°C		MIN	1	5	15	25	V/ μ s

Static Characteristics

Symbol	Parameter	Value(MAX)	Unit	
V_{TM}	I _{TM} =5.5A tp= 380 μ s	T _j =25°C	1.55	V
I_{DRM} I_{RRM}	V _D =V _{DRM} , V _R =V _{RRM}	T _j =25°C	5	μ A
		T _j =150°C	1	mA

Thermal Resistances :

Symbol	Parameter	TO-220F(Ins)	Value	Unit
R_{th(j-c)}	Junction to case for AC	TO-220A(Ins) (TC=95°C)	3.2	°C/W
		TO-220B (TC=110°C)	2.5	
		TO-251/252(TC=100°C)	2.8	
		TO-220F(Ins) (TC=87°C)	3.4	

FIG.1:Maximum power dissipation versus RMS on-state current(full cycle)

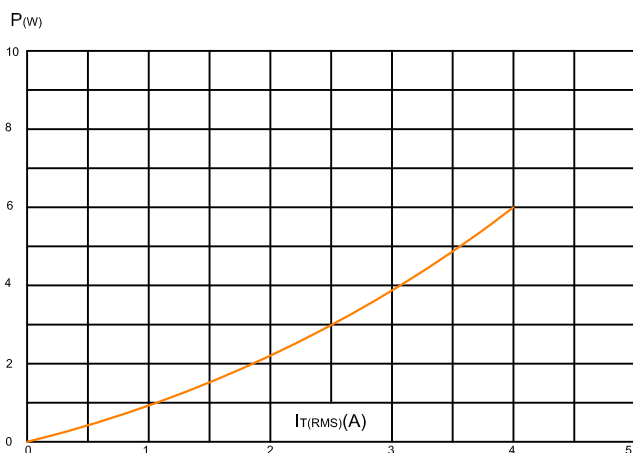

FIG.3:On-state characteristics (maximum values).

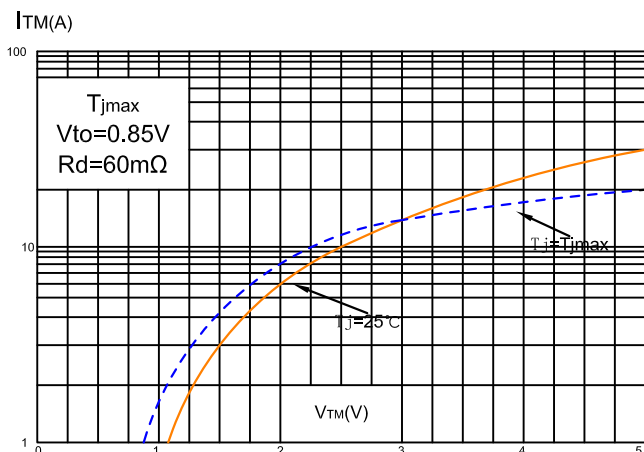

FIG.5:Non-repetitive surge peak on-state current for a sinusoidal pulse with width $t_p < 10\text{ms}$, and corresponding value of I^2t .

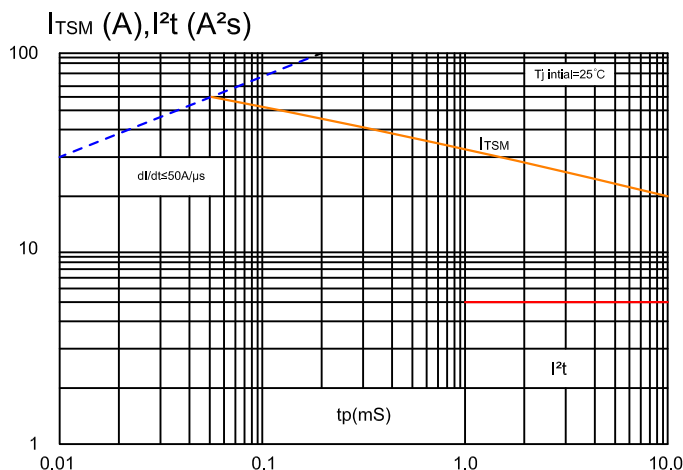

FIG.2:RMS on-state current versus case temperature(full cycle)

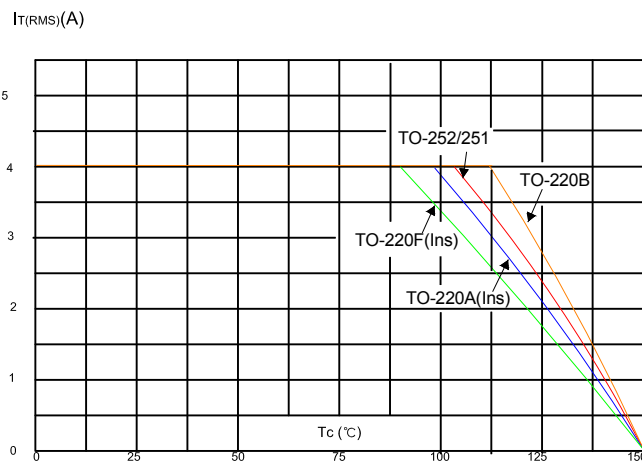

FIG.4:Surge peak on-state current versus number of cycles.

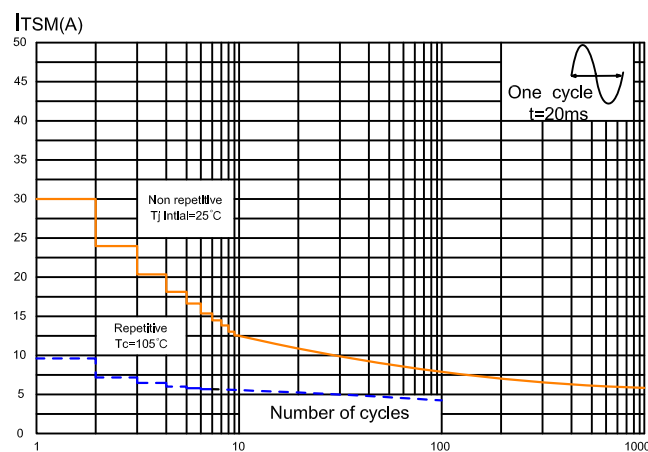
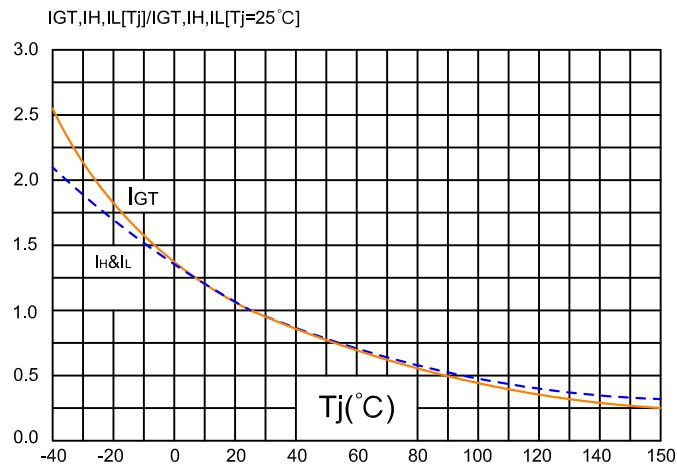
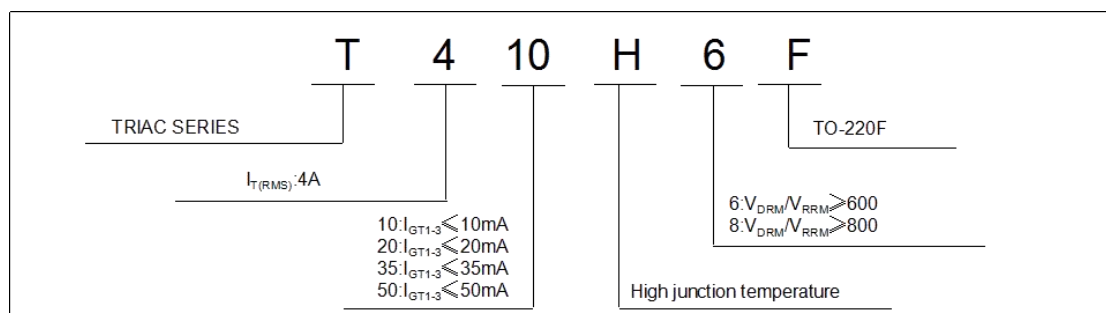

FIG.6:Relative variations of gate trigger current,holding current and latching current versus junction temperature(typical values)



Ordering Information:



Package Mechanical Data :

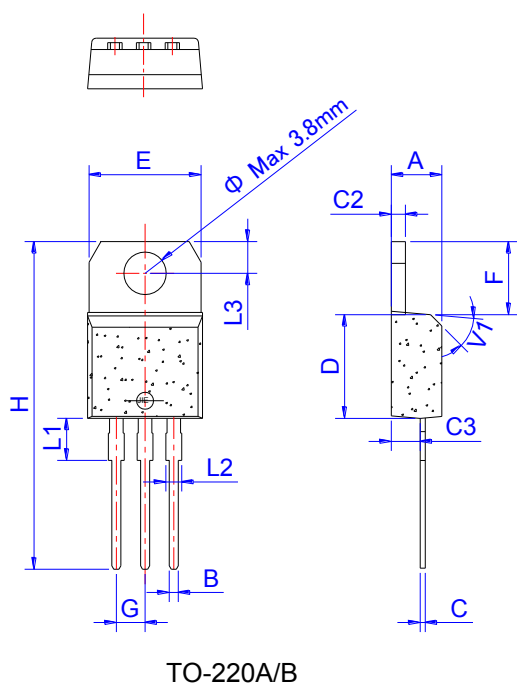

Ref.	Dimensions					
	Millimeters			Inches		
	Min.	Typ.	Max.	Min.	Typ.	Max.
A	4.40		4.60	0.173		0.181
B	0.61		0.88	0.024		0.035
C	0.46		0.70	0.018		0.028
C2	1.21		1.32	0.048		0.052
C3	2.40		2.72	0.094		0.107
D	8.60		9.70	0.339		0.382
E	9.60		10.4	0.378		0.409
F	6.20		6.60	0.244		0.260
G		2.54			0.1	
H	28.0		29.8	1.102		1.173
L1		3.75			0.148	
L2	1.14		1.70	0.045		0.067
L3	2.65		2.95	0.104		0.116
V1		45°			45°	

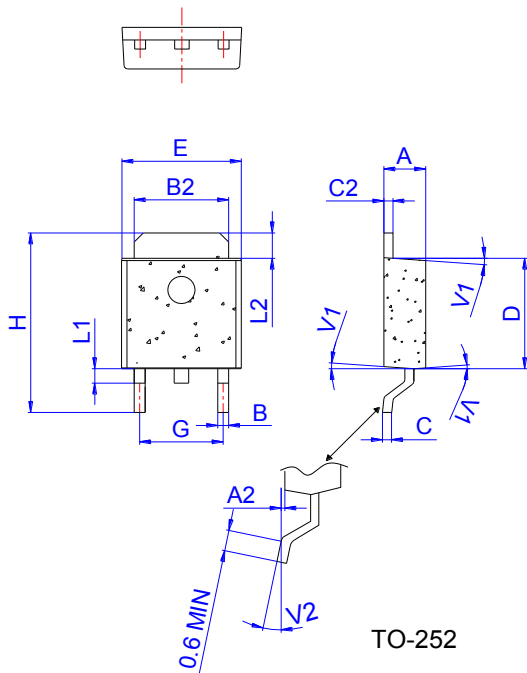

Ref.	Dimensions					
	Millimeters			Inches		
	Min.	Typ.	Max.	Min.	Typ.	Max.
A	2.20		2.40	0.086		0.095
A2	0.03		0.23	0.001		0.009
B	0.55		0.65	0.022		0.026
B2	5.10		5.40	0.200		0.213
C	0.45		0.62	0.018		0.024
C2	0.48		0.62	0.019		0.024
D	6.00		6.20	0.236		0.244
E	6.40		6.70	0.252		0.264
G	4.40		4.70	0.173		0.185
H	9.35		10.6	0.368		0.417
L1	1.30		1.70	0.051		0.067
L2	1.37		1.50	0.054		0.059
V1		4°			4°	
V2	0°		8°	0°		8°

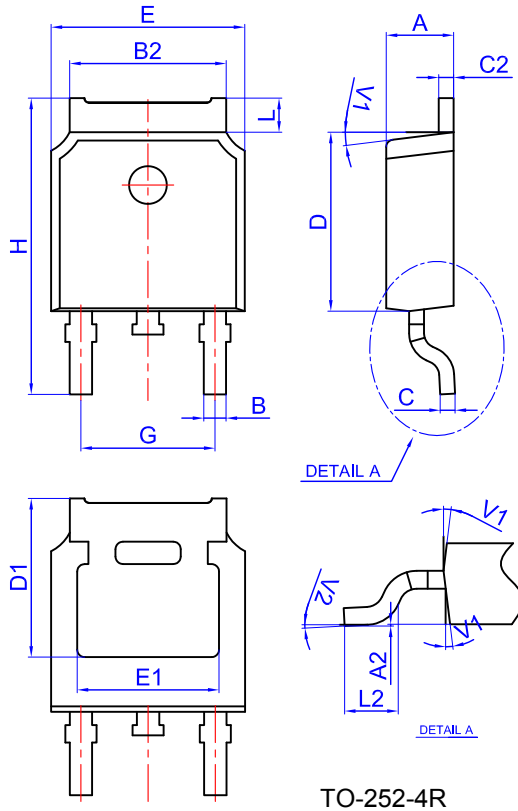

Ref.	Dimensions					
	Millimeters			Inches		
	Min.	Typ.	Max.	Min.	Typ.	Max.
A	2.10		2.50	0.083		0.098
A2	0		0.10	0		0.004
B	0.66		0.86	0.026		0.034
B2	5.18		5.48	0.202		0.216
C	0.40		0.60	0.016		0.024
C2	0.44		0.58	0.017		0.023
D	5.90		6.30	0.232		0.248
D1	5.30REF			0.209REF		
E	6.40		6.80	0.252		0.268
E1	4.63			0.182		
G	4.47		4.67	0.176		0.184
H	9.50		10.70	0.374		0.421
L	1.09		1.21	0.043		0.048
L2	1.35		1.65	0.053		0.065
V1		7°			7°	
V2	0°		6°	0°		6°

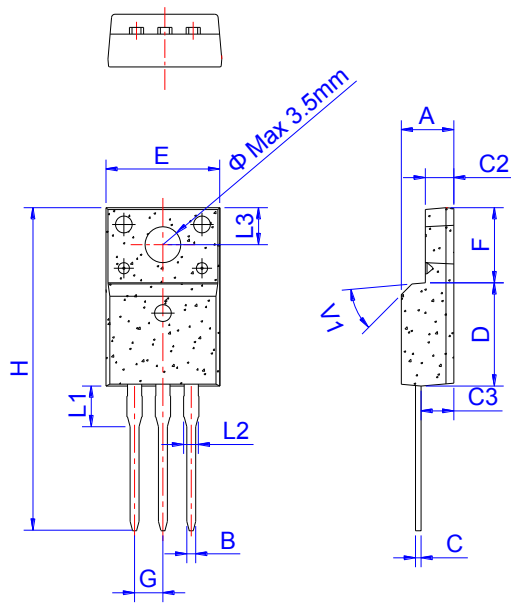

TO-220F

Ref.	Dimensions					
	Millimeters			Inches		
	Min.	Typ.	Max.	Min.	Typ.	Max.
A	4.40		4.80	0.173		0.189
B	0.74	0.80	0.83	0.029	0.031	0.033
C	0.48		0.75	0.019		0.030
C2	2.40		2.70	0.094		0.106
C3	2.60		3.00	0.102		0.118
D	8.80		9.30	0.346		0.366
E	9.70		10.3	0.382		0.406
F	6.40		7.00	0.252		0.276
G		2.54			0.1	
H	28.0		29.8	1.102		1.173
L1		3.63			0.143	
L2	1.14		1.70	0.045		0.067
L3		3.30			0.130	
V1		45°			45°	

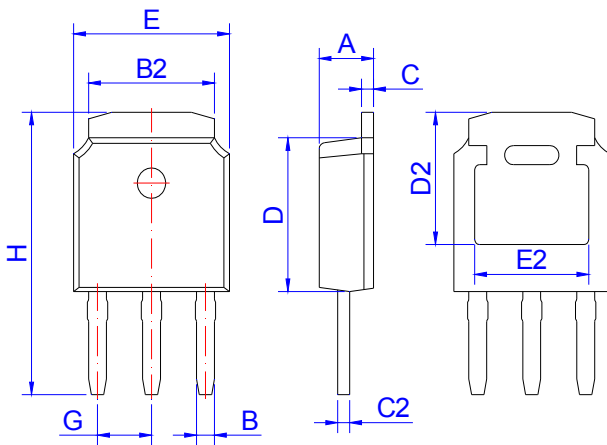

TO-251

Ref.	Dimensions					
	Millimeters			Inches		
	Min.	Typ.	Max.	Min.	Typ.	Max.
A	2.10	2.30	2.50	0.083	0.091	0.098
B	0.66	0.76	0.86	0.026	0.030	0.034
B2	5.15	5.33	5.48	0.203	0.210	0.216
C	0.44	0.51	0.58	0.017	0.020	0.023
C2	0.44	0.51	0.58	0.017	0.020	0.023
D	5.90	6.10	6.30	0.232	0.240	0.248
D2	5.30 REF			0.209 REF		
E	6.40	6.60	6.80	0.252	0.260	0.268
E2	4.83 REF			0.190 REF		
G	2.19	2.29	2.39	0.086	0.090	0.094
H	10.60	11.20	11.80	0.417	0.441	0.465