

Product Manual

EKWIN ELECTRONICS CO.,LTD

EK T12xxH

www.ekwin.net

High junction temperature TRIACS
T12xxH series
Main Features:

$I_{T(RMS)}$	V_{DRM}/V_{RRM}	V_{TM}
12 A	600V and 800 V	≤ 1.55 V

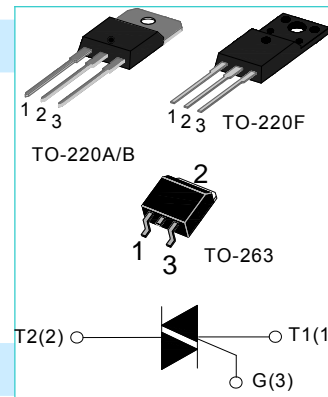
Description:

High current density due to single mesa technology; Glass Passivation, guaranteed maximum junction temperature 150°C T12xxH series triacs is suitable for general purpose AC switching. They can be used as an ON/OFF Function in applications such as static relays, heating regulation motor starting circuits...or for phase control operation light dimmers, motor speed controllers. T12xxH series are 3 Quadrants triacs. They are specially recommended for use on inductive loads

Absolute Ratings (limiting values) :

Symbol	Parameter	Value	Unit	
T_{stg}	Storage junction temperature range	- 40 to + 150	°C	
T_j	Operating junction temperature range	- 40 to +150	°C	
$I_{T(RMS)}$	RMS on-state current	TO-220A (Ins) (TC=100°C)	12	A
		TO-220B (TC=113°C)		
		TO-220F(Ins) (TC=95°C)		
		TO-263 (TC=118°C)		
I_{TSM}	Non repetitive surge peak on-state current (full cycle, F=50Hz)	120	A	
V_{DRM}	Repetitive peak off-state voltage($T_j = 25^\circ\text{C}$)	600 and 800	V	
V_{RRM}	Repetitive peak reverse voltage($T_j = 25^\circ\text{C}$)	600 and 800	V	
V_{DSM}	Non repetitive surge peak Off-state voltage	$V_{DRM} + 100$	V	
V_{RSM}	Non repetitive peak reverse voltage	$V_{RRM} + 100$	V	
I^2t	I^2t value for fusing $t_p = 10$ ms	78	A ² s	

dI/dt	Critical rate of rise of on-state current ($I_G = 2 \times I_{GT}$)	50	A/ μ s
I_{GM}	Peak gate current	2	A
P_{G(AV)}	Average gate power dissipation	1	W
P_{GM}	Peak gate power	5	W

Electrical Characteristics : (T_j=25°C unless otherwise specified)

Symbol	Test Condition	Quadrant	Range	Value				Unit
				T1210H	T1220H	T1235H	T1250H	
I_{GT}	V _D =12V R _L =33 Ω	I-II-III	MAX	10	20	35	50	mA
V_{GT}		I-II-III	MAX	1.5				V
V_{GD}	V _D =V _{DRM} R _L =3.3k Ω T _j =150°C	I-II-III	MIN	0.2				V
I_L	I _G =1.2 I _{GT}	I-III	MAX	20	40	50	70	mA
		II		35	55	70	100	
I_H	I _{TM} = 100mA		MAX	20	30	45	60	mA
dV/dt	V _D =2/3V _{DRM} R _{GK} =1k Ω T _j =150°C		MIN	200	500	1000	1500	V/ μ s
(dV/dt)_c	(dI/dt) _c =-5.3A/ms T _j =150°C		MIN	1	5	15	20	V/ μ s

Static Characteristics

Symbol	Parameter	Value(MAX)	Unit	
V_{TM}	I _{TM} =17A tp= 380 μ s	T _j =25°C	1.55	V
I_{DRM} I_{RRM}	V _D =V _{DRM} , V _R =V _{RRM}	T _j =25°C	5	μ A
		T _j =150°C	2	mA

Thermal Resistances :

Symbol	Parameter	Value	Unit	
R_{th(j-c)}	Junction to case for AC	TO-220A(Ins) (TC=100°C)	2.3	°C/W
		TO-220B(TC=113°C)	1.4	
		TO-220F(Ins) (TC=95°C)	2.5	
		TO-263(TC=118)°C	0.97	

FIG.1: Maximum power dissipation versus RMS on-state current

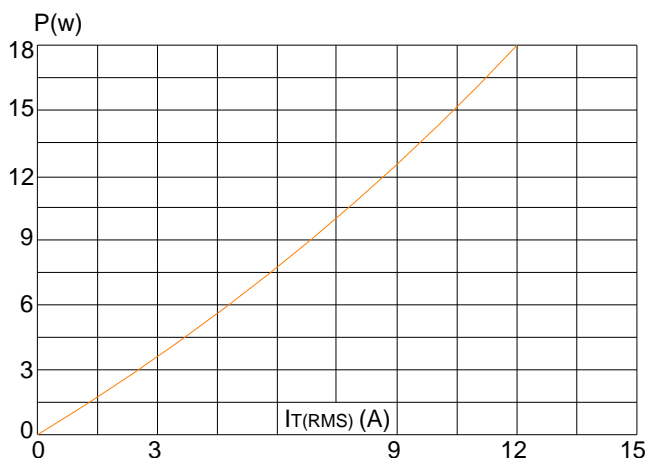

FIG.3: Surge peak on-state current versus number of cycles

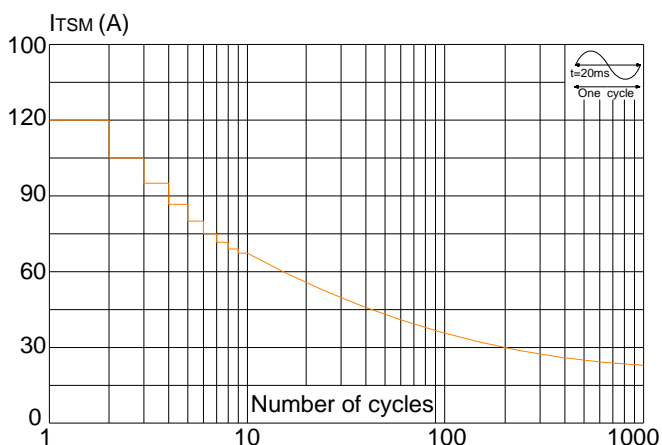

FIG.5: Non-repetitive surge peak on-state current for a sinusoidal pulse with width $t_p < 20\text{ms}$, and corresponding value of I^2t ($di/dt < 50\text{A}/\mu\text{s}$)

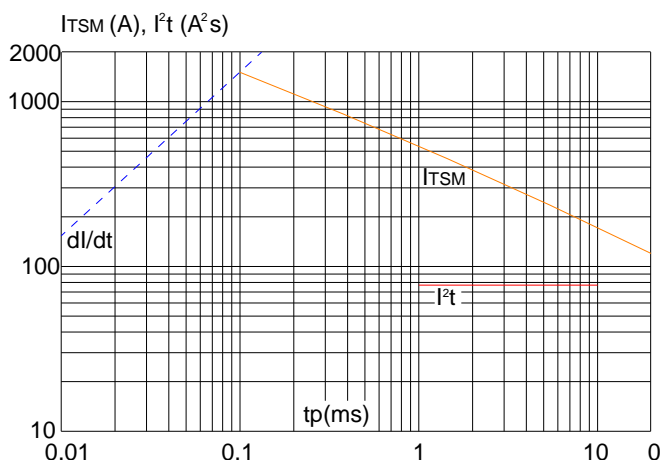

FIG.2: RMS on-state current versus case temperature

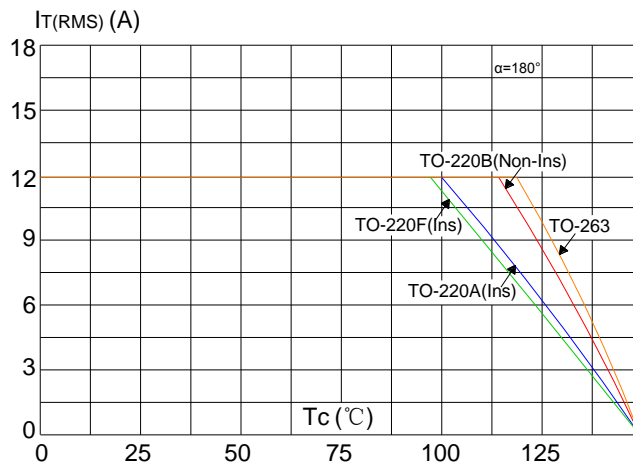

FIG.4: On-state characteristics (maximum values)

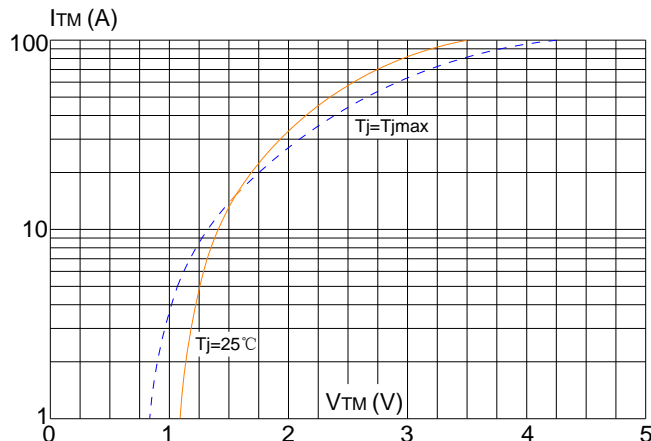
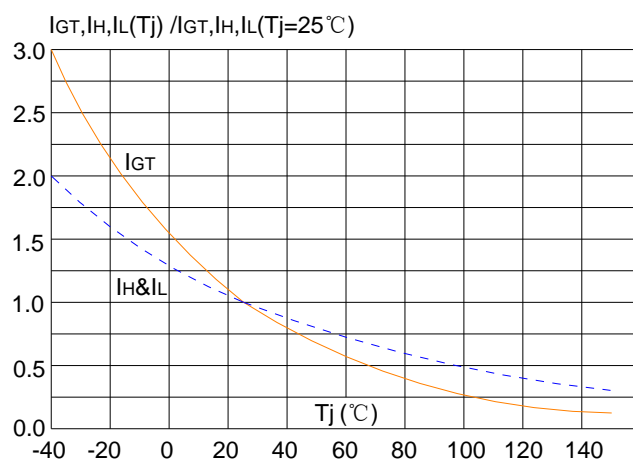
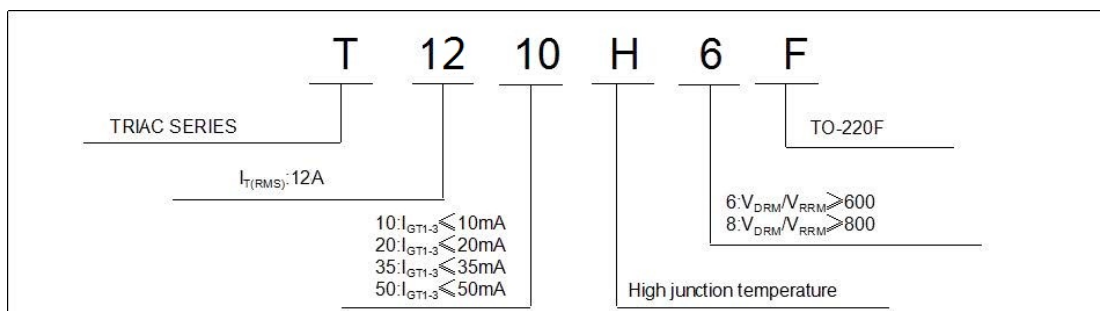

FIG.6: Relative variations of gate trigger current, holding current and latching current versus junction temperature



Ordering Information:



Package Mechanical Data :

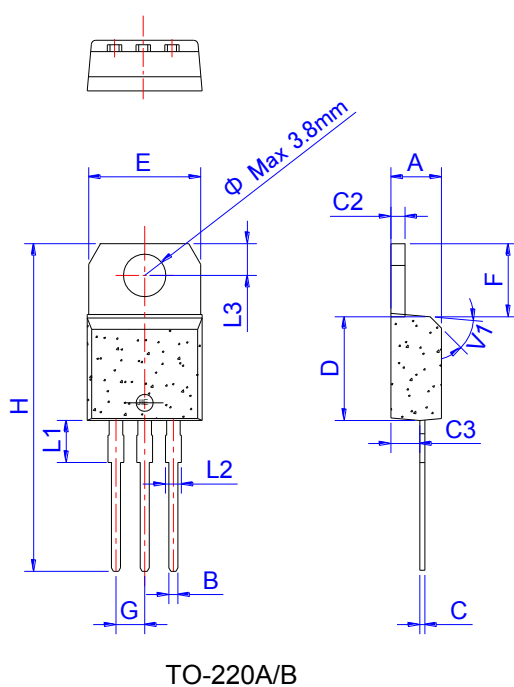

Ref.	Dimensions					
	Millimeters			Inches		
	Min.	Typ.	Max.	Min.	Typ.	Max.
A	4.40		4.60	0.173		0.181
B	0.61		0.88	0.024		0.035
C	0.46		0.70	0.018		0.028
C2	1.21		1.32	0.048		0.052
C3	2.40		2.72	0.094		0.107
D	8.60		9.70	0.339		0.382
E	9.60		10.4	0.378		0.409
F	6.20		6.60	0.244		0.260
G		2.54			0.1	
H	28.0		29.8	1.102		1.173
L1		3.75			0.148	
L2	1.14		1.70	0.045		0.067
L3	2.65		2.95	0.104		0.116
V1		45°			45°	

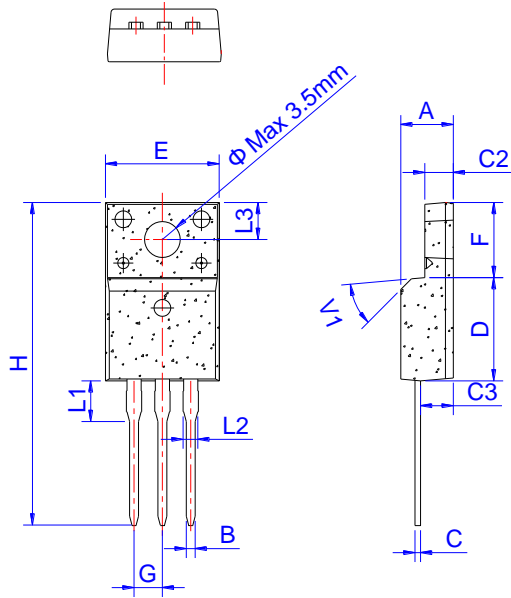

TO-220F Ins

Ref.	Dimensions					
	Millimeters			Inches		
	Min.	Typ.	Max.	Min.	Typ.	Max.
A	4.40		4.80	0.173		0.189
B	0.74	0.80	0.83	0.029	0.031	0.033
C	0.48		0.75	0.019		0.030
C2	2.40		2.70	0.094		0.106
C3	2.60		3.00	0.102		0.118
D	8.80		9.30	0.346		0.366
E	9.70		10.3	0.382		0.406
F	6.40		7.00	0.252		0.276
G		2.54			0.1	
H	28.0		29.8	1.102		1.173
L1		3.63			0.143	
L2	1.14		1.70	0.045		0.067
L3		3.30			0.130	
V1		45°			45°	

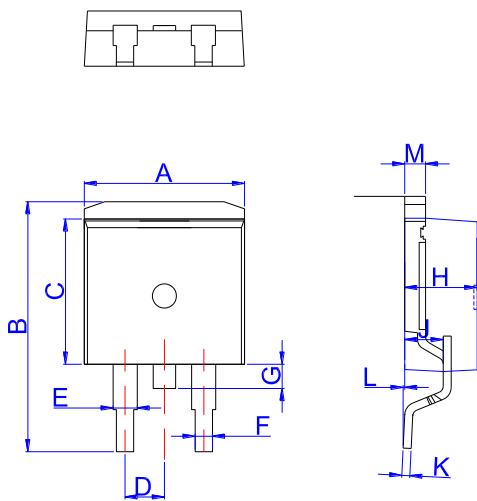

TO-263

Ref.	Dimensions					
	Millimeters			Inches		
	Min.	Typ.	Max.	Min.	Typ.	Max.
A	9.90		10.20	0.390		0.402
B	14.70		15.80	0.579		0.622
C	9.4		9.6	0.37		0.378
D		2.54			0.100	
E	1.20		1.40	0.047		0.055
F	0.75		0.85	0.029		0.033
G			1.75			0.069
H	4.40		4.70	0.173		0.185
J	2.30		2.70	0.091		0.106
K	0.38		0.55	0.015		0.022
L	0	0.10	0.25	0	0.004	0.010
M	1.25		1.35	0.049		0.053